



Furse copperbond earth rods probably offer to the installer the best and most economical earth rods available. They are made by molecularly bonding 99.9% pure electrolytic copper onto a low carbon steel core. **Furse rods are not of the sheathed type.** They are highly resistant to corrosion, and because the steel used has a very high tensile strength, they can be driven by power hammers to great depths.

The counter-bored couplings are made from high copper content alloy, **commercial brass is not used.** This again ensures excellent corrosion resistance and high strength.

Diameter of rod

One common misconception is that the diameter of the rod has a drastic effect on lowering earth resistance. This is not true! As the graph shows, you only lower the resistance value by 9.5 per cent by doubling the diameter of the rod (which means increasing the weight and the cost of the rod by approximately 400 per cent!)

Thus the rationale is: Use the most economical rod that soil conditions will allow you to drive. This is one of the ways to ensure that you don't waste money on over-dimensioned rods.

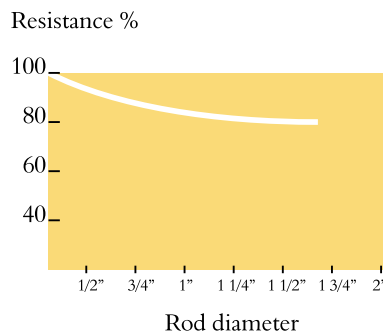

Effect of electrode diameter on resistance.

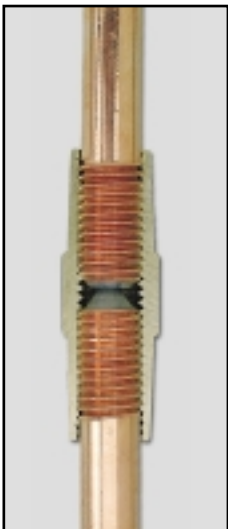

Thread and shank diameters

Confusion often arises between thread and shank diameters for threaded rods.

The thread rolling process, used by quality rod manufacturers, raises the surface of the rod so that thread diameter (B) is greater than shank diameter (A) (see drawing).

All threads are Unified National Coarse (UNC-2A).

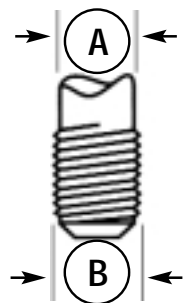

Unthreaded copperbond earth rods

Diameter	Length	Weight each	Part no.
9.0mm	1200mm	0.62kg	RB005
12.7mm	1200mm	1.18kg	RB103
12.7mm	1500mm	1.55kg	RB107
12.7mm	1800mm	1.76kg	RB116
12.7mm	2400mm	2.36kg	RB126
14.2mm	1200mm	1.53kg	RB203
14.2mm	1500mm	1.88kg	RB213
14.2mm	1800mm	2.29kg	RB216
14.2mm	2000mm	2.51kg	RB217
14.2mm	2100mm	2.68kg	RB223
14.2mm	2400mm	3.00kg	RB226
14.2mm	3000mm	3.79kg	RB236
17.2mm	1200mm	2.19kg	RB306
17.2mm	1500mm	2.73kg	RB313
17.2mm	1800mm	3.27kg	RB316
17.2mm	2000mm	3.64kg	RB317
17.2mm	2100mm	3.83kg	RB323
17.2mm	2400mm	4.35kg	RB326
17.2mm	3000mm	5.44kg	RB336

Fittings

Type	Weight each	Part no.
12.7mm Coupling	0.09kg	CG177
14.2mm Coupling	0.08kg	CG277
17.2mm Coupling	0.13kg	CG377
12.7 Driving head	0.25kg	ST107
14.2 Driving head	0.22kg	ST207
17.2 Driving head	0.27kg	ST307

BS 7430, BS 6651, UL467

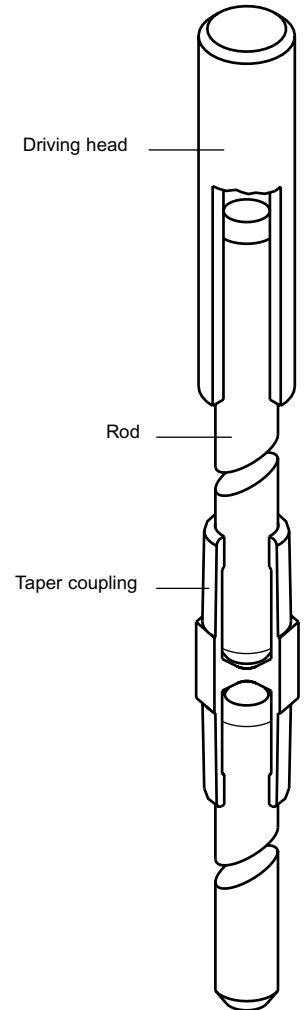

Threaded copperbond earth rods

Nominal diameter	Length	Thread diameter 'B'	Shank diameter 'A'	Weight each	Part no.
1/2"	1200mm	9/16"	12.7mm	1.18kg	RB105
1/2"	1500mm	9/16"	12.7mm	1.55kg	RB110
1/2"	1800mm	9/16"	12.7mm	1.76kg	RB115
1/2"	2400mm	9/16"	12.7mm	2.36kg	RB125
5/8"	1200mm	5/8"	14.2mm	1.53kg	RB205-FU
5/8"	1500mm	5/8"	14.2mm	1.88kg	RB210
5/8"	1800mm	5/8"	14.2mm	2.29kg	RB215
5/8"	2100mm	5/8"	14.2mm	2.51kg	RB220-FU
5/8"	2400mm	5/8"	14.2mm	3.00kg	RB225
5/8"	3000mm	5/8"	14.2mm	3.79kg	RB235
3/4"	1200mm	3/4"	17.2mm	2.19kg	RB305
3/4"	1500mm	3/4"	17.2mm	2.73kg	RB310
3/4"	1800mm	3/4"	17.2mm	3.27kg	RB315
3/4"	2400mm	3/4"	17.2mm	4.35kg	RB325
3/4"	3000mm	3/4"	17.2mm	5.44kg	RB335

Fittings

Type	Weight each	Part no.
1/2" Coupling	0.09kg	CG170
5/8" Coupling	0.08kg	CG270
3/4" Coupling	0.13kg	CG370
1/2" Driving stud	0.05kg	ST100
5/8" Driving stud	0.08kg	ST200
3/4" Driving stud	0.12kg	ST300

BS 7430, BS 6651, UL467

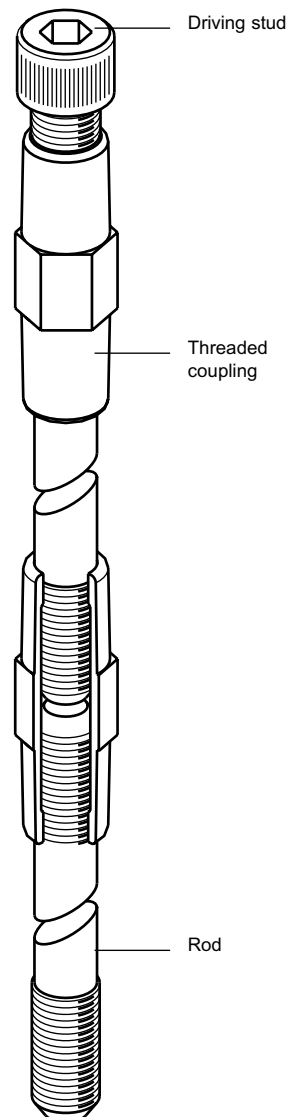

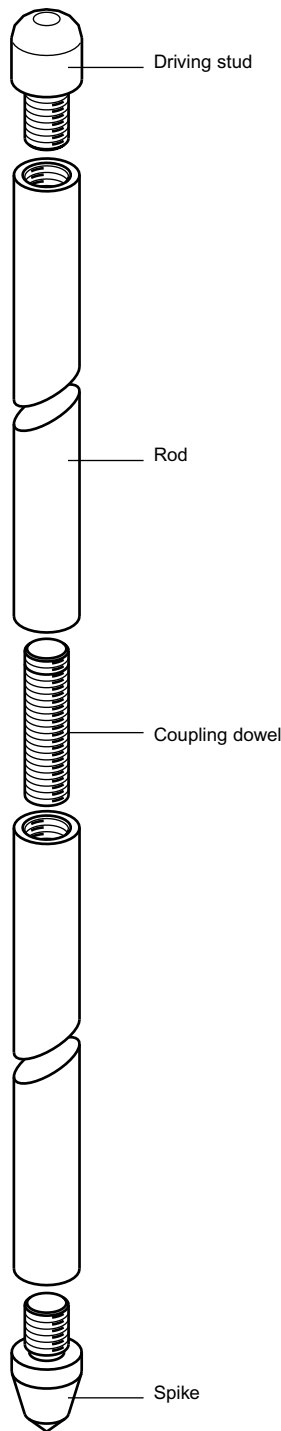

Solid copper rod

Furse solid copper earth rods offer greater resistance to corrosion. They are ideally used in applications where soil conditions are very aggressive, such as soils with high salt content. Connections to the rods can be by mechanical clamps, compression or by Furse’s own “Furseweld” exothermic welding system.

Rod details

Diameter	Length	Weight each	Part no.
15mm	1200mm	1.88kg	RC010
20mm	1200mm	3.34kg	RC015

Fittings

Type	Weight each	Part no.
15mm Driving stud	0.02kg	ST010
20mm Driving stud	0.05kg	ST015
Coupling dowel for both sizes of above rods	0.02kg	CG013
15mm Spike	0.02kg	SP010
20mm Spike	0.04kg	SP015

BS 7430, BS 6651

Stainless steel rod

Stainless steel rods are used to overcome many of the problems caused by galvanic corrosion which can take place between dissimilar metals buried in close proximity. Furse stainless steel earth rods are highly resistant to corrosion.

Connections to the rods can be by mechanical clamps, compression or by Furse’s own “Furseweld” exothermic welding system.

Rod details

Diameter	Length	Weight each	Part no.
16mm	1200mm	1.87kg	RS005

Fittings

Type	Weight each	Part no.
15mm Driving stud	0.02kg	ST010
Stainless steel coupling dowel	0.02kg	CG005
15mm Spike	0.02kg	SP010

BS 7430, BS 6651