

# ***GasAlertMicro 5***

O<sub>2</sub>, CO, H<sub>2</sub>S, PH<sub>3</sub>, SO<sub>2</sub>, Cl<sub>2</sub>, NH<sub>3</sub>, NO<sub>2</sub>, HCN, ClO<sub>2</sub>, O<sub>3</sub>, VOC, and Combustibles

1, 2, 3, 4, and 5 Gas Detectors

Quick Reference Guide

"INNOVATORS IN GAS DETECTION"

**BWF**  
Technologies

## Limited Warranty & Limitation of Liability

BW Technologies Ltd. (BW) warrants this product to be free from defects in material and workmanship under normal use and service for a period of two years, beginning on the date of shipment to the buyer. This warranty extends only to the sale of new and unused products to the original buyer. BW's warranty obligation is limited, at BW's option, to refund of the purchase price, repair, or replacement of a defective product that is returned to a BW authorized service center within the warranty period. In no event shall BW's liability hereunder exceed the purchase price actually paid by the buyer for the Product. This warranty does not include:

- a) fuses, disposable batteries or the routine replacement of parts due to the normal wear and tear of the product arising from use;
- b) any product which in BW's opinion, has been misused, altered, neglected or damaged by accident or abnormal conditions of operation, handling or use;
- c) any damage or defects attributable to repair of the product by any person other than an authorized dealer, or the installation of unapproved parts on the product; or

The obligations set forth in this warranty are conditional on:

- a) proper storage, installation, calibration, use, maintenance and compliance with the product manual instructions and any other applicable recommendations of BW;
- b) the buyer promptly notifying BW of any defect and, if required, promptly making the product available for correction. No goods shall be returned to BW until receipt by the buyer of shipping instructions from BW; and
- c) the right of BW to require that the buyer provide proof of purchase such as the original invoice, bill of sale or packing slip to establish that the product is within the warranty period.

THE BUYER AGREES THAT THIS WARRANTY IS THE BUYER'S SOLE AND EXCLUSIVE REMEDY AND IS IN LIEU OF ALL OTHER WARRANTIES, EXPRESS OR IMPLIED, INCLUDING BUT NOT LIMITED TO ANY IMPLIED WARRANTY OF MERCHANTABILITY OR FITNESS FOR A PARTICULAR PURPOSE. BW SHALL NOT BE LIABLE FOR ANY SPECIAL, INDIRECT, INCIDENTAL OR CONSEQUENTIAL DAMAGES OR LOSSES, INCLUDING LOSS OF DATA, WHETHER ARISING FROM BREACH OF WARRANTY OR BASED ON CONTRACT, TORT OR RELIANCE OR ANY OTHER THEORY.

Since some countries or states do not allow limitation of the term of an implied warranty, or exclusion or limitation of incidental or consequential damages, the limitations and exclusions of this warranty may not apply to every buyer. If any provision of this warranty is held invalid or unenforceable by a court of competent jurisdiction, such holding will not affect the validity or enforceability of any other provision.

### Contacting BW Technologies

1-888-749-8878 USA

+44 (0) 1869 233004 Europe

+852-2974-1783 China

+61-438-887-232 Australia

1-800-663-4164 Canada

+971-4-8871766 Middle East

+65-9737-2005 South East Asia

+1-403-248-9226 other countries

Visit BW Technologies' web site at: [www.gasmonitors.com](http://www.gasmonitors.com)

## Introduction

This quick reference guide provides basic information for the GasAlertMicro 5. Refer to the user manual on the accompanying CD-ROM for complete operating instructions. The GasAlertMicro 5 gas detector ("the detector") warns of hazardous gas at levels above user-selectable alarm setpoints.

The detector is a personal safety device. It is your responsibility to respond properly to the alarm.

## Safety Information - Read First

Use the detector only as specified in this guide, otherwise the protection provided by the detector may be impaired.

Read the following **Cautions** before using the detector.

### Cautions

- ⇒ **Warning:** Substitution of components may impair Intrinsic Safety.
- ⇒ **Caution:** For safety reasons, this equipment must be operated and serviced by qualified personnel only. Read and understand the user manual completely before operating or servicing.
- ⇒ Calibrate the detector before first-time use and then on a regular schedule, depending on use and sensor exposure to poisons and contaminants. BW recommends at least once every 180 days (6 months).
- ⇒ It is recommended that the combustible sensor be checked with a known concentration of calibration gas after any known exposure to catalyst contaminants/poisons (sulfur compounds, silicon vapors, halogenated compounds, etc.).

- ⇒ BW recommends to “bump test” the sensors, before each day’s use, to confirm their ability to respond to gas by exposing the detector to a gas concentration that exceeds the high alarm setpoints. Manually verify that the audible and visual alarms are activated. Calibrate if the readings are not within the specified limits.
- ⇒ Only the combustible gas detection portion of this instrument has been assessed for performance by CSA International.
- ⇒ The combustible sensor is factory calibrated to 50% LEL Methane. If monitoring a different combustible gas in the % LEL range, calibrate the sensor using the appropriate gas.
- ⇒ Caution: High off-scale readings may indicate an explosive concentration.
- ⇒ Protect the combustible sensor from exposure to lead compounds, silicones, and chlorinated hydrocarbons. Although certain organic vapors (such as leaded gasoline and halogenated hydrocarbons) may temporarily inhibit sensor performance, in most cases, the sensor will recover after calibration.
- ⇒ For use only in potentially explosive atmospheres where Oxygen concentrations do not exceed 20.9% (v/v).
- ⇒ Any rapid up-scaling reading followed by a

declining or erratic reading may indicate a gas concentration beyond upper scale limit, which may be hazardous.

- ⇒ Extended exposure of the GasAlertMicro 5 to certain concentrations of combustible gases and air may stress a detector element, which can seriously affect its performance. If an alarm occurs due to high concentration of combustible gases, recalibration should be performed, or if needed, the sensor replaced.
- ⇒ Electromagnetic interference may cause incorrect operation under certain circumstances.

**Parts of the GasAlertMicro 5**

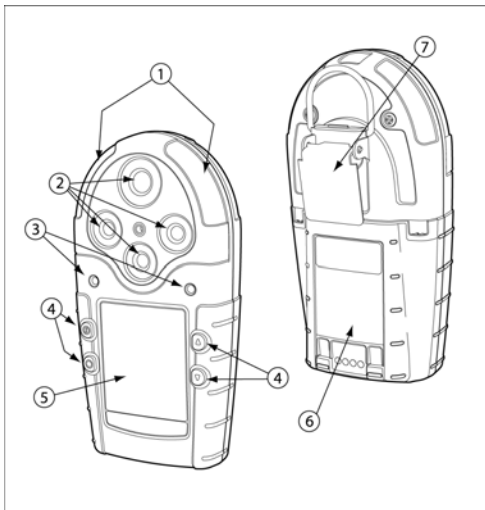





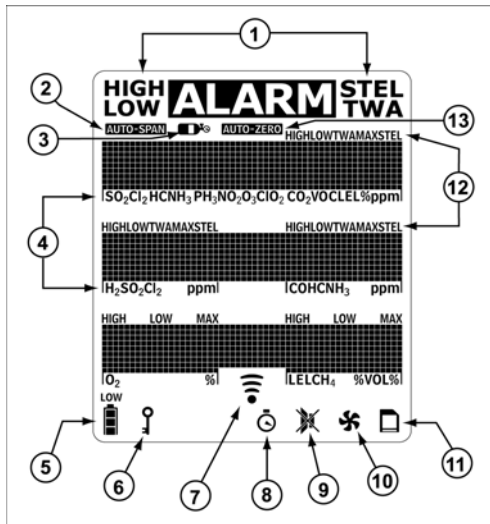











Item	Function
①	Visual alarm bars
②	Sensors
③	Audible alarm
④	Pushbuttons
⑤	Display
⑥	Battery pack
⑦	Alligator clip

**Display Elements**



Item	Function
①	Alarm condition
②	Automatically span sensor
③	Gas cylinder
④	Gas identifier bars
⑤	Battery life indicator
⑥	Pass code lock
⑦	Data transmission (future use)
⑧	Clock
⑨	Stealth mode
⑩	Optional pump indicator
⑪	Optional datalogger card indicator
⑫	Alarm condition (low, high TWA, STEL, or multi-gas) or view TWA, STEL, and maximum gas exposures
⑬	Automatically zero sensor





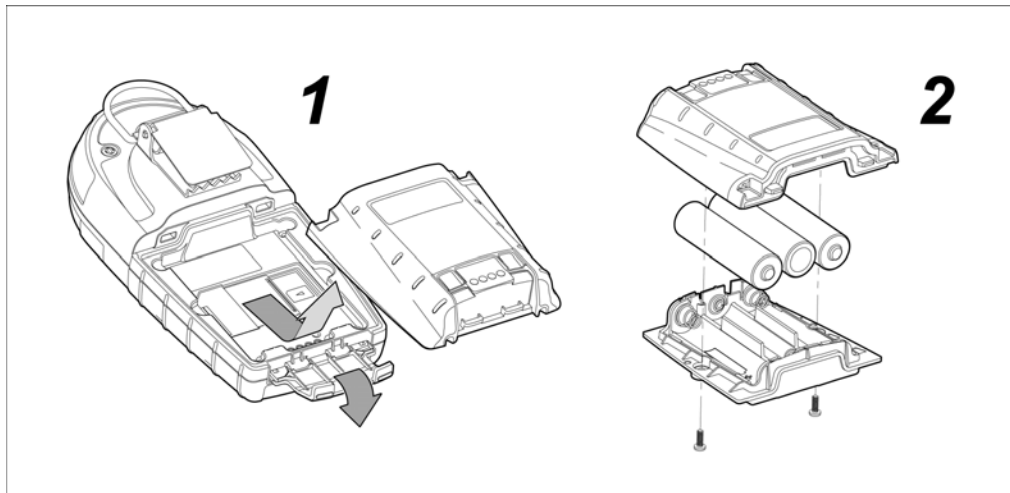







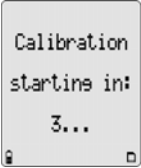





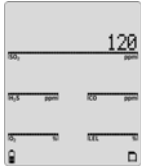

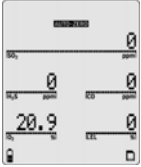
## Pushbuttons

Pushbutton	Description
	<ul style="list-style-type: none"> <li>● To turn on the detector, press .</li> <li>● To turn off the detector, press  and hold until countdown is complete.</li> </ul>
	<ul style="list-style-type: none"> <li>● To increment the displayed value, press .</li> <li>● To enter the user options menu, press  and  simultaneously and hold until countdown is complete.</li> <li>● To clear the TWA, STEL, and maximum gas exposure readings, press  and  simultaneously and hold until countdown is complete.</li> </ul>
	<ul style="list-style-type: none"> <li>● To decrement the displayed value, press .</li> <li>● To initiate calibration and setting alarm setpoints, press  and  simultaneously and hold until countdown is complete.</li> </ul>
	<ul style="list-style-type: none"> <li>● To view the TWA, STEL, and maximum (MAX) hold readings, press .</li> <li>● To acknowledge latched alarms, press .</li> </ul>

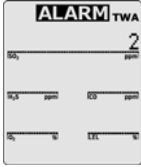
**Install the Batteries**

1. Open the latch on the bottom of the detector and remove the battery pack by lifting up the end of the pack.
2. Remove the two screws on the battery pack, open the pack, and install the three alkaline batteries. Then replace the cover.
3. Insert the battery pack back into place and secure the latch.

## Calibration

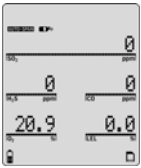
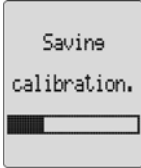
Procedure	Display	Procedure	Display
<p>1. In a clean atmosphere, press and hold  and  simultaneously (as the detector beeps and flashes to the corresponding countdown) to enter calibration. The detector then reads <b>Starting calibration.</b></p>		<p>4. Press  or  to change the next calibration due date and press  to accept this value. (If a sensor failed or did not span, you cannot change the calibration due date for that sensor.) The display then advises to press  to set or  to skip the alarm setpoints.</p>	
<p>2. <b>AUTO-ZERO</b> flashes while the detector zeroes all of the sensors and calibrates the Oxygen sensor. If a sensor failed to auto zero, it will bypass the span. Once auto zero is complete, the display directs you to either apply calibration gas to the detector, or press  to skip the span.</p>		<p>5. Press  or  to change the alarm setpoint and press  to save the displayed value and proceed to the next setpoint. Set the remaining setpoints. The detector beeps four times at the end of the alarm setpoint stage.</p>	
<p>3.  flashes when you connect the calibration bottle and apply gas at a flow rate of 250-500 ml/min. If the span is successful, press  to apply a new cal-gas for another sensor, or  to end the span. Once all sensors have spanned, the display advises to press  to set or  to skip the calibration due dates.</p>		<p>6. <b>Saving calibration</b> is displayed to indicate that calibration is complete.</p>	

**Attaching the Calibration Bottle**





## Alarms

The following table lists the numerous alarms of the detector.

Alarm	Display	Alarm	Display
<p><b>Low Alarm:</b></p> <ul style="list-style-type: none"> <li>• Fast modulating tone</li> <li>• Slow flash</li> <li>• <b>ALARM</b> and target gas bar flash</li> <li>• Vibrator alarm activates</li> </ul>		<p><b>TWA Alarm:</b></p> <ul style="list-style-type: none"> <li>• Fast modulating tone</li> <li>• Slow flash</li> <li>• <b>ALARM</b> and target gas bar flash</li> <li>• Vibrator alarm activates</li> </ul>	
<p><b>High Alarm:</b></p> <ul style="list-style-type: none"> <li>• Constant tone</li> <li>• Fast flash</li> <li>• <b>ALARM</b> and target gas bar flash</li> <li>• Vibrator alarm activates</li> </ul>		<p><b>STEL Alarm:</b></p> <ul style="list-style-type: none"> <li>• Constant tone</li> <li>• Fast flash</li> <li>• <b>ALARM</b> and target gas bar flash</li> <li>• Vibrator alarm activates</li> </ul>	

Alarm	Display	Alarm	Display
<b>Multi-Gas Alarm:</b> <ul style="list-style-type: none"> <li>Alternating low and high alarm tone and flash</li> <li><b>ALARM</b> and target gas bars flash</li> <li>Vibrator alarm activates</li> </ul>		<b>Over Range Alarm: (Over Level Exposure)</b> <ul style="list-style-type: none"> <li>Fast modulating tone and flash</li> <li><b>ALARM</b> and target gas bar flash</li> <li>Vibrator alarm activates</li> </ul>	
<b>Sensor Alarm:</b> <ul style="list-style-type: none"> <li>Slow modulating tone and flash</li> <li><b>ALARM</b> and gas bar(s) flash</li> <li>Vibrator alarm activates</li> </ul>		<b>Automatic Shutdown Alarm:</b> <ul style="list-style-type: none"> <li>8 beeps and flashes</li> <li>Vibrator alarm temporarily activates</li> </ul>	
<b>Low Battery Alarm:</b> (Confidence beep disabled) <ul style="list-style-type: none"> <li>1 beep and 1 flash every 10 seconds</li> <li> flashes</li> </ul>		<b>Normal Shutdown:</b> <ul style="list-style-type: none"> <li>3 beeps and flashes</li> <li>Vibrator alarm temporarily activates</li> </ul>	

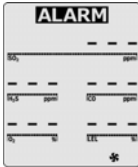
Alarm	Display	Alarm	Display
<p><b>Confidence Beep:</b></p> <ul style="list-style-type: none"> <li>2 fast beeps every 15 seconds</li> </ul>		<p><b>Pump Alarm:</b></p> <ul style="list-style-type: none"> <li>Slow modulating tone and flash</li> <li><b>ALARM</b> and  flash</li> </ul>	

## **User Options Menu**

To access the user options menu press and hold ▲ and ▼ until the detector completes the countdown.

To scroll through the options, press ▼ or ▲. Press ○ to select the option. The following are the available user options:

1. **Exit:** Exits the user options menu.
2. **Language:** Enables the display's language in the user's choice of English, French, Spanish, German, or Portuguese.
3. **Options:**
  - **Backlight:** Enables the backlight in low-light conditions;
  - **Confibeep:** Enables/disables the confidence beep;
  - **Force Cal:** Forces the detector into mandatory calibration if a sensor is overdue for calibration upon startup;

- **Due-lock:** Upon startup, it prevents the user from operating a detector that is overdue for calibration by requesting a pass code;
- **Latch:** This option allows an alarm to remain active until the user acknowledges the alarm;
- **Passcode:** Prevents unauthorized personnel from having access to the user options menu, calibration function, and alarm setpoint adjust function.
- **Safe:** Enables the display to read **Safe** if the detector does not enter an alarm;
- **Stealth:** Enables vibrator signaling only.

### 4. **Sensors:**

- **Sens on:** Enables/disables the sensor (the detector still operates if a sensor is disabled);
- **Span gas:** Changes the span gas concentration for each sensor;
- **STEL period:** Changes the short-term exposure limit (only applicable to toxic sensors);

- **TWA method:** Choose either the OSHA or ACGIH standard of calculating the time-weighted average;
  - **Correction:** Allows the user to adjust the instrument reading for a specific combustible gas (only applicable to LEL and PID sensors);
  - **Precision:** Sets the accuracy of the gas reading (if applicable);
  - **% vol CH<sub>4</sub>:** Shows the LEL reading in % vol. assuming a Methane environment;
  - **Auto-cal:** Automatic Oxygen calibration upon startup.
5. **Logger:** Allows the user to change the datalogging interval (between 5-120 seconds).
6. **Clock:** Allows the user to set the date and time for the detector.

## ***Maintenance***

To keep the detector in good operating condition, perform the following basic maintenance as required:

- Calibrate, bump check, and inspect the detector at regular intervals.
- Keep an operations log of all maintenance, bump checks, calibrations, and alarm events.
- Clean the exterior with a soft damp cloth. Do not use solvents, soaps, or polishes.
- Do not immerse the detector in liquids.

### ***Photoionization Detector (PID) Sensor***

#### *Clean the Lamp*

The PID lamp needs to be cleaned (with a cleaning kit) in the following situations:

- When the PID reading creeps upward after the sensor is zeroed;
- When any movement of the detector changes the PID reading.

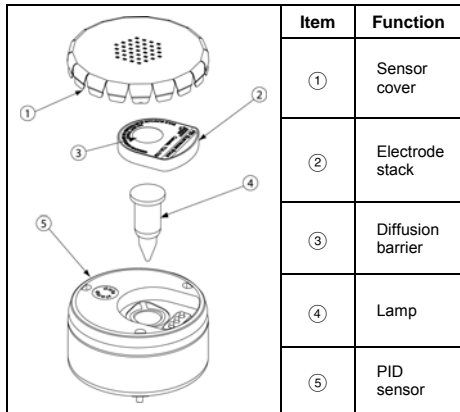
**Parts of the PID Sensor****⚠ Caution****Never handle the lamp with your bare hands.**

1. Place finger covers on your fingers.
2. Take apart the sensor to remove the lamp.

3. Place some Methanol on the end of a cotton-tipped stick before using it to clean the lamp.
4. Once clean, reassemble the sensor.

**Replace the Electrode Stack**

Replace the electrode stack when it is contaminated.

1. Remove the sensor cover.
2. Remove the old electrode stack.
3. Install the new electrode stack in its place.

*Note**Ensure your fingers do not make contact with the diffusion barrier and the electrodes on the underside of the stack.*

4. Replace the sensor cover.

### *Replace the Lamp*

Replace the lamp when it falls below the acceptable level.

1. Remove the old lamp from the PID.
2. Ensure finger covers are on before inserting the new lamp into the PID shell.
3. Reassemble the sensor.

### **Specifications**

**Instrument dimensions:** 14.5 x 7.4 x 3.8 cm  
(5.7 x 2.9 x 1.5 in.)

**Weight:** 300 g (10.6 oz.)

#### **Operating temperature:**

VOC: -10°C to +40°C (14°F to +104°F)

Other gases: -20°C to +50°C (-4°F to +122°F)

**Storage temperature:** -20°C to +50°C (-4°F to +122°F)

#### **Operating humidity:**

O<sub>2</sub>: 0% to 99% relative humidity (non-condensing)

VOC: 0% to 95% relative humidity (non-condensing)

Cl<sub>2</sub>: 10% to 95% relative humidity (non-condensing)

HCN, ClO<sub>2</sub>: 15% to 95% relative humidity (non-condensing)

Other gases: 15% to 90% relative humidity (non-condensing)

**Operating pressure:** 95 to 110 kPa

**Alarm setpoints:** May vary by region and are user-settable

#### **Detection range:**

O<sub>2</sub>: 0 – 30.0% vol. (0.1% vol. increments)

CO: 0 – 999 ppm (1 ppm increments)

H<sub>2</sub>S: 0 – 100 ppm (1 ppm increments)

PH<sub>3</sub>: 0 – 5.0 ppm (0.1 ppm increments)

SO<sub>2</sub>: 0 – 100 ppm (1 ppm increments)

Cl<sub>2</sub>: 0 – 50.0 ppm (0.1 ppm increments)

NH<sub>3</sub>: 0 – 100 ppm (1 ppm increments)

NO<sub>2</sub>: 0 – 99.9 ppm (0.1 ppm increments)

HCN: 0 – 30.0 ppm (0.1 ppm increments)

ClO<sub>2</sub>: 0 – 1.00 ppm (0.01 ppm increments)

O<sub>3</sub>: 0 – 1.00 ppm (0.01 ppm increments)

VOC: 0-1000 (5.0 ppm increments)

#### **Sensor type:**

H<sub>2</sub>S/CO: Twin plug-in electrochemical cell

Combustibles: Plug-in catalytic bead

VOC: Photoionization detector (PID)

Other gases: Single plug-in electrochemical cell

**O<sub>2</sub> measuring principle:** Capillary controlled concentration sensor

**Alarm conditions:** TWA alarm, STEL alarm, low alarm, high alarm, multi-gas alarm, sensor alarm, pump alarm, low battery alarm, confidence beep, automatic shutdown alarm

**Audible alarm:** 95 dB at 1 ft (0.3 m) variable pulsed dual beepers

**Visual alarm:** Dual red light-emitting diodes (LED)

**Display:** Alphanumeric liquid crystal display (LCD)

## GasAlertMicro 5

### Quick Reference Guide

---

**Backlight:** Automatically activates whenever there is insufficient light to view the display (if enabled) and during alarm conditions

**Self-test:** Initiated at activation

**Calibration:** Automatic zero and automatic span

**Oxygen sensor:** Automatic span on activation (selectable)

**User field options:** Confidence beep, latching low and high alarms, pass code protection, enable/display Safe display mode combustible sensor measurement, sensor disable, set calibration due date, TWA and STEL, stealth mode, language selection, enable/disable automatic Oxygen calibration, set span concentration values, set STEL calculation period, set TWA method, enable/disable automatic backlight, adjust clock calendar, and set logging rate (datalogger models only).

#### **Battery operating time:**

Given that detector is operating with an LEL and PID sensor and the optional pump:

3 alkaline cells: 8-10 hours

1 rechargeable NiMH pack: 14-16 hours

#### **Approved batteries:**

##### **North America**

Approved batteries for product (standards EN50020, UL913, C22.2 No. 157)

##### **Alkaline:**

Duracell MN1500

Energizer E91

Duracell MN1500

Energizer E91

##### **Temperature Code**

-20°C ≤ to ≤ 50°C (139.8°C)

-20°C ≤ to ≤ 50°C (163°C)

-20°C ≤ to ≤ 40°C (129.8°C)

-20°C ≤ to ≤ 40°C (153°C)

##### **NiMH rechargeable:**

Sanyo HR-3U

**Battery charger:** GasAlertMicro 5 battery charger

**First-time charge:** 4 hours per battery pack

**Normal charge:** 3-4 hours per battery pack

**Approvals:** Intrinsic safety certifications in progress





**[www.keison.co.uk](http://www.keison.co.uk)**

**[sales@keison.co.uk](mailto:sales@keison.co.uk)**

**Tel: +44 1245 600560**

**Fax: +44 1245 600030**

