



# Installation, Operation & Maintenance Instructions

Acid Gas Determinator Furnace

AGD 12/4

This manual is for the guidance of operators of the above Carbolite products and should be read before the furnace is connected to the electricity supply.

---

## CONTENTS

Section		page
1.0	Symbols & Warnings	2
2.0	Installation	3
3.0	Operation	5
4.0	Maintenance	7
5.0	Repairs & Replacements	8
6.0	Fault Analysis	11
7.0	Circuit Diagrams	13
8.0	Fuses & Power Settings	15
9.0	Specifications	16

---

**Manuals are supplied separately for the furnace controller (and overtemperature controller when fitted).**

Please read the controller manuals before operating the furnace.



**1.0 SYMBOLS & WARNINGS**

**1.1 Switches and Lights**



Supply Light: when the furnace is connected to the electrical supply the light in the adjacent switch glows

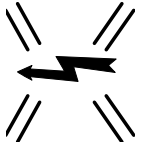

Heat Switch: the switch disconnects power to the heating elements; unless this switch is off there is a danger of electric shock when inserting objects into the furnace

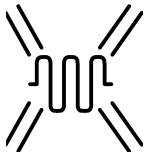

Heat Light: the adjacent light glows or flashes to indicate that power is being supplied to the elements

**1.2 Warning Symbols**

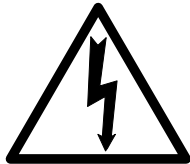

DANGER of electrical shock– read any warning printed by this symbol.



DANGER – hot surface. Read any warning printed by this symbol.  
WARNING: all surfaces of a furnace may be hot.



DANGER – read any warning printed by this symbol.

## **2.0 INSTALLATION**

### **2.1 Unpacking & Handling**

When unpacking or moving the furnace always lift it by its base. Never lift it by its work tubes or the surrounding insulation. Ideally use two people to carry the furnace.

Remove any packing material from inside the furnace before use.

### **2.2 Siting**

Place the furnace in a well ventilated room, away from other sources of heat, and on a surface which is resistant to accidental spillage of hot materials. Do not mount the furnace on an inflammable surface.

Ensure that there is free space around the furnace. Do not obstruct any of the vents in the control section: they are needed to keep the controls cool.

Ensure that the furnace is placed in such a way that it can be quickly switched off or disconnected from the electrical supply - see below.

### **2.3 Setting Up**

If the furnace is supplied with its four ceramic work tubes separately packed, then carefully slide these through the furnace body. It may help to support each tube on a pole such as a broom handle while fitting it.

If quartz (silica) inner tubes are supplied, fit them. Connect any components necessary for the purpose for which the furnace is to be used.

**2.4 Electrical Connections**

*Connection by a qualified electrician is recommended.*

The furnace may be ordered for single phase A.C. supply, which may be Live to Neutral non-reversible, Live to Neutral reversible or Live to Live; it may also be ordered for three phase use, either 3-phase + neutral or 3-phase delta.

Check the furnace rating label before connection. The supply voltage should agree with the voltage on the label, and the supply capacity should be sufficient for the amperage on the label.

The supply should be fused at the next size equal to or higher than the amperage on the label. The fuse ratings are also given in section 8.1 of this manual. If a supply cable is present there are internal supply fuses, in which case customer fusing is preferred but not essential.

Furnace with supply cable: either wire directly to an isolator or fitted with a line plug.

Furnace without supply cable: a permanent connection to a fused and isolated supply should be made to the internal terminals after temporary removal of the furnace back panel.

Connection by line plug: the plug should be within reach of the operator, and should be quickly removable.

Connection to isolating switch: this should operate on both conductors (single phase) or on all live conductors (three phase), and should be within reach of the operator.

The supply **MUST** incorporate an earth (ground).

1-phase CONNECTION DETAILS

Supply	Terminal label	Cable colour	supply type	
			Live-Neutral	Reversible or Live-Live
<b>1-phase</b>	L	Brown	To live	to either power conductor
	N	Blue	To neutral	to the other power conductor
	PE	Green/Yellow	To earth (ground)	to earth (ground)

3-phase CONNECTION DETAILS

Supply	Terminal label	Cable colour	
<b>3-phase</b>	L1	Black	to phase 1
	L2	Black	to phase 2
	L3	Black	to phase 3
	N	Light Blue	to neutral <i>except delta</i>
	PE	Green/Yellow	to earth (ground)

DO NOT connect a furnace ordered for three phase use to a single phase supply or to the wrong type of three phase supply.

### 3.0 OPERATION

The instructions for operating the temperature controller are given in a separate manual.

If the furnace is fitted with a time switch, see also the supplementary manual MS03.

If cascade control is fitted, see the supplementary manual MS07.

#### 3.1 Operating Cycle

The furnace is fitted with a combined Supply light and Instrument switch. The light is on whenever the furnace is connected to the supply. The switch cuts off power to the control circuit. There is also a Heater switch which can be used to disconnect power to the elements.

Connect the furnace to the electrical supply. The Supply light should glow .

Operate the instrument switch to activate the temperature controller; the **O** position is *off*, the **I** position *on*. The controller becomes illuminated and goes through a short test cycle.

Set the temperature controller to the desired setpoint or program - see the controller manual.

*Overtemperature option only.* If the overtemperature controller has not yet been set as required, set it and activate it according to the instructions in the appropriate manual.

Switch on the Heater switch, located on the instrument panel. Unless a time switch is fitted and is off, the furnace starts to heat up. The Heat light(s) glow steadily at first and then flash as the furnace approaches the desired temperature or a program setpoint.

*Overtemperature option only.* If the overtemperature trip operates then an indicator in the overtemperature controller flashes, and the heating elements are isolated. Find and correct the cause before resetting the overtemperature controller according the instructions supplied.

To switch off power to the heating elements, use the Heater Switch. To switch the furnace off, use both the Heater switch and the Instrument switch. If the furnace is to be left off, isolate it from the electrical supply.

#### 3.2 General Operating Advice

Heating element life is shortened by use at temperatures close to maximum. Do not leave the furnace at high temperature when not required. The maximum temperature is shown on the furnace rating label and on the back page of this manual.

Switch off the Heater switch whenever loading or unloading the furnace - see the safety warning below.

A ceramic work tube may be cracked if workpieces are inserted too quickly or at temperatures below 900°C (when the tube is more brittle). Large pieces should also be heated slowly to ensure that large temperature differences do not arise.

Poor thermal contact should be encouraged between the workpiece and the tube; crucibles or boats should be of low thermal mass and should have feet to reduce the contact with the tube (fig. 4).

Avoid metal directly touching the work tube - see the safety warning below.

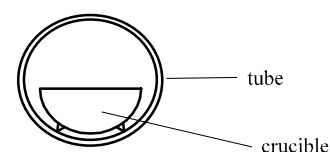

Fig 4  
avoidance of thermal contact

### 3.3 Operator Safety

The ceramic materials used in furnace manufacture become electrically conductive at high temperatures. There are partially exposed heating coils in the chamber which become accessible if the work tubes are removed. **DO NOT** use any conductive tools within the ceramic work tubes or chamber without isolating the elements.

The elements are isolated when the Heater switch is OFF. This switch cuts both sides of the circuit directly or via a contactor (a contactor is used in models where the rated current exceeds 16 Amps).

Avoid burns. Carbolite can supply tongs, face masks, and heat resistant gloves. Before you remove a hot object from the furnace make sure you have a safe place to put it down.

---

## **4.0 MAINTENANCE**

### **4.1 General Maintenance**

No routine maintenance is required. The outer surfaces may be cleaned with a damp cloth. Do not allow water to enter the interior of the case, tube or control box. Do not clean with organic solvents.

### **4.2 Calibration**

After prolonged use the controller and/or thermocouple could require recalibration. This would be important for processes which require accurate temperature readings or which use the furnace close to its maximum temperature. A quick check using an independent thermocouple and temperature indicator should be made from time to time to determine whether full calibration is required. These items can be supplied by Carbolite.

Depending on the controller, the controller manual may contain calibration instructions.

### **4.3 After Sales Service**

Carbolite's service division (Thermal Engineering Services) has a team of Service Engineers capable of repair, calibration and preventive maintenance of furnace and oven products at our customers' premises throughout the world. We also sell spares by mail order. A telephone call or fax often enables a fault to be diagnosed and the necessary spare part despatched.

Each furnace has its own record card at Carbolite. In all correspondence please quote the serial number, model type and voltage given on the rating label of the furnace. The serial number and model type are also given on the front of this booklet when supplied with a furnace.

To contact Thermal Engineering Services or Carbolite see the back page of this manual.

### **4.4 Recommended Spares Kits**

Carbolite can supply individual spares, or a kit of the items most likely to be required. Ordering a kit in advance can save time in the event of a breakdown. Each kit comprises one thermocouple, one solid state relay, and one heating element.

When ordering spares please quote the model details as requested above.

### **4.5 Power Adjustment**

The furnace control system incorporates electronic power limiting. The power limit parameter  $\square PH_i$  may be inaccessible to the operator.

Occasionally the power limit is set to zero to permit demonstration of the controls without the heating elements taking power. In this case the power limit is accessible to the operator, and can be reset to its original value.

For most voltages the design value of the power limit parameter is 100%. Check section 8.2 for details of any exceptions.

## 5.0 REPAIRS & REPLACEMENTS

### 5.1 Safety Warning – Disconnection from Supply

Always ensure that the furnace is disconnected from the supply before repair work is carried out.

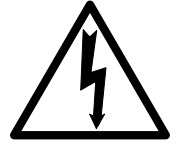

### 5.2 Safety Warning - Refractory Fibrous Insulation

This furnace contains refractory fibres in its thermal insulation. These materials may be in the form of fibre blanket or felt, vacuum formed board or shapes, mineral wool slab or loose fill fibre.



Normal use of the furnace does not result in any significant level of airborne dust from these materials, but much higher levels may be encountered during maintenance or repair.

Whilst there is no evidence of any long term health hazards, we strongly recommend that safety precautions are taken whenever the materials are handled.

**Exposure to dust from fibre which has been used at high temperatures may cause respiratory disease.**

**When handling fibre always use an approved mask, eye protection, gloves and long sleeved clothing.**

**Avoid breaking up waste material. Dispose of waste fibre in sealed containers.**

**After handling rinse exposed skin with water before washing gently with soap (not detergent). Wash work clothing separately.**

Before commencing any major repairs we recommend reference to the European Ceramic Fibre Industry Association Bulletin No. 11 and the UK Health and Safety Executive Guidance Note EH46.

We can provide further information on request. Alternatively our service division can quote for any repairs to be carried out at your premises or ours.

### 5.3 Temperature Controller Replacement

201. This controller is fitted to the back of the control panel; in many models this can be separated from the base by removal of two screws.



Before handling the controller: **wear an anti-static wrist strap** or otherwise avoid any possibility of damage to the unit by static electricity.

Refer to the detailed instructions supplied with the replacement controller.

2132, 2416, 2408 etc. Ease apart the two lugs at the side; grip the instrument and withdraw it from its sleeve; push in the replacement.

### 5.4 Solid-state Relay Replacement

Disconnect the furnace from the supply and remove the back panel from the case.

Make a note of how the wires are connected to the solid state relay, and disconnect them.

Remove the solid state relay from the base panel or aluminium plate.

Replace and reconnect the solid state relay ensuring that the heat-conducting thermal pad is sandwiched between the relay and the base panel or aluminium plate. Alternatively a thin layer of white, heat-conducting silicon paste may be applied between the new relay and the plate.

Replace the removed panel.



## 5.5 Thermocouple Replacement

Disconnect the furnace from the supply, and remove the end panels and back panel.

Make a note of the thermocouple connections. The negative leg of the thermocouple is marked blue. Compensating cable colour codings are:

<i>negative</i>	<i>positive (type K)</i>	<i>positive (type N)</i>
white	green	pink

Disconnect the thermocouple from its terminal block.

Withdraw the thermocouple from its sheath (the narrow-bore tube through the centre line of the furnace) and remove any broken bits of thermocouple.

Bend the new thermocouple carefully to match the shape of the original (working from the terminal end). Should the length differ from that of the original this will usually not be important provided that the thermocouple tip is within a tube diameter's distance from the furnace centre.

Insert the new thermocouple into position, restoring any removed porcelain spacers, and ensuring correct polarity.

Re-assemble the furnace.

## 5.6 Element Replacement



*Please see safety note 5.2 - please wear a face mask.*

Disconnect the furnace from the electrical supply.

Remove the end panels, the back panel and the instrument panel.

Disconnect all electrical leads from the terminal blocks on the furnace case. Note the colours and positions of the connecting leads to enable correct reassembly. Take care not to crack porcelain terminal blocks - use two spanners where appropriate.

Remove the thermocouple.

Remove 4 off screws. Two are accessible from inside and just above the instrument panel; the other two are opposite, at the back. Lift off the top cover.

The heating chamber body lies on two cradles with screws. Remove the four screws. Lift the chamber out of the furnace case.

Lay the chamber horizontally with the split in the cylindrical case uppermost. Remove the two metal end-caps. The case will spring open slightly. Remove the ceramic board disc from one end.

Cut through the outer wrap of blanket insulation. Note how the element tails are connected and disconnect all of them. Lift out the elements through the end of the cylindrical case. Check the cylindrical case and clean out as appropriate.

Remove any insulation sleeving from the old element tails and fit to the replacement element.

Slide in the new element(s). Close up the furnace again, refitting the terminal strip (where applicable) and the end-caps. Any cut made in the insulation should close up completely: if the insulation appears loose or damaged in any way, please contact our service division.

Reverse the rest of the disassembly process. Take care to make all connections to the correct terminals. Do not overtighten the connectors in porcelain terminal blocks.

Let the furnace heat up at its maximum rate to 900°C without interruption, and then soak for 1 hour. Fumes may be emitted: this should be done in conditions of good ventilation.

Check that the furnace is controlling properly to rule out the possibility that the element failed because of a fault in the control system.

If you have any problems with this procedure, please contact our service division.

### 5.7 **Fuse Replacement**

Fuses are marked on the circuit diagram (section 7.0) with type codes, e.g. F1, F2. A list of the correct fuses is given in section 8.1. *Depending on voltage, the different fuse types may or may not be fitted.*

If any fuse has failed, it is advisable for an electrician to check the internal circuits.

Replace any failed fuses with the correct type. For safety reasons do not fit larger capacity fuses without first consulting Carbolite.

The fuses are near the cable entry point, and access is by removal of the back panel of the base or control box.

## 6.0 FAULT ANALYSIS

### A. Furnace Does Not Heat Up

- |    |                                     |  |  |
|----|-------------------------------------|--|--|
| 1. | The <b>HEAT</b> light is <b>ON</b>  | → The heating element has failed   | → Check also that the SSR is working correctly   |
| 2. | The <b>HEAT</b> light is <b>OFF</b> | The controller shows a <b>very high temperature</b> or a code such as S.br | → The thermocouple has broken or has a wiring fault  |
|    |                                     | The controller shows a <b>low temperature</b>                              | → The door switch(es) (if fitted) may be faulty or need adjustment   |
|    |                                     |  | → The contactor (if fitted) may be faulty  |
|    |                                     |  | → The SSR could be failing to switch on due to internal failure, faulty logic wiring from the controller, or faulty controller           |
|    |                                     | There are no lights glowing on the controller                              | → The <b>SUPPLY</b> light is <b>ON</b> → The controller may be faulty or not receiving a supply due to a faulty switch or a wiring fault |
|    |                                     |  | → The <b>SUPPLY</b> light is <b>OFF</b> → Check the supply fuses and any fuses in the furnace control compartment                        |

### B. Furnace Overheats

- |    |   |   |  |
|----|---|---|--|
| 1. | The <b>HEAT</b> light goes <b>OFF</b> with the instrument switch        | → The controller shows a <b>very high</b> temperature | → The controller is faulty   |
|    |   | → The controller shows a <b>low</b> temperature       | → The thermocouple may have been shorted out or may have been moved out of the heating chamber |
|    |   |   | → The thermocouple may be mounted the wrong way round  |
|    |   |   | → The controller may be faulty   |
| 2. | The <b>HEAT</b> light <b>does not go off</b> with the instrument switch | → The SSR has failed “ON”                             | → Check for an accidental wiring fault which could have overloaded the SSR                     |



7.0 **CIRCUIT DIAGRAMS**

Safety Switches type A: a 2-pole Heater Switch is fitted directly in the element circuit in models up to 16A rating.

Safety Switch type B: a Heater Switch is fitted into the contactor coil circuit in models over 16A.

7.1 **Single Phase**

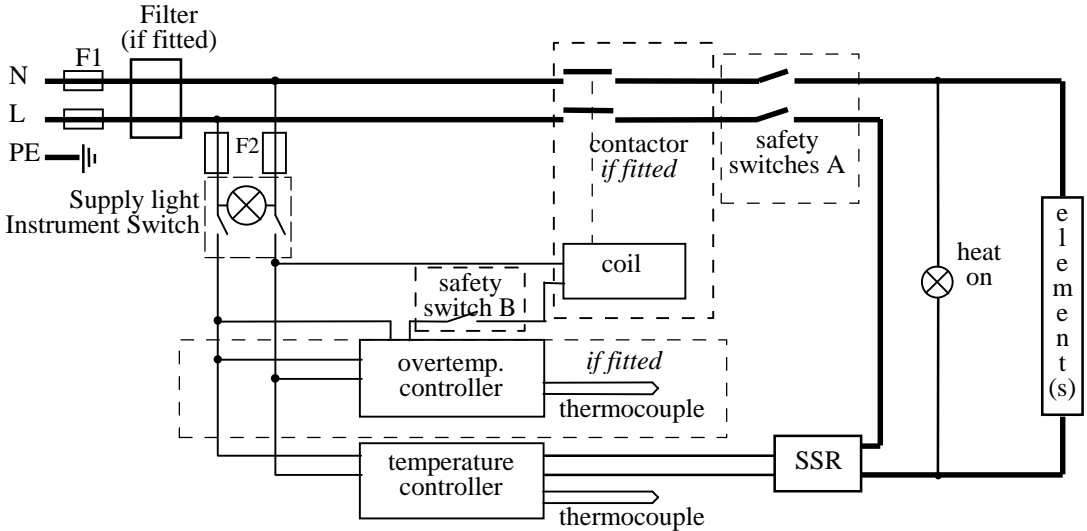

7.2 **3-phase with neutral**

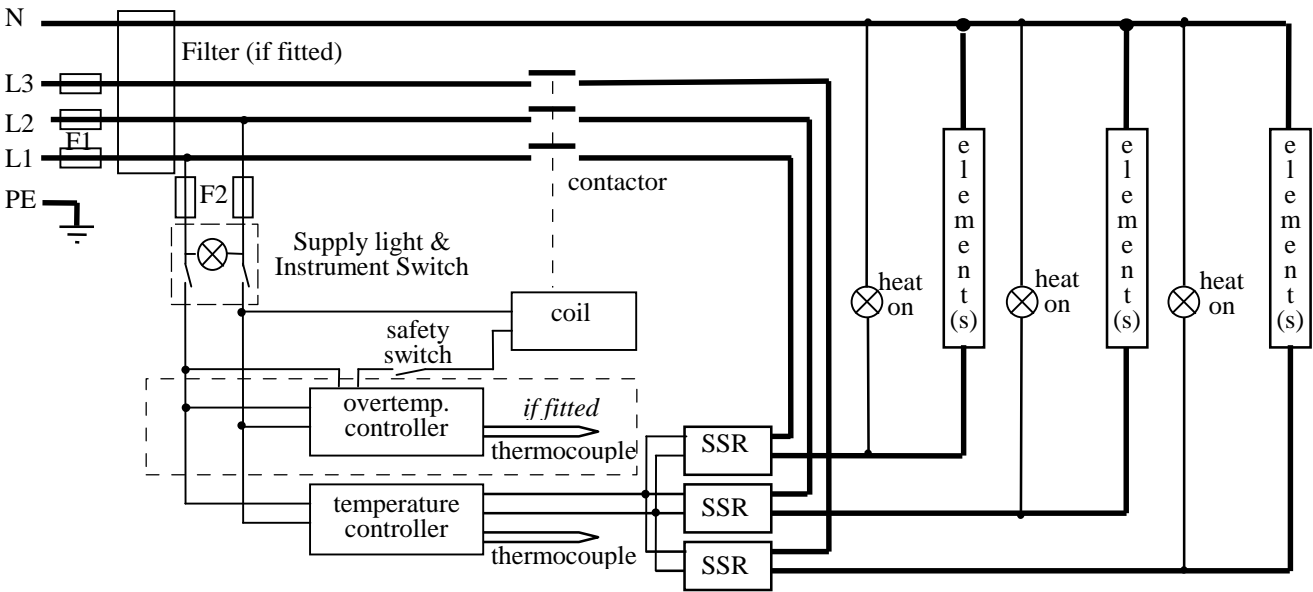

note on 3-phase: depending on filter(s) fitted, there may be 3 separate neutral wires from the elements to the neutral supply.

**7.3 3-phase without neutral (delta)**

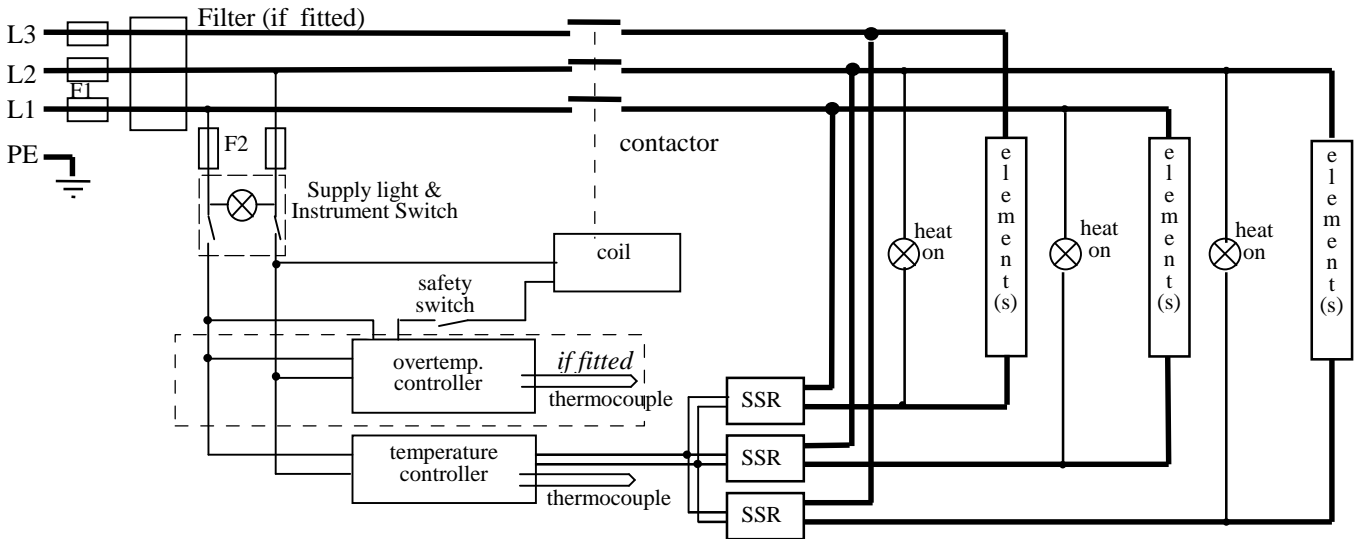

**7.4 3-phase without neutral (star – e.g. 380 to 415V)**

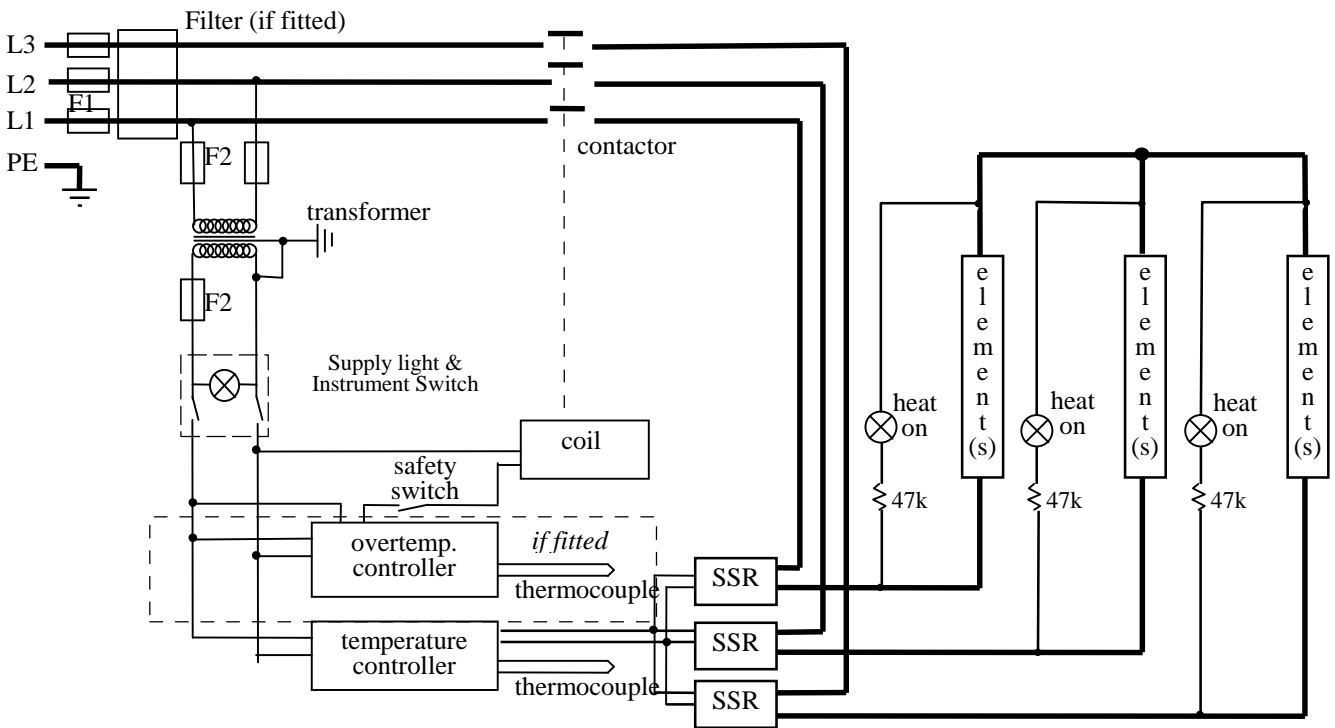

Note: in this configuration the fuses F2 on the supply side of the transformer may be GEC Safeclip, not 32 x 6mm glass as stated in section 8.1.

**7.5 Higher Voltages (e.g. 254V; 440V, 480V 3-phase)**

The diagram above (7.3) normally applies, with neutral (if present) not being used.

For single phase models of 254V or above, diagram 7.1 applies except that a control circuit transformer is included as in diagram 7.3.

## 8.0 FUSES & POWER SETTINGS

### 8.1 Fuses

*F1-F2: Refer to the circuit diagrams.*

<i>F1</i>	Internal supply fuses	Fitted if supply cable fitted. Fitted on board to some types of EMC filter.	on-board and up to 16 Amps: 32mm x 6mm type F other: GEC Safeclip
<i>F2</i>	Auxiliary circuit fuses	Fitted on board to some types of EMC filter. May be omitted up to 25Amp/phase supply rating.	2 Amps glass type F On board: 20mm x 5mm Other: 32mm x 6mm
	<b>Customer fuses</b>	Required if no supply cable fitted. Recommended if cable fitted.	See rating label for amperage; see table below for fuse rating.

Model	phases	Volts	Supply Fuse Rating
AGD 12/4	1-phase	220-240	20A
AGD 12/4	3-phase + N	380/220 - 415/240	7A
AGD 12/4	3-phase delta	220-240	12.5A

### 8.2 Power Settings

The power limit parameter  $\overline{PH}_i$  is usually inaccessible to the operator, with the exception of the case mentioned in section 4.5.

For all voltage the power limit is to be set at 100%.



Thank you for reading this data sheet.

For pricing or for further information, please contact us at our UK Office, using the details below.



**UK Office**

**Keison Products,**

**P.O. Box 2124, Chelmsford, Essex, CM1 3UP, England.**

**Tel: +44 (0)330 088 0560**

**Fax: +44 (0)1245 808399**

**Email: [sales@keison.co.uk](mailto:sales@keison.co.uk)**

Please note - Product designs and specifications are subject to change without notice. The user is responsible for determining the suitability of this product.