



Installation, Operation & Maintenance Instructions

Laboratory & Industrial High Temperature Ovens
and High Temperature Clean Room Ovens
LHT and HT models

This manual is for the guidance of operators of the above Carbolite products and should be read before the oven is connected to the electricity supply.

CONTENTS

Section		page
1.0	Symbols & Warnings	1
2.0	Installation	3
3.0	Operation	5
4.0	Maintenance	7
5.0	Repairs & Replacements	8
6.0	Fault Analysis	10
7.0	Circuit Diagrams	11
8.0	Fuses & Power Settings	13
9.0	Specifications	16

**Manuals are supplied separately for the temperature controller
(and overtemperature controller when fitted).**

Please read the controller manuals before operating the oven.

SYMBOLS & WARNINGS

1.1 Switches and Lights



Supply Light: when the oven is connected to the electrical supply the light in the adjacent switch glows

1.2 Warning Symbols

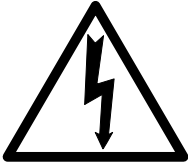

DANGER of electrical shock– read any warning printed by this symbol.



DANGER – hot surface. Read any warning printed by this symbol.
WARNING: all surfaces of an oven may be hot.



DANGER – read any warning printed by this symbol.

2.0 INSTALLATION

2.1 Unpacking & Handling

Lift the unit by its base. The door should not be used to support the equipment when moving it. Use two people to carry the oven where possible. Remove any packing material from the inner chamber before use.

Lift the unit by its base. Do not use the door or any other projecting cover or component to support the equipment when moving it. Use two people to carry the oven where possible. Remove any packing material from the inner chamber before use, and locate the shelves as required.

2.2 Siting & Setting Up

Place the oven on a level surface.

Ensure that there is free space around the oven. Ensure that any vents in the oven are not obscured.

Ensure that the oven is placed in such a way that it can be quickly switched off or disconnected from the electrical supply - see below.

2.3 Electrical Connections

Connection by a qualified electrician is recommended.

All ovens covered by this manual may be ordered for single phase A.C. supply, which may be Live to Neutral non-reversible, Live to Neutral reversible or Live to Live. Some models may be ordered for use on a three phase supply with neutral (e.g. 380/220V) or for three phase without neutral (delta); some for two phases out of a 3-phase + neutral supply.

Check the Oven rating label before connection. The supply voltage should agree with the voltage on the label, and the supply capacity should be sufficient for the amperage on the label.

The supply should be fused at the next size equal to or higher than the amperage on the label. A table of the most common fuse ratings is also given in section 8.1 of this manual. Where a supply cable is present there are internal supply fuses; customer fusing is preferred but not essential.

Oven with supply cable: either wire directly to an isolator or fit with a line plug.

Oven without supply cable: a permanent connection to a fused and isolated supply should be made to the internal terminals after temporary removal of the Oven back panel.

Connection by line plug: the plug should be within reach of the operator, and should be quickly removable.

Connection to isolating switch: this should operate on both conductors (single phase) or on all live conductors (three phase), and should be within reach of the operator.

The supply **MUST** incorporate an earth (ground).

CONNECTION DETAILS			<i>supply type</i>	
Supply	Terminal label	Cable colour	<i>Live-Neutral</i>	<i>Reversible or Live-Live</i>
<i>1-phase</i>	L	Brown	To live	to either power conductor
	N	Blue	To neutral	to the other power conductor
	PE	Green/Yellow	To earth (ground)	to earth (ground)
supply	Terminal label	Cable colour		
<i>2- or 3-phase</i>	L1	Black	to phase 1	
	L2	Black	to phase 2	
	L3	Black	to phase 3 <i>except 2-phase</i>	
	N	Light Blue	to neutral <i>except delta</i>	
	PE	Green/Yellow	to earth (ground)	

3.0 **OPERATION**

The instructions for operating the temperature controller are given in a separate manual.

If the oven is fitted with a time switch, see also the supplementary manual MS03.

If cascade control is fitted, see the supplementary manual MS07.

If the oven has variable speed fan, air extraction or stoving and curing options, please also see the appropriate section on the next page of this manual.

3.1 **Operating Cycle**

The oven is fitted with a combined Supply light and Instrument switch. The light is on whenever the oven is connected to the supply. The switch cuts off power to the controller(s).

The circulation fan operates when the instrument switch is switched on. In the LHT models the case cooling fans operate when the instrument switch is on.

Connect the oven to the electrical supply. The Supply light should glow .

Operate the instrument switch to activate the temperature controller; the O position is off, the I position on. The controller becomes illuminated and go through a short test cycle.

Adjust the temperature controller – see the controller manual.

Overtemperature option only. If the overtemperature controller has not yet been set as required, set it and activate it according to the instructions in the appropriate manual.

Unless a time switch is fitted and is off, the oven begins to heat up according to the controller set point or program.

To switch the oven off, set the Instrument switch to **O**. If the oven is to be left off, isolate it from the electrical supply.

DO NOT switch off if the temperature is above 300°C - damage could be caused to the fan and motor. Adjust the controller or the overtemperature controller to allow the temperature to fall.

3.2 **Overtemperature Control (if fitted)**

The overtemperature controller should typically be set at 15°C above the main controller. If an overtemperature condition occurs, check the possibility that the main control system has failed.

An overtemperature condition cuts off power to the heating elements. It is indicated by a light in the overtemperature controller flashing. To reset the condition, either allow the oven to cool, or increase the overtemperature setting, then follow the instructions in the appropriate manual.

3.3 **Explosive Vapours**



The standard models are not suitable for drying or heat treatment applications where vapours are released which are combustible or which can form explosive mixtures with air. For such applications only use models supplied specially for the purpose.

3.4 **Atmospheres**

When an optional gas inlet is fitted there is a label near the inlet saying "INERT GAS ONLY". In practice *inert* or *oxidising* gases may be used, but not combustible or toxic gases. The oven chambers are not gas tight, so it should be understood that gas usage may be high, and that the chamber is likely always to contain some air. Residual oxygen levels of 1% are to be expected.

3.5 Variable Speed Fan Option

When this is ordered, a variable speed control is fitted in the fan circuit. Operation of the control is self-explanatory.

Please note that there is a minimum setting at which the fan motor starts up when the oven is switched on. Find this setting by experiment, and mark the position on the control or front panel.

It is unlikely that a control setting of less than 50% would be required, as there would be very little air flow around the oven.

3.6 Exhaust Fan Option

Start the extraction unit using the amber switch on the control panel; this is only functional when the instrument switch is on.

The amount of air exhaust can be controlled by adjusting the slider under the exhaust box.

When the exhaust fan is turned on, there may be a drop in internal temperature before the oven recovers to the setpoint value.

When working near to the maximum temperature, the airflow should be small to reduce the amount of energy wasted in heating air.

3.7 Stoving and Curing Option

The oven is fitted with an explosion relief panel and a powered exhaust fan. The exhaust fan is physically similar to that described above.

With this option the fan runs all the time that the oven is switched on.

A pressure switch detects that there is sufficient air flow through the chamber, and prevents the oven from heating if the exhaust fan is not working correctly. If the pressure switch does not detect sufficient air flow, a fault light comes on and the oven is prevented from heating up.

At least 200mm free space must be left at the back and side of the oven to allow the explosion relief panel to break out if there is a rapid build up of pressure inside the chamber.

4.0 MAINTENANCE

4.1 General Maintenance

No routine maintenance is required other than the occasional replacement of consumable items.

The oven outer surface may be cleaned with a damp cloth. Do not allow water to enter the interior of the case. Do not clean with organic solvents.

The fan motor is sealed for life; no lubrication is required.

4.2 Calibration

After prolonged use the controller and/or thermocouple could require recalibration. This would be important for processes which require accurate temperature readings. A quick check using an independent thermocouple and temperature indicator should be made from time to time to determine whether full calibration is required.

For a quick check of the temperature shown by the control thermocouple and oven controller, a portable temperature indicator and probe thermocouple may be used.

Depending on the controller, the controller manual may contain calibration instructions.

4.3 After Sales Service

Carbolite's service division (Thermal Engineering Services) has a team of Service Engineers capable of repair, calibration and preventive maintenance of furnace and oven products at our customers' premises throughout the world. We also sell spares by mail order. A telephone call or fax often enables a fault to be diagnosed and the necessary spare part despatched.

Each furnace has its own record card at Carbolite. In all correspondence please quote the serial number, model type and voltage given on the rating label of the furnace. The serial number and model type are also given on the front of this booklet when supplied with a furnace.

To contact Thermal Engineering Services or Carbolite see the back page of this manual.

4.4 Recommended Spares Kits

Carbolite can supply individual spares, or a kit of the items most likely to be required. Ordering a kit in advance can save time in the event of a breakdown. Each kit comprises a fan and motor assembly, a thermocouple, a solid state relay, an instrument switch, an element or set of elements, and a door seal. Individual spares are also available.

When ordering spares please quote the model details as requested above.

4.5 Power Adjustment

The control system incorporates electronic power limiting, but in these models the power limit is set to 100% and the power limit parameter OP.Hi may be inaccessible to the operator.

Rarely, in the case of uncommon voltages (e.g. outside the range 220-240V or the 3-phase equivalent), the power limit parameter may be set to a value other than 100%. Do not increase the value to 100%. See section 8.2 for details of any power limit settings.

Occasionally the power limit is set to zero to permit demonstration of the controls without the heating elements taking power. In this case the power limit is accessible to the operator and may be reset to its standard value, usually 100: see section 8.2.

5.0 REPAIRS & REPLACEMENTS

5.1 Safety Warning – Disconnection from Supply

Always ensure that the oven is disconnected from the supply before repair work is carried out.



5.2 Safety Warning - Refractory Fibrous Insulation

This oven contains refractory fibres in its thermal insulation. These materials may be in the form of fibre blanket or felt, vacuum formed board or shapes, mineral wool slab or loose fill fibre.



Normal use of the oven does not result in any significant level of airborne dust from these materials, but much higher levels may be encountered during maintenance or repair.

Whilst there is no evidence of any long term health hazards, we strongly recommend that safety precautions are taken whenever the materials are handled.

Exposure to dust from fibre which has been used at high temperatures may cause respiratory disease.

When handling fibre always use an approved mask, eye protection, gloves and long sleeved clothing.

Avoid breaking up waste material. Dispose of waste fibre in sealed containers.

After handling rinse exposed skin with water before washing gently with soap (not detergent). Wash work clothing separately.

Before commencing any major repairs we recommend reference to the European Ceramic Fibre Industry Association Bulletin No. 11 and the UK Health and Safety Executive Guidance Note EH46.

We can provide further information on request. Alternatively our service division can quote for any repairs to be carried out at your premises or ours.

5.3 Panel Removal



Disconnect the oven from the electrical supply.

Control panel - LHT Models. Open the door and remove two screws located in recesses on the left side of the control panel (these screws are covered with plastic caps). Lift the panel, pull forward the bottom of the panel, and lower the panel to disengage it from the top of the body. Note that the panel remains connected by wiring. Do not disconnect any wiring without first making a careful note of all the connections.

Control panel - HT models. Remove the screws holding the panel. Note that the panel remains connected by wiring. Do not disconnect any wiring without first making a careful note of all the connections.

Internal Element Cover. Open the door. Remove any screws holding the panel and any clips holding thermocouples in position. Remove the cover.

5.4 Temperature Controller Replacement

200 & 201. These controllers are fitted to the back of the control panel, which can be removed as given above.



Before handling the controller: **wear an anti-static wrist strap** or otherwise avoid any possibility of damage to the unit by static electricity.

Refer to the instructions supplied with the replacement controller.

2132, 2416, 2408 etc. Ease apart the two lugs at the side; grip the instrument and withdraw it from its sleeve; push in the replacement.

5.5 Solid-state Relay Replacement

Remove the control panel as given above. Make a note how the wires are connected to the solid state relay, and disconnect them.

Remove the solid state relay from the aluminium plate.

Replace and reconnect the solid state relay ensuring that the heat-conducting thermal pad is sandwiched between the relay and the base panel or aluminium plate. Alternatively a thin layer of white, heat-conducting silicon paste may be applied between the new relay and the plate.

The new solid state relay contains a built-in MOV which protects it from short periods of excess voltage. If the old relay had a separate disc-shaped "MOV" connected between the high voltage terminals of the old relay, discard the old MOV.

Replace the removed panel.

5.6 Thermocouple Replacement

Remove the control panel and the internal cover as given above.

Make a note of the thermocouple connections, and how the thermocouple is placed and fixed. Colour codings are:

<i>negative</i>	<i>positive (type K)</i>
white	green

Disconnect the thermocouple from its controller terminals or terminal block.

Re-assemble with the new thermocouple observing the colour coding.

5.7 Element Replacement

Remove the control panel and the internal cover as given above. LHT: the element terminals are low down in the side compartment. HT: the element terminals are accessed from the back.

Disconnect the wires from the element terminals. Remove any starlock washers - these may need to be cut with wire cutters. Remove any clips holding the element inside the chamber, and withdraw the element.

Reverse the procedure with the new element.

Run the oven at a low temperature and check that it is controlling properly, to find out whether the element failure was caused by a fault in the control circuit.

6.0 FAULT ANALYSIS

A. Oven Does Not Heat Up

- | | | |
|--|--|--|
| 1. The SUPPLY light is OFF | → No power from the supply | → Check the fuses in the supply line |
| 2. The SUPPLY light is ON | → The controller shows a very high temperature or a code such as S.br | → The thermocouple has broken or has a wiring fault |
| | → The controller shows a low temperature | → The SSR could be failing to switch on due to internal failure, faulty logic wiring from the controller, or faulty controller |
| | → There are no lights glowing on the controller | → The controller may be faulty or not receiving a supply due to a faulty switch or a wiring fault |

B. Oven Overheats

- | | | |
|---|---|--|
| 1. Oven only heats up when the instrument switch is ON | → The controller shows a very high temperature | → The controller is faulty |
| | → The controller shows a low temperature | → The thermocouple may have been shorted out or may have been moved out of the oven
→ The thermocouple may be mounted the wrong way round
→ The controller may be faulty |
| 2. Oven heats up when the instrument switch is OFF | → The SSR has failed "ON" | → Check for an accidental wiring fault which could have overloaded the SSR |

7.0 CIRCUIT DIAGRAMS

7.1 Single Phase

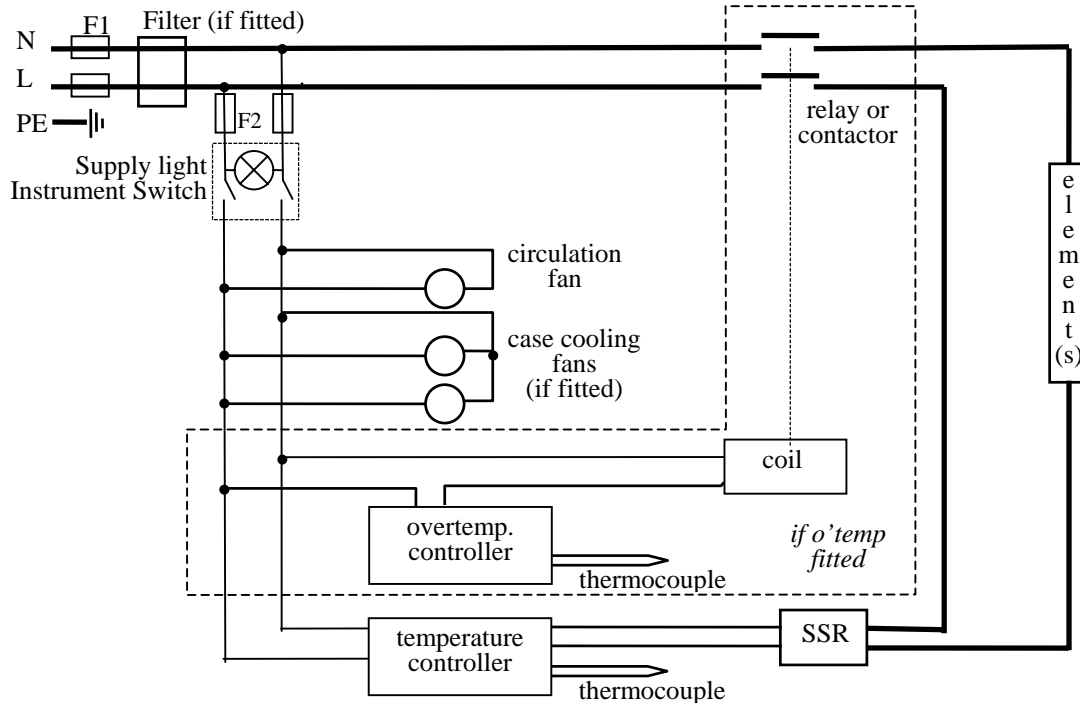

7.2 Two-phase with Neutral

As 3-phase with neutral (7.4), but with phase L3 not present, and with two SSRs and element circuits.

7.3 Three Phase with Neutral

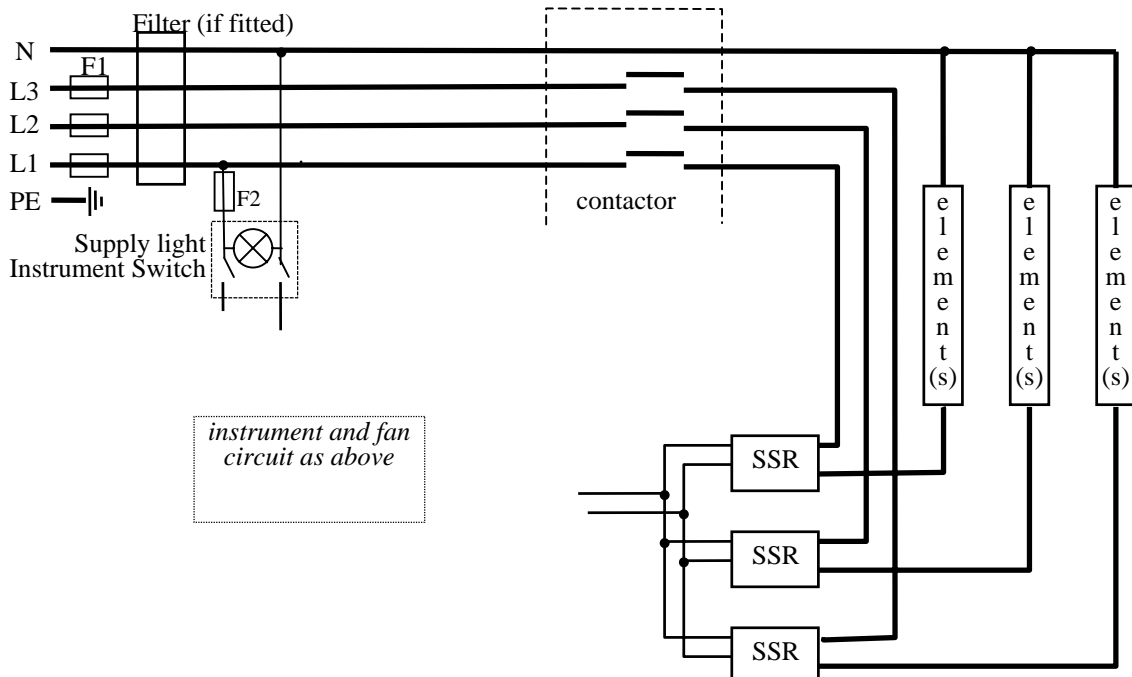

note on 2- or 3-phase: depending on EMC filter, there may be 2 or 3 neutral wires from the elements to the filter and terminal blocks

7.4 Three Phase without Neutral (delta e.g. 208-240V)

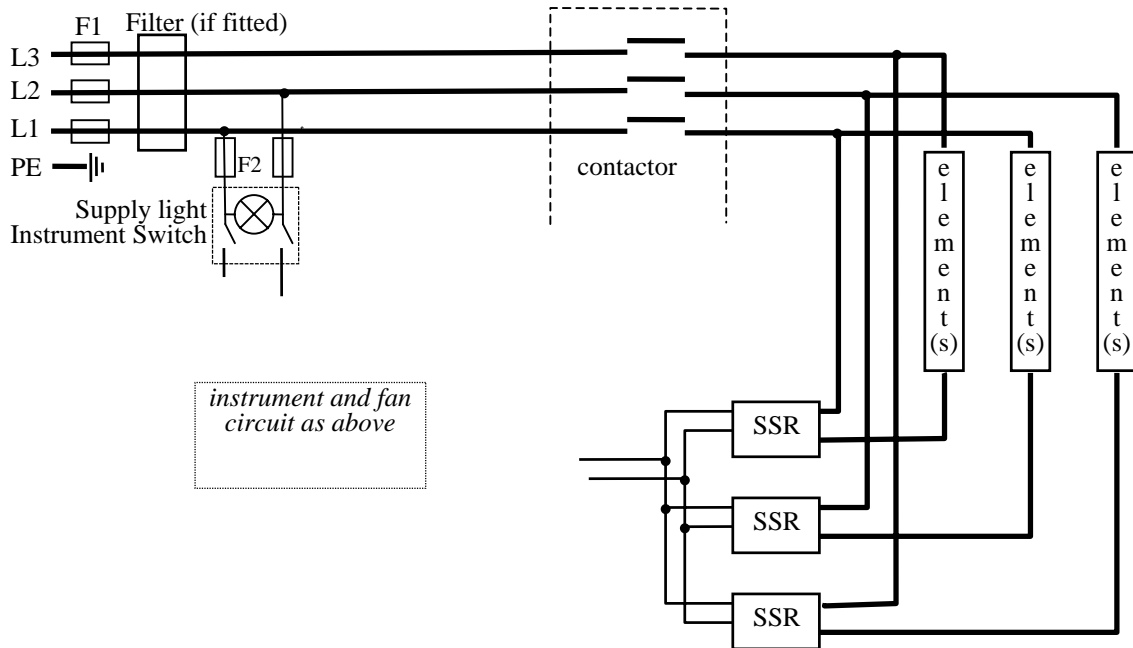

7.5 Three phase without Neutral (star – e.g. 380-415V)

The circuit is similar to 7.4, but the “neutral” ends of the elements are not connected to a neutral terminal block.

The control circuit contains an isolating transformer to reduce the control voltage to 240V or similar.

7.6 Higher Voltages (e.g.254V)

The control circuit contains an isolating transformer to reduce the control voltage to 240V or similar.

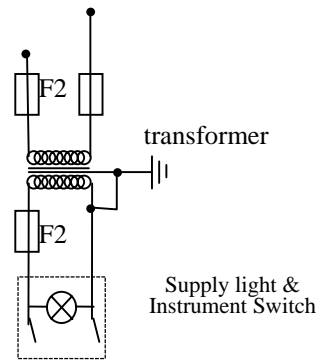

7.7 Stoving & Curing

The following addition is made to the circuit.

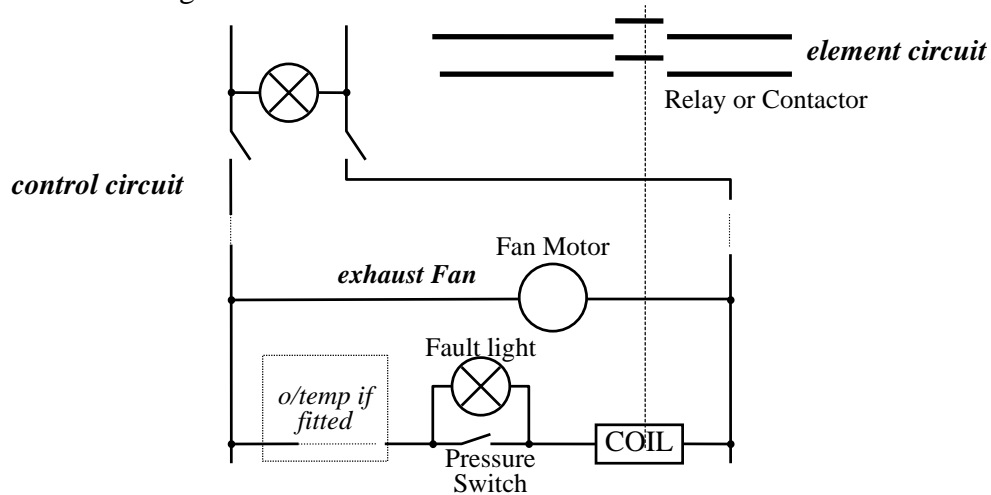

8.0 FUSES & POWER SETTINGS

8.1 Fuses

F1-F2: Refer to the circuit diagrams.

<i>F1</i>	Internal supply fuses	Fitted if supply cable fitted. Fitted on board to some types of EMC filter.	on-board and up to 16 Amps: 32mm x 6mm type F other: GEC Safeclip
<i>F2</i>	Auxiliary circuit fuses	Fitted on board to some types of EMC filter. May be omitted up to 25Amp/phase supply rating.	2 Amps glass type F On board: 20mm x 5mm Other: 32mm x 6mm
	Customer fuses	Required if no supply cable fitted. Recommended if cable fitted.	See rating label for amperage; see table below for fuse rating.

Model	phases	Volts	Supply Fuse rating
LHT4/30	1-phase	220-240	5A
LHT4/60	1-phase	220-240	7A
LHT4/120	1-phase	220-240	10A
LHT5/30	1-phase	220-240	10A
LHT5/60	1-phase	220-240	10A
LHT5/120	1-phase	220-240	12.5A
LHT6/30	1-phase	220-240	10A
LHT6/60	1-phase	220-240	10A
LHT6/120	1-phase	220-240	12.5A
HT4/28	1-phase	220-240	5A
HT4/95	1-phase	220-240	12.5A
HT4/220	1-phase	380/220 - 415/240	12.5A
HT5/28	1-phase	220-240	10A
HT5/95	1-phase	220-240	12.A
HT5/220	1-phase	220-240	20A
HT5/220	2-phase+N	380/220 -415/240	10A
HT6/28	1-phase	220-240	10A
HT6/95	1-phase	220-240	20A
HT6/95	2-phase+N	380/220 -415/240	10A
HT6/220	1-phase	220-240	30-32A
HT6/220	3-phase+N	380/220 - 415/240	15-16A
HT6/220	3-phase delta	220-240	20A

8.2 Power Settings

All models are designed for a power limit (OP.Hi) of 100% with the following exceptions to date:

- any model on 254V or 440V: 89%

9.0 SPECIFICATIONS

Carbolite reserves the right to change specifications without notice.

9.1 Models Covered by this Manual

MODEL	Max. Temp. (°C)	Max. Power (kW)	Chamber Size (mm)			Approx. Capacity (l)	Net Weight (kg)
			H	W	D		
<i>Laboratory High Temperature Ovens</i>							
LHT4/30	400	1	300	300	310	28	75
LHT4/60	400	1.5	400	400	410	66	100
LHT4/120	400	2.25	650	460	410	128	137
LHT5/30	500	2	300	300	310	28	75
LHT5/60	500	2.5	400	400	410	66	100
LHT5/120	500	3	650	460	410	128	137
LHT6/30	600	2	300	300	310	28	75
LHT6/60	600	2.5	400	400	410	66	100
LHT6/120	600	3	650	460	410	128	137
<i>Industrial High Temperature Ovens</i>							
HT4/28	400	1	305	305	305	28	62
HT4/95	400	3	455	455	455	94	144
HT4/220	400	3	610	610	610	227	200
HT5/28	400	2	305	305	305	28	62
HT5/95	500	3	455	455	455	94	144
HT5/220	500	4.5	610	610	610	227	200
HT6/28	600	2	305	305	305	28	62
HT6/95	600	4.5	455	455	455	94	144
HT6/220	600	6	610	610	610	227	200
<i>High Temperature Clean Room Ovens</i>							
HT4/28CR to HT6/220CR							
The size and power data is the same as for Industrial High Temperature Ovens							

9.2 Environment

The ovens contain electrical parts and should be stored and used in indoor conditions as follows:

temperature: 5°C - 40°C

relative humidity: maximum 80% up to 31°C decreasing linearly to 50% at 40°C