



# Installation, Operation & Maintenance Instructions

## Ovens & Incubators Peak Series

This manual is for the guidance of operators of the above Carbolite products and should be read before the oven is connected to the electricity supply.

---

### CONTENTS

Section		Page
1.0	Symbols & Warnings	1
2.0	Installation	3
3.0	Operation	5
4.0	Maintenance	8
5.0	Repairs & Replacements	9
6.0	Fault Analysis	11
7.0	Circuit Diagrams	12
8.0	Fuses & Power Settings	15
9.0	Specifications	16

---

**Manuals are supplied separately for the temperature controller (and overtemperature controller when fitted).**

Please read the controller manuals before operating the oven.

1.0

**SYMBOLS & WARNINGS**

**1.1 Switches and Lights**



Supply Light: when the oven is connected to the electrical supply the light in the adjacent switch glows

**1.2 Warning Symbols**

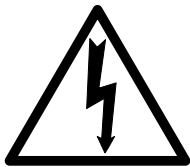

DANGER of electrical shock– read any warning printed by this symbol.



DANGER – hot surface. Read any warning printed by this symbol.  
WARNING: all surfaces of an oven may be hot.



DANGER – read any warning printed by this symbol.

## 2.0 INSTALLATION

### 2.1 Unpacking & Handling

Remove the shelves and runners from the packaging before attempting to move the equipment.

Lift the unit by its base. The door should not be used to support the equipment when moving it. Use two people to carry the oven where possible. Remove any packing material from the inner chamber before use.

### 2.2 Siting & Setting Up

Place the oven on a level surface. If overtemperature protection is not fitted, ensure that the unit can be directly observed.

Ensure that there is at least 50mm free space behind and around the oven. There are vents in the back that must not be obstructed. Some models have protruding fan motor housings: these housings must be in an area of good ventilation.

Ensure that the oven is placed in such a way that it can be quickly switched off or disconnected from the electrical supply - see below.

*Except 800 litre models:* The ends of the runners should be inserted into the vertical columns of holes simultaneously at the front and the back. The bar should then be rotated through 90° in a downwards direction to secure it in place. The shelves slide onto the runners such that the spurs on the lower side of the shelf are under the bar at the back; this prevents the shelf from tilting forwards when partially withdrawn.

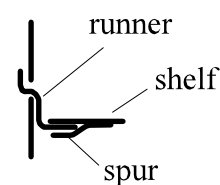

### 2.3 Electrical Connections

*Connection by a qualified electrician is recommended.*

All ovens covered by this manual may be ordered for single phase A.C. supply, which may be Live to Neutral non-reversible, Live to Neutral reversible or Live to Live. Model PF400 can be supplied for use on two phases out of a three phase with neutral supply - one phase is left unused. Model PF800 can be supplied for use on a three phase supply.

Check the oven rating label before connection. The supply voltage should agree with the voltage on the label, and the supply capacity should be sufficient for the amperage on the label.

The supply should be fused at the next size equal to or higher than the amperage on the label. A table of the most common fuse ratings is also given in section 8.1 of this manual. Where a supply cable is present there are internal supply fuses; customer fusing is preferred but not essential.

Oven with supply cable: either wire directly to an isolator or fitted with a line plug.

Oven without supply cable: a permanent connection to a fused and isolated supply should be made to the internal terminals after temporary removal of the back panel.

Connection by line plug: the plug should be within reach of the operator, and should be quickly removable.

Connection to isolating switch: this should operate on both conductors (single phase) or on all live conductors (three phase), and should be within reach of the operator.

The supply **MUST** incorporate an earth (ground).

CONNECTION DETAILS			<i>supply type</i>	
<b>Supply</b>	<b>Terminal label</b>	<b>Cable colour</b>	<i>Live-Neutral</i>	<i>Reversible or Live-Live</i>
<b>1-phase</b>	L	Brown	To live	to either power conductor
	N	Blue	To neutral	to the other power conductor
	PE	Green/Yellow	To earth (ground)	to earth (ground)
<b>2- or 3-ph</b>	L1	Black	to phase 1	
	L2	Black	to phase 2	
	L3	Black	to phase 3 <i>except 2-phase</i>	
	N	Light Blue	to neutral <i>except delta</i>	
	PE	Green/Yellow	to earth (ground)	

DO NOT connect an oven ordered for three phase use to a single phase supply or to the wrong type of three phase supply.

### 3.0 **OPERATION**

*The instructions for operating the temperature controller are given in a separate manual.*

*If the oven is fitted with a time switch, see also the supplementary manual MS03.*

*If cascade control is fitted, see the supplementary manual MS07.*

*If the oven has variable speed fan, air extraction or stoving and curing options, please also see the appropriate section on the next page of this manual.*

#### 3.1 **Operating Cycle**

The oven is fitted with a combined Supply light and Instrument switch. The light is on whenever the oven is connected to the supply. The switch cuts off power to the controller(s).

If the oven has fan-assisted circulation, the fan operates when the instrument switch is switched on.

Connect the oven to the electrical supply. The Supply light should glow.

Operate the instrument switch to activate the temperature controller; the **O** position is *off*, the **I** position *on*. The controller becomes illuminated and goes through a short test cycle.

Adjust the temperature controller – see the controller manual.

*Overtemperature option - Hydraulic thermostat.* Set the rotary dial to the desired protection temperature.

*Overtemperature option - Digital.* If the overtemperature controller has not yet been set as required, set it and activate it according to the instructions in the appropriate manual.

Unless a time switch is fitted and is off, the oven starts to heat up according to the controller set point or program.

To switch the oven off, set the Instrument switch to **O**. If the oven is to be left off, isolate it from the electrical supply.

#### 3.2 **Overtemperature Control (if fitted)**

The overtemperature controller should typically be set at 15°C above the main controller. If an overtemperature condition occurs, always investigate the possibility that the main control system has failed.

An overtemperature condition always cuts off power to the heating elements. To reset the condition, first either allow the oven to cool, or increase the overtemperature setting.

*Hydraulic thermostat.* If the overtemperature trip operates then a click occurs and a warning light near the thermostat lights up; the reset button on the thermostat pops out. Reset by pressing the button. In some models the reset button is directly accessible. In others it is necessary to turn the thermostat dial till the hole lines up with the reset button and press it using a small diameter rod.

*Digital.* A light in the overtemperature controller flashes. Reset the overtemperature controller according the instructions in the appropriate manual.

#### 3.3 **Vents**

On the back of the unit are two vents, inlet and exhaust. The inlet vent is covered by a baffle that should be left in place.

The exhaust vent is closed by a butterfly valve that can be controlled from the front panel. Rotate the knob clockwise to open the vent, anticlockwise to close.

In non-fan models there is only a small flow of air through the chamber. With fan versions, fumes are pushed out through the exhaust vent by fan action, and drawn in through the inlet vent.

### 3.4 Temperature Uniformity

Where accurate temperature control of the load is important, use the central part of the chamber and place or distribute the load to allow free air circulation. Do not place loads on the chamber floor: use the bottom shelf.

### 3.5 Explosive Vapours



The standard models are not suitable for drying or heat treatment applications where vapours are released that are combustible or that can form explosive mixtures with air. For such applications only use models supplied with the stoving and curing option.

### 3.6 Atmospheres

When an optional gas inlet is fitted there is a label near the inlet saying "INERT GAS ONLY". In practice *inert* or *oxidising* gases may be used, but *not combustible or toxic gases*. The oven chambers are not gas tight, so it should be understood that gas usage may be high, and that the chamber is likely always to contain some air. Residual oxygen levels of 1% are to be expected.

### 3.7 Variable Speed Fan Option

When this is ordered, a variable speed control is fitted in the fan circuit. Operation of the control is self-explanatory.

Please note that there is a minimum setting at which the fan motor starts up when the oven is switched on. Find this setting by experiment, and mark the position on the control or front panel.

It is unlikely that a control setting of less than 50% would ever be required, as there would be very little air flow inside the oven.

### 3.8 Fan Exhaust and Moisture Extraction Options

When one of these options is fitted a vent duct at the back adds 45mm to the unit depth. 25mm free space should be left behind the vent to prevent damage. The motor and fan box and outlet vent are on the top of the unit, adding 270mm height. The outlet vent is a 64mm o/d tube to which suitable ducting can be connected if required.

Please note that the heater element power rating may be increased; check the oven rating label for power and fuse requirements.

Start the extraction unit using the amber switch on the control panel; this is only functional when the instrument switch is on.

The amount of air exhaust can be controlled by adjusting the vent control knob on the control panel.

When the unit is turned on, there may be a drop in internal temperature before the oven recovers to the setpoint value.

### 3.9 Stoving and Curing Option

The oven is fitted with an explosion relief panel and a powered exhaust fan. The exhaust fan is physically similar to that described above.

With this option the fan runs all the time that the oven is switched on.

A pressure switch detects that there is sufficient air flow through the chamber, and prevents the oven from heating if the exhaust fan is not working correctly. If the pressure switch does not detect sufficient air flow, a fault light comes on and the oven is prevented from heating up.

At least 200mm free space must be left at the back and side of the oven to allow the explosion relief panel to break out if there is a rapid build up of pressure inside the chamber.

### **3.10 Cooled Incubator Models**

The incubator is designed to run at a constant temperature; the cooling system is not designed for cooling the chamber down from high temperatures.

Select the desired temperature on the temperature controller. If this is below 45°C switch on the cooling unit using the switch marked “\*” on the front panel. If the desired temperature is above 45°C the cooling facility is normally not required and may be switched off.

When switched on, the cooling unit is designed to run all the time, and the heaters are used to balance the cooling load and maintain a stable temperature.

The optional defrost timer (when fitted) is a 2-hour time clock set to switch off the cooling system for at least quarter of an hour every 24 hours. This allows the cooling unit to defrost regularly.

### 4.0 MAINTENANCE

#### 4.1 General Maintenance

No routine maintenance is required other than the occasional replacement of consumable items.

The oven outer surface may be cleaned with a damp cloth. Do not allow water to enter the interior of the case. Do not clean with organic solvents.

Fan models: the motor is sealed for life; no lubrication is required.

#### 4.2 Calibration

After prolonged use the controller and/or thermocouple could require recalibration. This would be important for processes that require accurate temperature readings. A quick check using an independent thermocouple and temperature indicator should be made from time to time to determine whether full calibration is required.

For a quick check of the temperature shown by the control thermocouple and oven controller, a portable temperature indicator and probe thermocouple may be used. Carbolite can supply these items.

Depending on the controller, the controller manual may contain calibration instructions.

#### 4.3 After Sales Service

Carbolite's service division (Thermal Engineering Services) has a team of Service Engineers capable of repair, calibration and preventive maintenance of furnace and oven products at our customers' premises throughout the world. We also sell spares by mail order. A telephone call or fax often enables a fault to be diagnosed and the necessary spare part despatched.

Each oven has its own record card at Carbolite. In all correspondence please quote the serial number, model type and voltage given on the rating label of the oven. The serial number and model type are also given on the front of this booklet when supplied with an oven.

To contact Thermal Engineering Services or Carbolite see the back page of this manual.

#### 4.4 Recommended Spares Kits

Carbolite can supply individual spares, or a kit of the items most likely to be required. Ordering a kit in advance can save time in the event of a breakdown. Each kit comprises a thermocouple, a solid state relay, an instrument switch, an element or set of elements, and a door seal; for fan models the kit includes a fan and motor assembly. Individual spares are also available.

When ordering spares please quote the model details as requested above.

#### 4.5 Power Adjustment

The control system incorporates electronic power limiting, but in these models the power limit is set to 100%. The power limit parameter OP.Hi may be accessible to the operator, but should not generally be altered.

Rarely, in the case of uncommon voltages (e.g. outside the range 220-240V or the 3-phase equivalent), the power limit parameter may be set to a value other than 100%. Do not increase the value to 100%. See section 8.2 for details of any power limit settings.

Occasionally the power limit is set to zero to permit demonstration of the controls without the heating elements taking power. In this case the power limit is accessible to the operator and may be reset to its standard value, usually 100: see section 8.2.

## 5.0 REPAIRS & REPLACEMENTS

### 5.1 Safety Warning – Disconnection from Supply

Always ensure that the oven is disconnected from the supply before repair work is carried out.



### 5.2 Safety Warning - Refractory Fibrous Insulation

This oven contains refractory fibres in its thermal insulation. These materials may be in the form of fibre blanket or felt, vacuum formed board or shapes, mineral wool slab or loose fill fibre.



Normal use of the oven does not result in any significant level of airborne dust from these materials, but much higher levels may be encountered during maintenance or repair.

Whilst there is no evidence of any long term health hazards, we strongly recommend that safety precautions are taken whenever the materials are handled.

**Exposure to dust from fibre that has been used at high temperatures may cause respiratory disease.**

**When handling fibre always use an approved mask, eye protection, gloves and long sleeved clothing.**

**Avoid breaking up waste material. Dispose of waste fibre in sealed containers.**

**After handling rinse exposed skin with water before washing gently with soap (not detergent). Wash work clothing separately.**

Before commencing any major repairs we recommend reference to the European Ceramic Fibre Industry Association Bulletin No. 11 and the UK Health and Safety Executive Guidance Note EH46.

We can provide further information on request. Alternatively our service division can quote for any repairs to be carried out at your premises or ours.

### 5.3 Panel Removal



Disconnect the oven from the electrical supply.

Control panel. Open the door and remove two screws located in recesses on the left side of the control panel (these screws are covered with plastic caps). Lift the panel, pull forward the bottom of the panel, and lower the panel to disengage it from the top of the body. Note that the panel remains connected by wiring. Do not disconnect any wiring without first making a careful note of all the connections.

Internal Element Cover. Open the door. Side cover (fan models): remove any screws holding the panel. Bottom cover (non-fan): no screws; the panel clips into place. Remove the cover.

### 5.4 Temperature Controller Replacement

200 & 201. These controllers are fitted to the back of the control panel, which can be removed as given above.



Before handling the controller: **wear an anti-static wrist strap** or otherwise avoid any possibility of damage to the unit by static electricity.

Refer to the instructions supplied with the replacement controller.

2132, 2416, 2408 etc. Ease apart the two lugs at the side; grip the instrument and withdraw it from its sleeve; push in the replacement.

### 5.5 Hydraulic Thermostat Replacement (if fitted)

Remove the control panel as given above. Also remove the internal element cover.

Pull off the knob from the thermostat. Remove the fixing screws. Disconnect any fixing clips or screws inside the oven chamber, and ease out the capillary tube. Remove the thermostat.

Replace by reversal of the procedure.

### 5.6 Solid-state Relay Replacement

Remove the control panel as given above. Make a note how the wires are connected to the solid state relay, and disconnect them.

Remove the solid state relay from the aluminium plate.

Replace and reconnect the solid state relay ensuring that the heat-conducting thermal pad is sandwiched between the relay and the base panel or aluminium plate. Alternatively a thin layer of white, heat-conducting silicon paste may be applied between the new relay and the plate.

The new solid state relay contains a built-in MOV which protects it from short periods of excess voltage. If the old relay had a separate disc-shaped "MOV" connected between the high voltage terminals of the old relay, discard the old MOV.

Replace the removed panel.

### 5.7 Thermocouple Replacement

Remove the control panel and the internal cover as given above.

Make a note of the thermocouple connections, and how the thermocouple is placed and fixed. Colour codings are:

<i>negative</i>	<i>positive (type K)</i>
white	green

Disconnect the thermocouple from its controller terminals or terminal block.

Re-assemble with the new thermocouple observing the colour coding.

### 5.8 Element Replacement

Remove the control panel and the internal cover as given above. The element terminals are low down in the side compartment.

Disconnect the wires from the element terminals. Remove any starlock washers - these may need to be cut with wire cutters. Remove any clips holding the element inside the chamber, and withdraw the element.

Reverse the procedure with the new element.

Run the oven at a low temperature and check that it is controlling properly, to find out whether the element failure was caused by a fault in the control circuit.

### 5.9 Fuse Replacement

Models up to 200 litre: remove the smaller of the two back panels. Larger models: remove the side panel of the control compartment.

Depending on the model, supply fuses and control circuit fuses may be mounted in their own holders, or may be on a circuit board that contains an EMC filter. The fuses are marked with their ratings.

Take care not to disconnect the wires leading from the EMC filter without first recording their positions: they must be reconnected to the correct terminals.

## 6.0 FAULT ANALYSIS

### A. Oven Does Not Heat Up

- |  |  |  |
|--|--|--|
| 1. The <b>SUPPLY</b> light is <b>OFF</b> | → No power from the supply   | → Check the fuses in the supply line   |
| 2. The <b>SUPPLY</b> light is <b>ON</b>  | → The controller shows a <b>very high temperature</b> or a code such as S.br | → The thermocouple has broken or has a wiring fault  |
|  | → The controller shows a <b>low temperature</b>                              | → The SSR could be failing to switch on due to internal failure, faulty logic wiring form the controller, or faulty controller |
|  | → There are no lights glowing on the controller                              | → The controller may be faulty or not receiving a supply due to a faulty switch or a wiring fault                              |

### B. Oven Overheats

- |   |   |   |
|---|---|---|
| 1. Oven only heats up when the instrument switch is <b>ON</b> | → The controller shows a <b>very high temperature</b> | → The controller is faulty  |
|   | → The controller shows a <b>low temperature</b>       | → The thermocouple may have been shorted out or may have been moved out of the oven |
|   |   | → The thermocouple may be mounted the wrong way round                               |
|   |   | → The controller may be faulty  |
| 2. Oven heats up when the instrument switch is <b>OFF</b>     | → The SSR has failed "ON"                             | → Check for an accidental wiring fault that could have overloaded the SSR           |

**7.0 CIRCUIT DIAGRAMS**

**7.1 Single Phase (overtemperature control: none or hydraulic thermostat)**

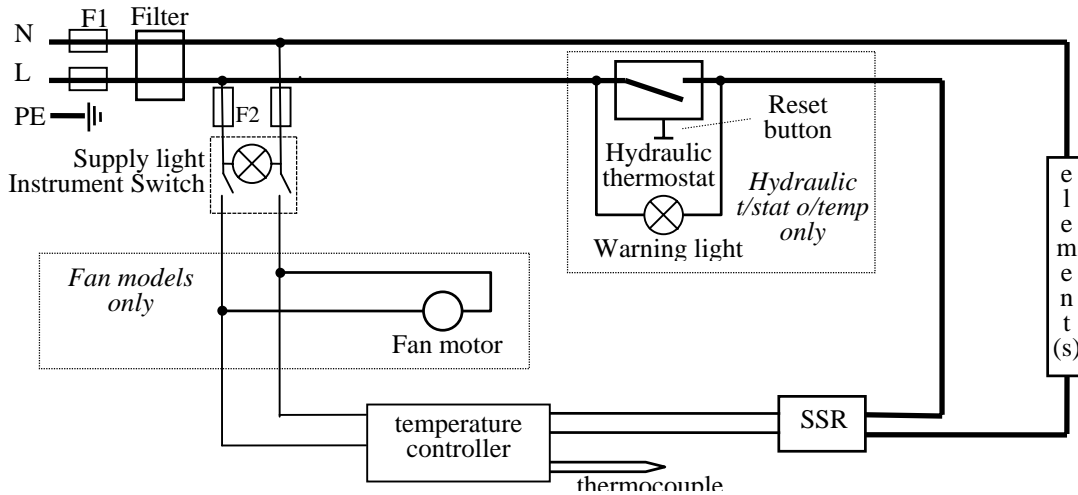

*Note on Hydraulic Thermostat.* When used over 16 Amps or in a 2- or 3-phase model, the oven is fitted with a contactor, with the hydraulic thermostat in the coil circuit – similar to 7.2.

**7.2 Single Phase (overtemperature control: digital)**

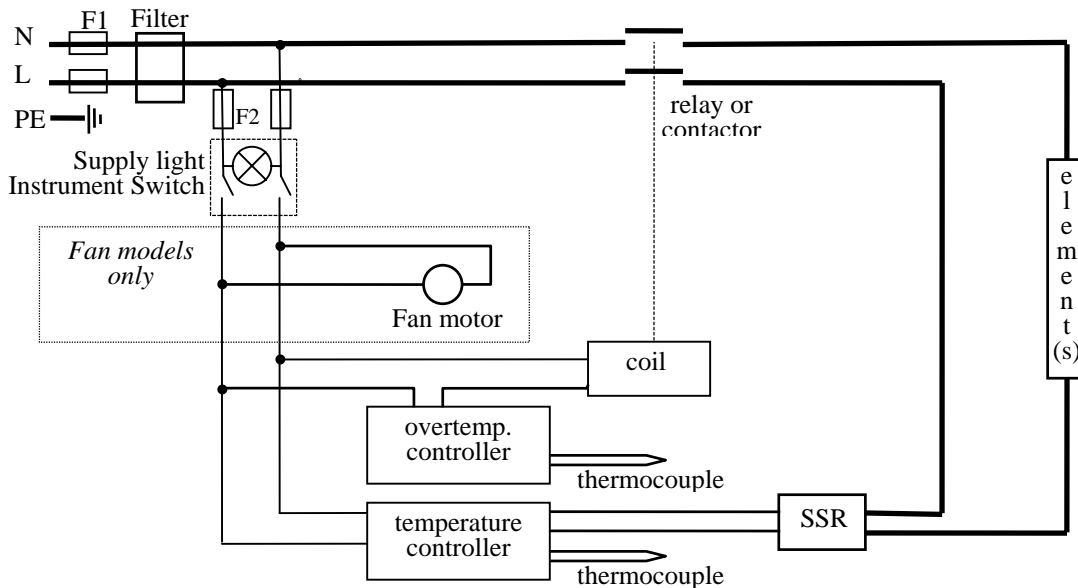

**7.3 Two-phase with Neutral**

As 3-phase with neutral (7.4), but with phase L3 not present, and with two SSRs and element circuits.

**7.4 Three Phase with Neutral**

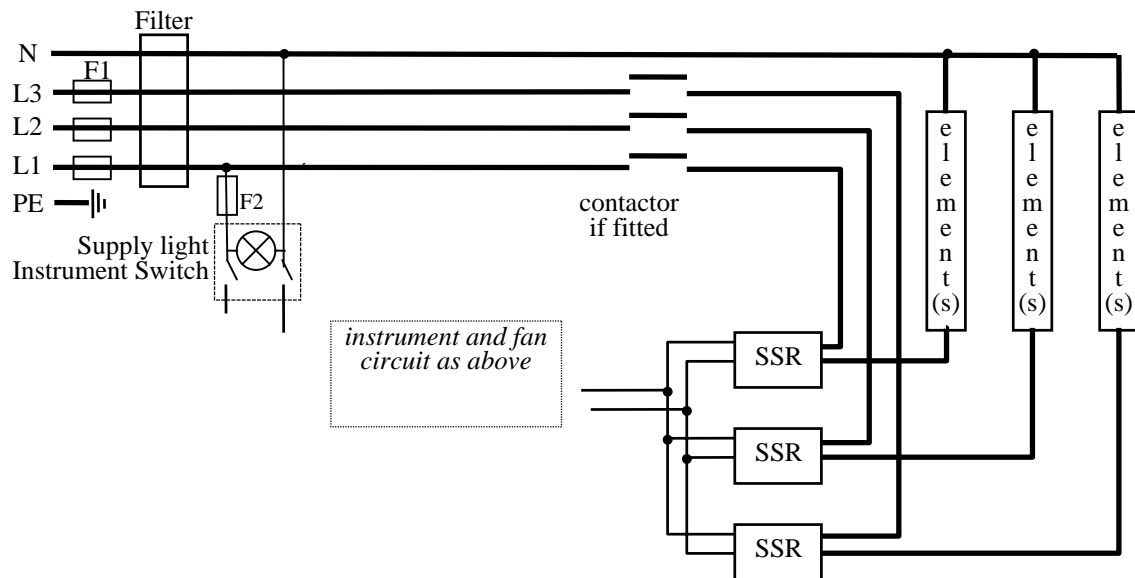

*Note on 3-phase. Depending on filter(s) fitted, there may be 3 separate neutral wires from the elements to the neutral supply.*

**7.5 Three Phase without Neutral (delta e.g. 208-240V)**

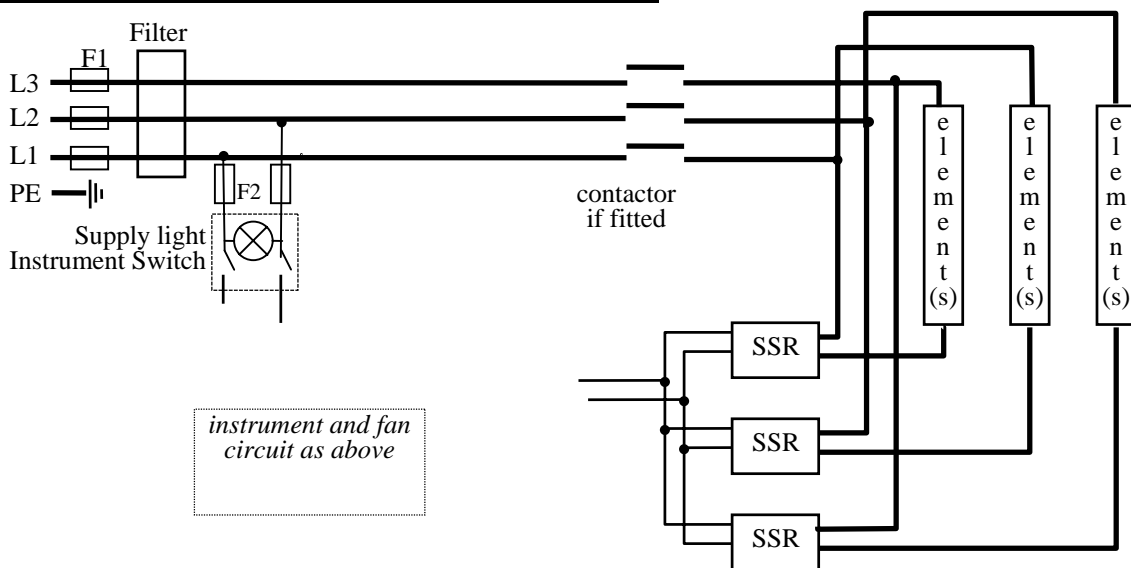

**7.6 Three phase without Neutral (star – e.g. 380-415V)**

The circuit is similar to 7.4, but the “neutral” ends of the elements are not connected to a neutral terminal block.

The control circuit contains an isolating transformer to reduce the control voltage to 240V or similar.

**7.7 Higher Voltages (e.g. 254V)**

The control circuit contains an isolating transformer to reduce the control voltage to 240V or similar.

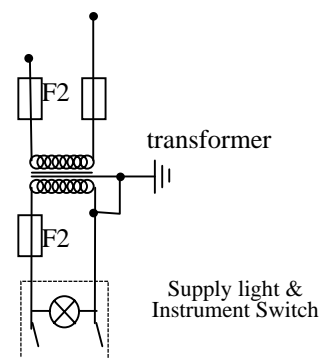

**7.8 Stoving & Curing**

The following addition is made to the circuit.

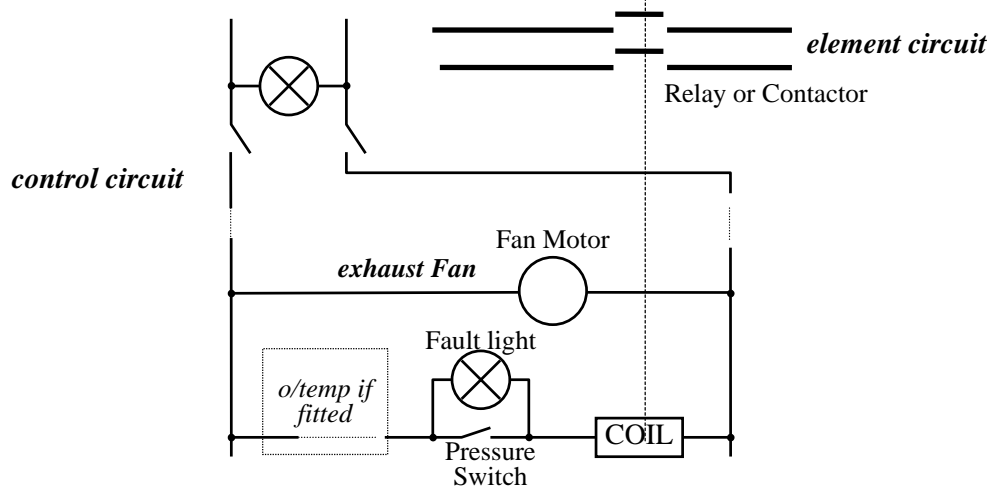

**7.9 Cooled Incubator (PIC models)**

The following addition is made to the circuit.

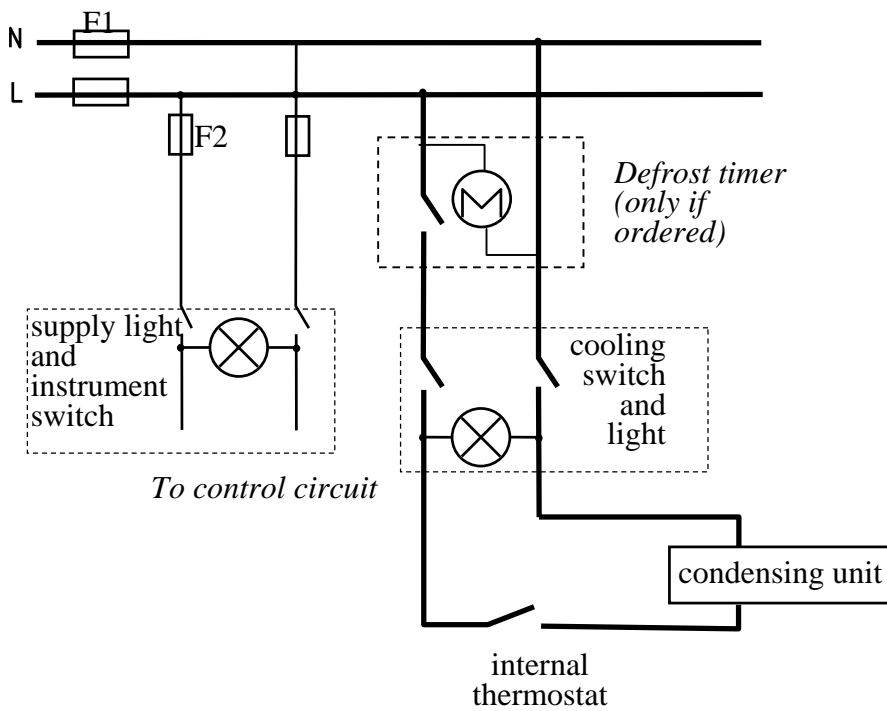

## 8.0 FUSES & POWER SETTINGS

### 8.1 Fuses

*F1-F2: Refer to the circuit diagrams.*

<i>F1</i>	Internal supply fuses	Fitted if supply cable fitted. Fitted on board to some types of EMC filter.	on-board and up to 16 Amps: 32mm x 6mm type F other: GEC Safeclip
<i>F2</i>	Auxiliary circuit fuses	Fitted on board to some types of EMC filter. May be omitted up to 25Amp/phase supply rating.	2 Amps glass type F On board: 20mm x 5mm Other: 32mm x 6mm
	<b>Customer fuses</b>	Required if no supply cable fitted. Recommended if cable fitted.	See rating label for amperage; see table below for fuse rating.

Model	phases	Volts	Supply Fuse	Volts	Supply Fuse	Control Fuse
PIN30, PIF30	1-phase	220-240	5A	110-120	5A	2A
PN30, PIC30	1-phase	220-240	5A	110-120	7A	2A
PF30	1-phase	220-240	5A	110-120	10A	2A
PIN60	1-phase	220-240	5A	110-120	5A	2A
PIF60	1-phase	220-240	5A	110-120	7A	2A
PN60, PIC60	1-phase	220-240	5A	110-120	10A	2A
PF60	1-phase	220-240	7A	110-120	12.5A	2A
PIN120, PIF120	1-phase	220-240	5A	110-120	7A	2A
PN120, PIC120	1-phase	220-240	7A	110-120	12.5A	2A
PF120	1-phase	220-240	10A	110-120	20A	2A
PIN200, PIF200	1-phase	220-240	5A	110-120	10A	2A
PIC200	1-phase	220-240	7A	110-120	15-16A	2A
PN200	1-phase	220-240	10A	110-120	20A	2A
PF200	1-phase	220-240	12.5A	110-120	25A	2A
PIF400	1-phase	220-240	10A			5A
PF400	1-phase	220-240	30-32A			5A
PF400	2-phase+N	380/220-415/240	15-16A			5A
PIF800	1-phase	220-240	20A			5A
PF800	1-phase	220-240	40A			5A
PF800	3-phase+N	380/220-415/240	15-16A			5A

208V models may have a higher fuse rating: check the rating label.

### 8.2 Power Settings

All models are designed for a power limit (OP.Hi) of 100% with the following exceptions to date:

- any model on 254V: 89%
- PN200 on 110V: 89%; on 120V: 75%
- PF120 on 208V: 89%
- PF200 on 120V: 90%

## 9.0 SPECIFICATIONS

*Carbolite reserves the right to change specifications without notice.*

### 9.1 Models Covered by this Manual

MODEL	Max. Temp. (°C)	Max. Power (kW)	Chamber Size (mm)			Approx. Capacity (l)	Net Weight (kg)
			H	W	D		
<i>Peak Range Incubators - no fan</i>							
PIN30	80°C	0.25	255	330	320	27	35
PIN60	80°C	0.68	350	390	420	57	49
PIN120	80°C	0.68	450	490	520	115	69
PIN200	80°C	1.0	700	590	520	215	98
<i>Peak Range Incubators - with fan</i>							
PIF30	80°C	0.25	300	290	320	28	35
PIF60	80°C	0.68	400	390	420	66	49
PIF120	80°C	0.68	500	490	520	127	69
PIF200	80°C	1.0	750	590	520	230	98
PIF400	80°C	2.0	1500	605	510	460	195
PIF800	80°C	4.0	1500	1200	510	910	380
<i>Peak Range Ovens - no fan</i>							
PN30	300°C	0.75	255	330	320	27	33
PN60	300°C	1.0	350	390	420	57	46
PN120	300°C	1.5	450	490	520	115	65
PN200	300°C	2.25	700	590	520	215	90
<i>Peak Range Ovens - with fan</i>							
PF30	300°C	1.0	300	290	320	28	33
PF60	300°C	1.5	400	390	420	66	46
PF120	300°C	2.0	500	490	520	127	65
PF200	300°C	2.7	750	590	520	230	90
PF400	250°C	6.0	1500	605	510	460	185
PF800	250°C	9.0	1500	1200	510	910	365
<i>Peak Range Cooled Incubators - with fan</i>							
PIC30	60°C	0.25	300	290	320	28	48
PIC60	60°C	0.68	400	390	420	66	77
PIC120	60°C	0.68	500	490	520	127	100
PIC200	60°C	1.0	750	590	520	230	131

### 9.2 Environment

The ovens contain electrical parts and should be stored and used in indoor conditions as follows:

temperature: 5°C - 40°C - (*note: incubators other than cooled incubators cannot maintain a low temperature unless the ambient temperature is also low*)

relative humidity: maximum 80% up to 31°C decreasing linearly to 50% at 40°C