



Installation, Operation & Maintenance Instructions

Annealing Ovens
TLD models

This manual is for the guidance of operators of the above Carbolite products and should be read before the oven is connected to the electricity supply.

CONTENTS

Section		page
1.0	Symbols & Warnings	1
2.0	Installation	3
3.0	Operating Instructions	4
4.0	Maintenance	6
5.0	Repairs & Replacements	7
6.0	Fault Analysis	9
7.0	Circuit Diagrams	10
8.0	Fuses & Power Settings	11
9.0	Specifications	12

Manuals are supplied separately for the temperature controller (and overtemperature controller when fitted).

Please read the controller manuals before operating the oven.

SYMBOLS & WARNINGS

1.1 Switches and Lights



Supply Light: when the oven is connected to the electrical supply the light in the adjacent switch glows

1.2 Warning Symbols

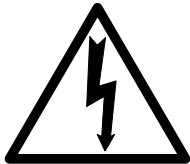

DANGER of electrical shock– read any warning printed by this symbol.



DANGER – hot surface. Read any warning printed by this symbol.
WARNING: all surfaces of an oven may be hot.



DANGER – read any warning printed by this symbol.

1.3 Introduction

Reproducible annealing of thermoluminescent dosimeters is essential to maintain constant sensitivity and low background readings.

Use of the Carbolite TLD Annealing Oven ensures that the best results are consistently obtained. The fan assisted air recirculating system eliminates the temperature gradients encountered in simple gravity convection ovens. The risk of errors arising due to non-reproducible annealing is greatly reduced by the automatic program controller.

The Carbolite annealing oven is supplied as a complete self contained unit. The front opening side hinged door gives access to the work chamber which is fitted with two shelves. The air recirculating fan draws air from the back of the chamber and passes it over the heating elements. The reheated air is then returned to the chamber on all four sides. The temperature programmer is conveniently located in the base of the equipment below the oven chamber.

2.0 **INSTALLATION**

2.1 **Unpacking & Handling**

Lift the unit by its base. Do not use the door or any other projecting cover or component to support the equipment when moving it. Use two people to carry the oven where possible. Remove any packing material from the inner chamber before use.

2.2 **Siting & Setting Up**

Place the oven on a level surface.

Ensure that there is free space around the oven. Ensure that any vents in the oven are not obscured. During the operation of the oven hot air is exhausted from the vent on the top of the oven while the cooling blower is in operation; there must be clearance of at least 500mm between the top of the oven and any surface which must be made of non-combustible material.

Ensure that the oven is placed in such a way that it can be quickly switched off or disconnected from the electrical supply - see below the top of the oven and the ceiling of the room. Always ensure that the vent on the top of the oven is free to open.

2.3 **Electrical Connections**

Connection by a qualified electrician is recommended.

The oven is manufactured for use on a single phase supply, which may be Live to Neutral non-reversible, Live to Neutral reversible or Live to Live.

Check the Oven rating label before connection. The supply voltage should agree with the voltage on the label, and the supply capacity should be sufficient for the amperage on the label.

The supply should be fused at the next size equal to or higher than the amperage on the label. A table of the most common fuse ratings is also given in section 8.1 of this manual. Where a supply cable is present there are internal supply fuses; customer fusing is preferred but not essential.

Oven with supply cable: either wire directly to an isolator or fit with a line plug.

Oven without supply cable: a permanent connection to a fused and isolated supply should be made to the internal terminals after temporary removal of the oven back panel.

Connection by line plug: the plug should be within reach of the operator, and should be quickly removable.

Connection to isolating switch: this should operate on both conductors and should be within reach of the operator.

The supply MUST incorporate an earth (ground).

CONNECTION DETAILS			<i>supply type</i>	
Supply	Terminal label	Cable colour	<i>Live-Neutral</i>	<i>Reversible or Live-Live</i>
<i>1-phase</i>	L	Brown	To live	to either power conductor
	N	Blue	To neutral	to the other power conductor
	PE	Green/Yellow	To earth (ground)	to earth (ground)

3.0 OPERATING INSTRUCTIONS

3.1 Operating Program

The program consists of the stages shown in the graph below. The rates of temperature rise, dwell temperature and dwell times are all adjustable by the user. The general format of the program is installed at the manufacturing stage, with initial values as shown in the table below.

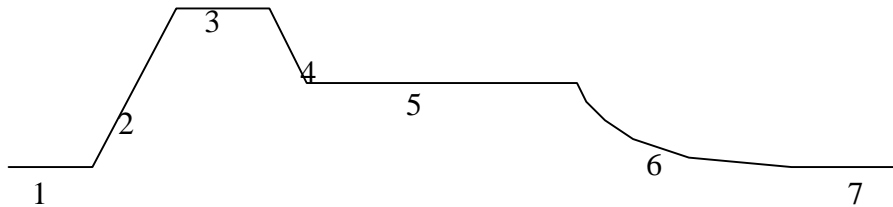

	function	initial setting	program	
1	Start.			
2	Heat at a controlled rate.	heat up at 480°C/hour to 300°C	SEG.n 1 tGt rAtE	rmP.r 300°C 8°C per min
3	Dwell for a preset period.	dwell at 300°C for 1 hour	SEG.n 2	dweLL 1 hour
4	Cool at a controlled rate.	Cool to 80°C assisted by inlet blower	SEG.n 3 tGt rAtE	rmP.r 80°C 20°C per min
5	Dwell for a preset period.	80°C for 12 hours	SEG.n 4	dweLL 12 hours
6	Cool naturally to room temperature.		SEG.n 5	SteP 0°C
7	Finish.		SEG.n 6	End

This program causes the oven to heat up at 480°C per hour to a temperature of 300°C. The temperature remains at 300°C for 1 hour. At the end of the 1 hour the setpoint changes to 80°C and the oven cools down as quickly as possible to this temperature. The rate of cooling is quite fast because of the air inlet blower which is incorporated in the oven. When the chamber temperature reaches 80°C the second dwell period starts and the oven remains at 80°C for 12 hours. At the end of 12 hours the heaters are switched off and the oven cools naturally to room temperature.

3.2 Controls

The instructions for operating the temperature controller are given in a separate manual.

The oven is fitted with a combined Supply light and Instrument switch. The light is on whenever the oven is connected to the supply. The switch cuts off power to the controller(s).

The circulation fan operates when the instrument switch is switched on.

Connect the oven to the electrical supply. The Supply light should glow .

Operate the instrument switch to activate the temperature programmer; the **O** position is off, the **I** position on. The programmer becomes illuminated and goes through a short test cycle.

Adjust the temperature – see the controller manual.

Overtemperature Option: If the overtemperature controller has not yet been set as required, set it and activate it according to the instructions in the appropriate manual.

The oven starts to heat up according to the set program.

To switch the oven off, set the Instrument switch to **O**. If the oven is to be left off, isolate it from the electrical supply.

3.3 Overtemperature Control (if fitted)

The overtemperature controller should typically be set at 15°C above the top temperature used by the main programmer. If an overtemperature condition occurs, always investigate the possibility that the main control system has failed.

An overtemperature condition always cuts off power to the heating elements. It is indicated by a light in the overtemperature controller flashing. To reset the condition, either allow the oven to cool, or increase the overtemperature setting, then follow the instructions in the manual supplied.

4.0 MAINTENANCE

4.1 General Maintenance

No routine maintenance is required other than the occasional replacement of consumable items.

The oven outer surface may be cleaned with a damp cloth. Do not allow water to enter the interior of the case. Do not clean with organic solvents.

The fan motors are sealed for life; no lubrication is required.

4.2 Calibration

After prolonged use the controller and/or thermocouple could require recalibration. This would be important for processes which require accurate temperature readings. A quick check using an independent thermocouple and temperature indicator should be made from time to time to determine whether full calibration is required.

For a quick check of the temperature shown by the control thermocouple and oven controller, a portable temperature indicator and probe thermocouple may be used.

Depending on the controller, the controller manual may contain calibration instructions.

4.3 After Sales Service

Carbolite's service division (Thermal Engineering Services) has a team of Service Engineers capable of repair, calibration and preventive maintenance of furnace and oven products at our customers' premises throughout the world. We also sell spares by mail order. A telephone call or fax often enables a fault to be diagnosed and the necessary spare part despatched.

Each furnace has its own record card at Carbolite. In all correspondence please quote the serial number, model type and voltage given on the rating label of the furnace. The serial number and model type are also given on the front of this booklet when supplied with a furnace.

To contact Thermal Engineering Services or Carbolite see the back page of this manual.

4.4 Recommended Spares Kits

Carbolite can supply individual spares, or a kit of the items most likely to be required. Ordering a kit in advance can save time in the event of a breakdown. Please enquire for information on a suitable kit for this model.

When ordering spares please quote the model details as requested above.

4.5 Power Adjustment

The control system incorporates electronic power limiting, but in these models the power limit is set to 100% and the power limit parameter OP.Hi may be inaccessible to the operator.

Rarely, in the case of uncommon voltages (e.g. outside the range 220-240V or the 3-phase equivalent), the power limit parameter may be set to a value other than 100%. Do not increase the value to 100%. See section 8.2 for details of any power limit settings.

Occasionally the power limit is set to zero to permit demonstration of the controls without the heating elements taking power. In this case the power limit is accessible to the operator and may be reset to its standard value, usually 100: see section 8.2.

5.0 REPAIRS & REPLACEMENTS

5.1 Safety Warning – Disconnection from Supply

Always ensure that the oven is disconnected from the supply before repair work is carried out.



5.2 Safety Warning - Refractory Fibrous Insulation

This oven contains refractory fibres in its thermal insulation. These materials may be in the form of fibre blanket or felt, vacuum formed board or shapes, mineral wool slab or loose fill fibre.



Normal use of the oven does not result in any significant level of airborne dust from these materials, but much higher levels may be encountered during maintenance or repair.

Whilst there is no evidence of any long term health hazards, we strongly recommend that safety precautions are taken whenever the materials are handled.

Exposure to dust from fibre which has been used at high temperatures may cause respiratory disease.

When handling fibre always use an approved mask, eye protection, gloves and long sleeved clothing.

Avoid breaking up waste material. Dispose of waste fibre in sealed containers.

After handling rinse exposed skin with water before washing gently with soap (not detergent). Wash work clothing separately.

Before commencing any major repairs we recommend reference to the European Ceramic Fibre Industry Association Bulletin No. 11 and the UK Health and Safety Executive Guidance Note EH46.

We can provide further information on request. Alternatively our service division can quote for any repairs to be carried out at your premises or ours.

5.3 Panel Removal



Disconnect the oven from the electrical supply.

To replace components (except controller), remove the front panel. Depending on the component, it may be necessary to remove an internal panel. If in doubt, please consult Carbolite's technical department.

5.4 Temperature Controller Replacement

Ease apart the two lugs at the side; grip the instrument and withdraw it from its sleeve; push in the replacement.

5.5 Solid-state Relay Replacement

Remove the front panel. Make a note how the wires are connected to the solid state relay, and disconnect them.

Remove the solid state relay from the aluminium plate.

Replace and reconnect the solid state relay ensuring that the heat-conducting thermal pad is sandwiched between the relay and the base panel or aluminium plate. Alternatively a thin layer of white, heat-conducting silicon paste may be applied between the new relay and the plate.

The new solid state relay contains a built-in MOV which protects it from short periods of excess voltage. If the old relay had a separate disc-shaped "MOV" connected between the high voltage terminals of the old relay, discard the old MOV.

Replace the removed panel.

5.6 Thermocouple Replacement

Remove the front panel and the internal cover as necessary.

Make a note of the thermocouple connections, and how the thermocouple is placed and fixed. Colour codings are:

<i>negative</i>	<i>positive (type K)</i>
white	green

Disconnect the thermocouple from its controller terminals or terminal block.

Re-assemble with the new thermocouple observing the colour coding.

5.7 Element Replacement

Remove front panel and the internal cover as necessary and locate the element terminals.

Disconnect the wires from the element terminals. Remove any starlock washers - these may need to be cut with wire cutters. Remove any clips holding the element inside the chamber, and withdraw the element.

Reverse the procedure with the new element.

Run the oven at a low temperature and check that it is controlling properly, to find out whether the element failure was caused by a fault in the control circuit.

5.8 Fuse Replacement

Fuses are accessed by removal of the panel near the cable entry point.

Depending on the model, supply fuses and control circuit fuses may be mounted in their own holders, or may be on a circuit board which contains an EMC filter. The fuses are marked with their ratings.

Take care not to disconnect the wires leading from the EMC filter without first recording their positions: they must be reconnected to the correct terminals.

6.0 FAULT ANALYSIS

A. Oven Does Not Heat Up

- | | | |
|--|--|--|
| 1. The SUPPLY light is OFF | → No power from the supply | → Check the fuses in the supply line |
| 2. The SUPPLY light is ON | → The controller shows a very high temperature or a code such as S.br | → The thermocouple has broken or has a wiring fault |
| | → The controller shows a low temperature | → The SSR could be failing to switch on due to internal failure, faulty logic wiring from the controller, or faulty controller |
| | → There are no lights glowing on the controller | → The controller may be faulty or not receiving a supply due to a faulty switch or a wiring fault |

B. Oven Overheats

- | | | |
|---|---|---|
| 1. Oven only heats up when the instrument switch is ON | → The controller shows a very high temperature | → The controller is faulty |
| | → The controller shows a low temperature | → The thermocouple may have been shorted out or may have been moved out of the oven |
| | | → The thermocouple may be mounted the wrong way round |
| | | → The controller may be faulty |
| 2. Oven heats up when the instrument switch is OFF | → The SSR has failed "ON" | → Check for an accidental wiring fault which could have overloaded the SSR |

7.0 CIRCUIT DIAGRAMS

7.1 Single Phase

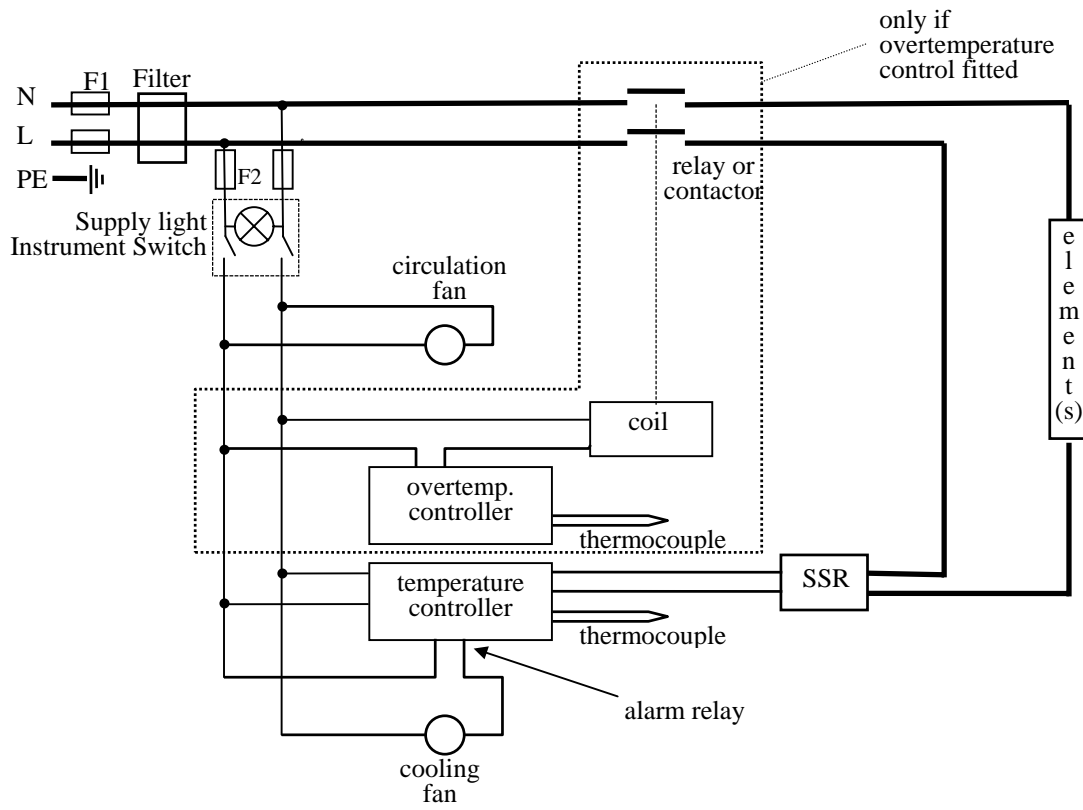

8.0 FUSES & POWER SETTINGS

8.1 Fuses

F1-F2: Refer to the circuit diagrams.

<i>F1</i>	Internal supply fuses	Fitted if supply cable fitted. Fitted on board to some types of EMC filter.	on-board and up to 16 Amps: 32mm x 6mm type F other: GEC Safeclip
<i>F2</i>	Auxiliary circuit fuses	Fitted on board to some types of EMC filter. May be omitted up to 25Amp/phase supply rating.	2 Amps glass type F On board: 20mm x 5mm Other: 32mm x 6mm
	Customer fuses	Required if no supply cable fitted. Recommended if cable fitted.	See rating label for amperage; see table below for fuse rating.

F1 - supply fuses :	TLD/3 (220-240V)	5 Amps	TLD/28 (220-240V)	10 Amps
F2 - control fuses:	TLD/3	2 Amps	TLD/28	5 Amps

8.2 Power Settings

All models are designed for a power limit (OP.Hi) of 100%.

9.0 SPECIFICATIONS

Carbolite reserves the right to change specifications without notice.

9.1 Models Covered by this Manual

MODEL	Max. Temp. (°C)	Max. Power (kW)	Chamber Size (mm)			Approx. Capacity (l)	Net Weight (kg)
			H	W	D		
<i>Ovens for thermoluminescent dosimeters</i>							
TLD/3	400	1	150	150	150	3	
TLD/28	400	2.25	305	305	305	28	

9.2 Environment

The ovens contain electrical parts and should be stored and used in indoor conditions as follows:

temperature: 5°C - 40°C

relative humidity: maximum 80% up to 31°C decreasing linearly to 50% at 40°C