



Bronze High Lift Safety Valves - with Test Levers Screwed or Flanged Connections

Order Ref:

Standard:

G100-M-DN-X

Stainless Steel trim:

G100-SS-DN-X

DN = Size in mm

X = Spring Range (see Chart Over)

GRESSWELL G100 HIGH LIFT SAFETY VALVES

Side Outlet discharge with test lever. These valves are used with compressible media, mainly steam systems to prevent safe pressures being exceeded.

SIZE RANGE

mm	15	20	25	32	40	50
ins	1/2	3/4	1	1 1/4	1 1/2	2

PIPE CONNECTIONS

Male Inlet x Female Outlet.

Standard valves are threaded BS 21:1985 Rp Parallel. Alternative thread standards, i.e. taper or NPT are available upon request.

Flanged connections also available. Most flange standards can be accommodated, e.g. ANSI, BS4504 - please specify requirements.

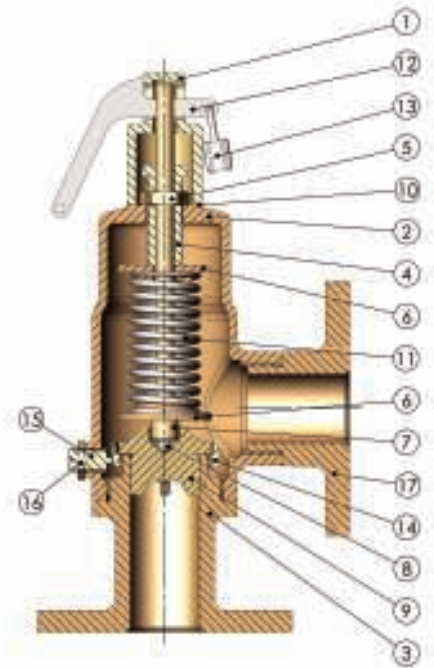

STANDARD SPECIFICATION

No.	Component	Material	No.	Component	Material
1	Dome Top	Cu Alloy BS EN 12164 CW617N	9	Valve	Cu Alloy BS EN 12165 CW602N
2	Body	Cu Alloy BS EN 1982 CC491K	10	Label	Metallised Polymer
3	Base	Cu Alloy BS EN 1982 CC491K	11	Spring	St. Steel BS2056 302 S26
3SS	St. St. Base	ASTM A 351/A 351M CF8M	12	Easing Lever	Stainless Steel
3FL	Inlet Flange	Cu Alloy BS EN 1982 CC491K	13	Padlock	Stainless Steel
4	Adjusting Screw	Cu Alloy BS EN 12164 CW641N	14	Blowdown Ring	Cu Alloy BS EN 1982 CC491K
5	Lock Nut	Cu Alloy BS EN 12164 CW641N	15	Locking Screw	Cu Alloy BS EN 12164 CW641N
6	Spring Plate	Cu Alloy BS EN 12164 CW721R	16	Lock Screw Nut	Cu Alloy BS EN 12164 CW641N
7	Spindle	Cu Alloy BS EN 12164 CW721R	17	Outlet Flange	Cu Alloy BS EN 1982 CC491K
8	Ball	St. Steel AISA 440c			

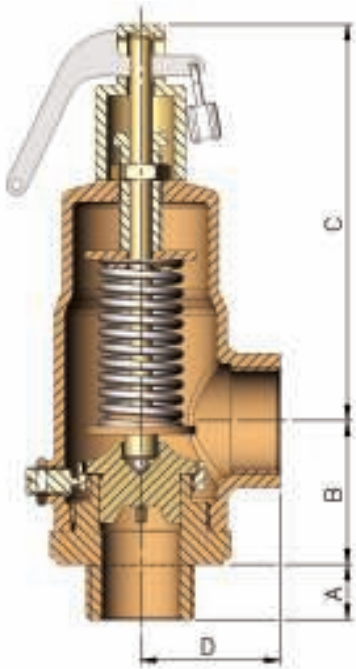

FEATURES & BENEFITS

Gresswell Valves are quality assurance approved to BS EN ISO 9001: 2000. Certificate No. 0910407.

Full Cat IV PED approval.

The G100 range of valves are ideal for handling compressible material but it must be noted... **they are not suitable for liquids.**

Clear operating and maintenance instructions are supplied with each despatch.

Generally in accordance with BS6759 Parts 1 & 2.

See leaflet Ref: DC G100 for Discharge Capacities.

TESTING

All Gresswell Relief Valves are given a hydraulic seat tightness test before leaving the factory and the adjustment range is clearly marked.

All valves are supplied pre-set.

Flanged valves are pressure tested to ensure soundness of joints.

Special tests or witness testing can be arranged at extra cost.

DIMENSION CHART

Size	A	B	C	D	Weight (kg)
DN15	16	35	89	33	0.6
DN20	16	36	98	40	0.8
DN25	17	47	114	48	1.6
DN32	22	56	154	54	2.2
DN40	24	57	154	57	3
DN50	30	68	163	73	4

All dimensions in millimetres (mm)

Flange dimensions (available upon request) vary according to specification

SPRING/PRESSURE RANGES at up to 225°C (437°F)

Type	Colour Code	Bar.g	p.s.i.g
A	Red	0.2 - 0.50	3 - 7
B	Blue	0.50 - 0.80	7 - 12
C	Green	0.80 - 1.4	12 - 20
D	Yellow	1.40 - 2.40	20 - 35
E	White	2.40 - 4.10	35 - 60
F	Black	4.10 - 5.90	60 - 85
G	Brown	5.90 - 8.60	85 - 125
H	Purple	8.60 - 12.10	125 - 175
J	Grey	12.10 - 15.50	175 - 225
K	Orange	15.50 - 19.0	225 - 275
L	Red & Black	19.0 - 21.0	275 - 300



Thank you for reading this data sheet.

For pricing or for further information, please contact us at our UK Office, using the details below.



UK Office

Keison Products,

P.O. Box 2124, Chelmsford, Essex, CM1 3UP, England.

Tel: +44 (0)1245 600560

Fax: +44 (0)1245 600030

Email: sales@keison.co.uk

Please note - Product designs and specifications are subject to change without notice. The user is responsible for determining the suitability of this product.