

FUNCTIONAL DESCRIPTION

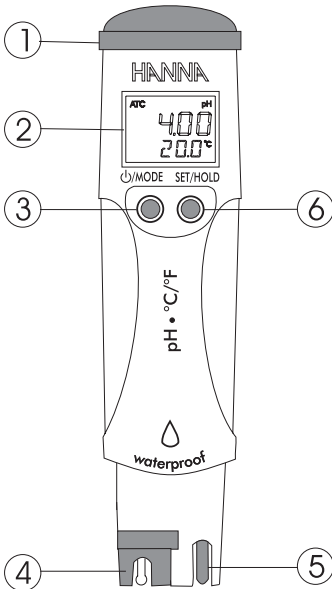

1. Battery compartment
2. Liquid Crystal Display (LCD)
3. ON/OFF/MODE button
4. HI 73127 pH electrode
5. Temperature sensor
6. SET/HOLD button

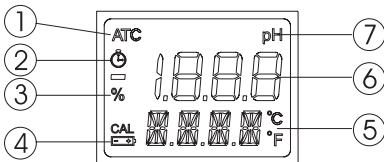

1. ATC (Automatic Temperature Compensation) indicator
2. Stability indicator
3. Battery life percentage indicator
4. Low battery indicator
5. Secondary display
6. Primary display
7. Measuring unit for primary display

CE DECLARATION OF CONFORMITY

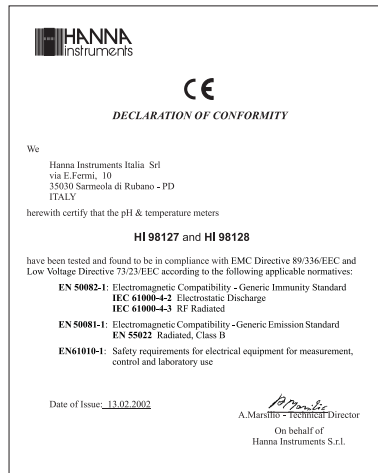

Recommendations for Users

Before using this product, make sure that it is entirely suitable for the environment in which it is used.

The glass bulb at the end of the electrode is sensitive to electrostatic discharges. Avoid touching the glass bulb at all times.

Any variation introduced by the user to the supplied equipment may degrade the instrument's EMC performance.

To avoid electrical shock, do not use this instrument when voltages at the measurement surface exceed 24 Vac or 60 Vdc. To avoid damages or burns, do not perform any measurement in microwave ovens.

ACCESSORIES

HI 73127	Replaceable pH electrode
HI 73128	Electrode removal tool
HI 70004P	pH 4.01 solution, 20 mL sachet (25 pcs)
HI 70006P	pH 6.86 solution, 20 mL sachet (25 pcs)
HI 70007P	pH 7.01 solution, 20 mL sachet (25 pcs)
HI 70009P	pH 9.18 solution, 20 mL sachet (25 pcs)
HI 70010P	pH 10.01 solution, 20 mL sachet (25 pcs)
HI 77400P	pH 4 & 7 solutions, 20 mL sachet (5 each)
HI 7004M	pH 4.01 solution, 230 mL bottle
HI 7006M	pH 6.86 solution, 230 mL bottle
HI 7007M	pH 7.01 solution, 230 mL bottle
HI 7009M	pH 9.18 solution, 230 mL bottle
HI 7010M	pH 10.01 solution, 230 mL bottle
HI 7061M	Electrode cleaning solution, 230 mL bottle
HI 70300M	Electrode storage solution, 230 mL bottle

SPECIFICATIONS

Range	-2.0 to 16.0 pH (HI 98127)
	-2.00 to 16.00 pH (HI 98128)
	-5.0 to 60.0°C / 23.0 to 140.0°F
Resolution	0.1 pH (HI 98127)
	0.01 pH (HI 98128)
	0.1°C / 0.1°F
Accuracy	±0.1 pH (HI 98127)
	±0.05 pH (HI 98128)
	±0.5°C / ±1°F
Typical EMC Deviation	±0.1 pH (HI 98127) ±0.02 pH (HI 98128) ±0.3°C / ±0.6°F
Temp. Compensation	Automatic
Environment	-5 to 50°C (23 to 122°F); RH 100%
Calibration	1 or 2 points with 2 sets of memorized buffers (pH 4.01/7.01/10.01 or 4.01/6.86/9.18)
Electrode	HI 73127 pH electrode (included)
Battery	4 x 1.5V with BEPS / approx. 300 hours
Auto-off	after 8 minutes of non-use
Dimensions	163 x 40 x 26 mm (6.4 x 1.6 x 1.0")
Weight	100 g (3.5 oz)

OPERATIONAL GUIDE

To turn the meter on and check the battery status

Press and hold the ϕ /MODE button until the LCD lights up. All the used segments on the LCD will be visible for 1 second (or as long as the button is pressed), followed by the percent indication of the remaining battery life (E.g. % 100 BATT).

Taking measurements

Submerge the electrode in the solution to be tested while stirring it gently. The measurements should be taken when the stability symbol \square on the top left of the LCD disappears.

The pH value automatically compensated for temperature is shown on the primary LCD while the secondary LCD shows the temperature of the sample.

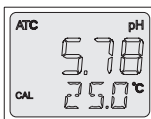

To freeze the display

While in measurement mode, press the SET/HOLD button. HOLD appears on the secondary display and the reading will be frozen on the LCD (E.g. pH 5.78 HOLD).

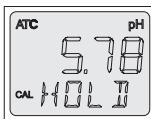

To turn the meter off

While in normal mode, press the ϕ /MODE button. OFF will appear on the secondary display. Release the button.

Notes:

- Before taking any measurements make sure the meter has been calibrated (CAL tag present on the LCD).
- If measurements are taken in different samples successively, rinse the probe thoroughly to eliminate cross-contamination; and after cleaning, rinse the probe with some of the sample to be measured.

CALIBRATION

For better accuracy, frequent calibration of the instrument is recommended. In addition, the instrument must be recalibrated whenever:

- The pH electrode is replaced.
- After testing aggressive chemicals.
- Where high accuracy is required.
- At least once a month.

Calibration procedure

From normal measuring mode, press and hold the ϕ /MODE button until OFF on the secondary LCD is replaced by CAL. Release the button. The LCD enters the calibration mode displaying "pH 7.01 USE" (or "pH 6.86 USE" if the NIST buffer set was selected).

After 1 second the meter activates the automatic buffer recognition feature. If a valid buffer is detected then its value is shown on the primary display and REC appears on the secondary LCD. If no valid buffer is detected, the meter keeps the USE indication active for 12 seconds, and then it replaces it with WRNG, indicating the sample being measured is not a valid buffer.

For a **single-point calibration** with buffers pH 4.01, 9.18 or 10.01, the meter automatically accepts the calibration when the reading is stable; the meter displays the accepted buffer, with the message "OK 1". After 1 second the meter automatically returns to the normal measuring mode.

If a single-point calibration with buffer pH 7.01 (or pH 6.86) is desired, then after the calibration point has been accepted the ϕ /MODE button must be pressed in order to return to normal mode. After the button is pressed, the meter shows "7.01" (or "6.86") - "OK 1" and, after 1 second, it automatically returns to the normal measuring mode.

Note: It is always recommended to carry out a two-point calibration for better accuracy.

For a **two-point calibration**, place the electrode in pH 7.01 (or pH 6.86) buffer. After the first calibration point has been accepted, the "pH 4.01 USE" message appears. The message is held for 12 seconds, unless a valid buffer is recognized. If no valid buffer is recognized, then the WRNG message is shown. If a valid buffer (pH 4.01, pH 10.01, or pH 9.18) is detected, then the meter completes the calibration procedure. When the buffer is accepted, the LCD shows the accepted value with the "OK 2" message, and then the meter returns to the normal measuring mode.

Note: When the calibration procedure is completed, the CAL tag is turned on.

To quit calibration and to reset to the default values

• After entering the calibration mode and before the first point is accepted, it is possible to quit the procedure and return to the last calibration data by pressing the ϕ /MODE button. The secondary LCD displays "ESC" for 1 second and the meter returns to the normal measuring mode.

• To reset to the default values and clear a previous calibration, press the SET/HOLD button after entering the calibration mode and before the first point is accepted. The secondary LCD displays "CLR" for 1 second, the meter resets to the default calibration and the CAL tag on the LCD disappears.

SETUP

Setup mode allows the selection of temperature unit and pH buffer set.

To enter the Setup mode, press the ϕ /MODE button until CAL on the secondary display is replaced by TEMP and the current temperature unit (E.g. TEMP °C). Then:

- **for °C/°F selection:** Use the SET/HOLD button. After the temperature unit has been selected, press the ϕ /MODE button to enter the buffer set selection mode; press the ϕ /MODE button twice to return to the normal measuring mode.
- **to change the calibration buffer set:** After setting the temperature unit, the meter will show the current buffer set: "pH 7.01 BUFF" (for 4.01/7.01/10.01) or "pH 6.86 BUFF" (for NIST 4.01/6.86/9.18). Change the set with the SET/HOLD button, then press ϕ /MODE to return to normal measuring mode.

pH ELECTRODE MAINTENANCE

• When not in use, rinse the electrode with water to minimize contamination and store it with a few drops of HI 70300 storage solution in the protective cap. **DO NOT USE DISTILLED OR DEIONIZED WATER FOR STORAGE PURPOSES.**

• If the electrode has been left dry, soak in storage solution for at least one hour to reactivate it.

• To prolong the life of the pH electrode, it is recommended to clean it monthly by immersing it in the HI 7061 cleaning solution for half an hour. Afterwards, rinse it thoroughly with tap water and recalibrate the meter.

- The pH electrode can be easily replaced by using the supplied tool (HI 73128). Insert the tool into the electrode cavity as shown below.

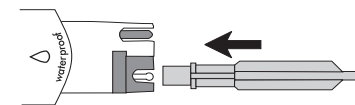

- Rotate the electrode counterclockwise.

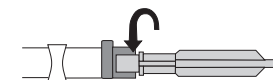

- Pull the electrode out by using the other side of the tool.

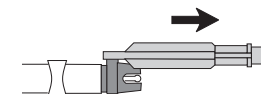

- Insert a new pH electrode following the above instructions in reverse order.

BATTERY REPLACEMENT

The meter displays the remaining battery percentage every time it is switched on. When the battery level is below 5%, the \square symbol on the bottom left of the LCD lights up to indicate a low battery condition. The batteries should be replaced soon. If the battery level is low enough to cause erroneous readings, the meter shows "0%" and the Battery Error Prevention System (BEPS) will automatically turn the meter off.

To change the batteries, remove the 4 screws located on the top of the meter.

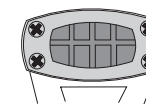

Once the top has been removed, carefully replace the 4 batteries located in the compartment while paying attention to their polarity.

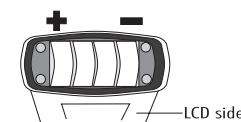

Replace the top, making sure that the gasket is properly seated in place, and tighten the screws to ensure a watertight seal.



Thank you for reading this data sheet.

For pricing or for further information, please contact us at our UK Office, using the details below.



UK Office

Keison Products,

P.O. Box 2124, Chelmsford, Essex, CM1 3UP, England.

Tel: +44 (0)330 088 0560

Fax: +44 (0)1245 808399

Email: sales@keison.co.uk

Please note - Product designs and specifications are subject to change without notice. The user is responsible for determining the suitability of this product.