

30 to 550°C

- 30°C to 550°C
- Emissivity > 0.995
- 65mm Diameter Cavity

The Gemini R 550 Portable Blackbody Calibration Source allows for calibration of noncontact infrared thermometers over the temperature range 30°C to 550°C.

It is suitable for use as a primary radiation source for infrared thermometers.

Laboratory performance and low uncertainty calibrations are ensured by the combination by high emissivity and excellent temperature uniformity.

The digital temperature controller allows the block temperature to be set to any value from 30°C to 550°C.

Traceability of the radiance temperature is established by a separate, built-in temperature indicator and included platinum resistance thermometer.

A three point traceable calibration certificate is included. UKAS calibration of the resistance thermometer is available, as is radiometric calibration.

Uniformity of the block is ensured by using distributed heating technology.

For the smallest of uncertainties the Gemini R may be used with Isotech ITS-90 Fixed Point Cells, Gallium 29.7646°C, Indium 156.5985°C, Tin 231.928°C and Zinc 419.527°C. The cells are provided with a certificate of metal purity.

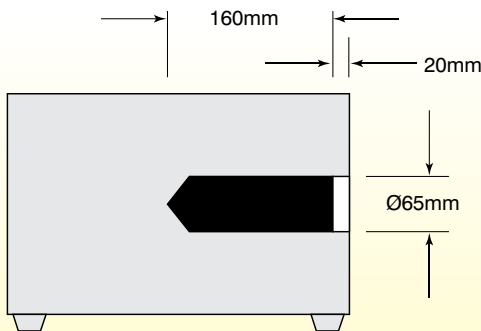

Gemini R

■ Test Report

The variation seen on the controller's temperature indication over a 5 minute period was $\pm 0.2^\circ\text{C}$. Similar variations were detected by a radiation thermometer looking into the cavity.

Using a portable radiation thermometer having a target diameter of 13mm, the 65mm target was surveyed.

Maximum temperature differences of $\pm 1^\circ\text{C}$ were found for set temperatures in the range 100°C to 500°C.

Temperatures along the inner 100mm of the 160mm long cavity were measured at 400°C and 500°C, using a hand held fibre-optic radiation probe. Maximum temperature differences of $\pm 4^\circ\text{C}$ were found.

The temperature, as shown on the controller, agrees with the cavity temperature as measured by a radiation thermometer, where calibration is traceable to National Standards, to within $\pm 2^\circ\text{C}$.

Blackbody Source Gemini R



Model	976
Temperature Range	30°C to 550.0°C
Emissivity	Greater than 0.995
Stability	$\pm 0.1^\circ\text{C}$
Display Resolution	0.01°C to 99.99; 0.1°C from 100 to 550
Heating Time	45 minutes
Aperture Diameter	65mm
Cavity Depth	160mm
PC Interface	included
Power	1000 Watts typical
Voltage	100-130 or 208-240 Vac 50/60Hz
Dimensions	H 310mm W 265mm D 200mm
Weight	10kg

Options

Fixed Point Cell	
Gallium Hockey Puck Cell	431-03-00
Indium Hockey Puck Cell	976-05-00A
Tin Hockey Puck Cell	976-05-00B
Zinc Hockey Puck Cell	976-05-00C
Orifice Plates 10, 20, 30, 40, 50mm (Restricts Cavity Aperture)	976-01-05
Carrying Case	931-22-64

How To Order

Model 976 Gemini R
State Supply Voltage
Please state any special calibration requirement



Thank you for reading this data sheet.

For pricing or for further information, please contact us at our UK Office, using the details below.



UK Office

Keison Products,

P.O. Box 2124, Chelmsford, Essex, CM1 3UP, England.

Tel: +44 (0)1245 600560

Fax: +44 (0)1245 600030

Email: sales@keison.co.uk

Please note - Product designs and specifications are subject to change without notice. The user is responsible for determining the suitability of this product.