

**MODEL 3345
ION METER
OPERATING MANUAL**

MODEL 3345 ION METER MANUAL

SECTION 1	INTRODUCTION	
	Description	1.1
	Specification	1.2
SECTION 2	INSTALLATION	
	Unpacking	2.1
	Installation	2.2
	Displays	2.3
	Controls	2.4
	Inputs/Outputs	2.5
SECTION 3	OPERATION	
	Menu Options	3.1
	Common Menu Options	3.2
	Using the unit with 2 sensors	3.3
	Operating the unit with only one display	3.4
	Endpoint detection	3.5
	pH MODE	
	Setting up parameters	3.6
	Entering pH Buffer Values	3.7
	pH Calibration - Automatic	3.8
	pH Calibration - Manual	3.9
	Error Codes	3.10
	Good Practice Guidelines	3.11
	mV MODE	
	Setting up parameters	3.12
	Temperature Measurement	3.13
	ION ANALYSIS	
	Ion Selective Measurements	3.14
	Good Practice Guidelines	3.15
	Concentration Mode	3.16
	Calibration	3.17
	Entering Cal Buffer Values	3.18
	Incremental Methods	3.19
	Known Addition/Subtraction	3.20
	Multiple Sample Addition/Subtraction	3.21
	Operating the Instrument with Optional Stirrer	3.22
	Datalogging	3.23

SECTION 4

MAINTENANCE

General	4.1
Cleaning/Re-conditioning of Glass Electrodes	4.2
Ion Selective Electrodes	4.3

SECTION 5

OPTIONAL ACCESSORIES

SECTION 6

INTERFACING

GLOSSARY OF TERMS

SECTION 1

INTRODUCTION

1.1 INSTRUMENT DESCRIPTION

The Model 3345 Ion Meter is a highly sophisticated product offering a host of valuable features, but retaining simplicity of operation.

The structured menus allow easy access to features with single key strokes. On-line help is provided to explain instrument functions and provide diagnostic information.

Important measurement features include the ability to operate both channels completely independently, simultaneous display of readings and temperature on both channels, and independent indication of stable readings. Details of the last calibration for each sensor are provided and all logged results and calibration routines are date and time stamped, thus satisfying the requirements of Good Laboratory Practice (GLP) quality assurance protocols.

The units will store up to 100 readings which can subsequently be recalled onto the instrument display or downloaded to a printer or PC via the bi-directional RS232 link. User programmable options include the ability to print out current readings or prompt calibration at pre-determined intervals and the setting of alarm points which are activated when the measured parameters will fall outside the preset limits.

The Model 3345 offers additional flexibility with two additional modes of ion analysis - Known addition/subtraction mode for the determination of ion concentration closer to the lower detection limit of the electrode, and multiple Sample addition/subtraction allowing measurement in dense and concentrated matrices.

1.2 INSTRUMENT SPECIFICATIONS

pH	
Range	-2 to 19.999pH
Resolution	0.1/0.01/0.001pH
Accuracy	±0.003pH
mV	
Range	-1999.9 to 1999.9mV
Resolution	0.1mV
Accuracy	±0.2mV
Concentration	
Range	1 x 10 ⁻⁹ to 9.99 x 10 ⁹
Units	Activity, ppm, %, mg/l, M or none
Resolution	3 significant digits
Accuracy	±0.003pX for monovalent ions
Input Impedance	>10 ¹³ Ohms
Number of Electrode Inputs	2
Temperature	
Range	-10 to 105°C / 14 to 221°F
Resolution	0.1°C / 1°F
Accuracy	±0.5°C / ±1°F
ATC Range	0 to 100°C / 32 to 212°F
Manual Temp. Comp. Range	0 to 100°C / 32 to 212°F
Number of Temperature Inputs	2
Auto Buffer Recognition	2, 4, 7, 9 and 10pH buffers with manual override facility
Pre-Programmed Ion Characteristics	NO ₃ ⁻ , ION ⁺ , ION ²⁺ , ION ⁻ , ION ²⁻ , H ⁺ , SCN ⁻ , Cu ²⁺ , S ²⁻ , CN ⁻ , I ⁻ , Br ⁻ , Cl ⁻ , Hg ²⁺ , Cd ²⁺ , Pb ²⁺ , F ⁻ , Ag ⁺ , CO ₃ ⁻ , Ba ²⁺ , NO ₂ ⁻ , ClO ₄ ⁻ , NH ₄ ⁺ , Ca ²⁺ , K ⁺
Calibration	1, 2 or 3 point pH / 1, 2, 3, 4 or 5 point Concentration
Outputs	Analog 1mV per digit Bi-directional RS232 Hi/Lo alarm outputs open collector 0.5A 50V max.
Datalogger	100 results
Clock	24 hour, hrs/min/sec or day of month, month and year/leap year corrected
Alarm Points	-2 to 19.999pH ±1999.9mV 1 x 10 ⁻⁹ to 9.99 x 10 ⁹
G.L.P.	Calibration reminder with an interval of 1 to 999 hours from last calibration Timed printout with an interval from 1 second to 1 day
Display	LCD Graphics
Power	Power Supply 9V a.c.
Size	275(l) x 240(w) x 150(d) mm
Weight	1.2Kg

SECTION 2

INSTALLATION

2.1 UNPACKING

Remove the Model 3345 from the packaging and ensure the items within the package are as ordered.

Any shortages or damage should be reported immediately to the Manufacturer or your local Distributor.

**NOTE: Power Supply 021 033 is supplied with a moulded European plug. If this is not correct for your local supply it should be cut off and a suitable local connector fitted noting the colours of the internal conductors as follows:
Brown - Live Blue - Neutral**

2.2 INSTALLATION

LCD CONTRAST

The LCD contrast can be set at any time. The LCD contrast potentiometer is accessible through the rear panel adjacent to the power socket.

This adjustment should only need to be made on receipt of the instrument. After initial adjustment the instrument will automatically adjust the contrast depending on the temperature of the glass.



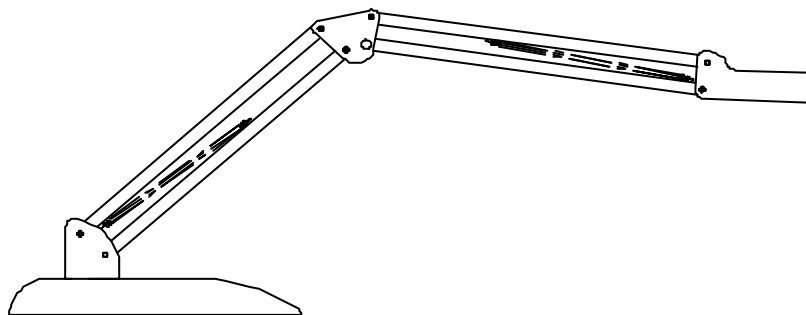

For instruments supplied with the swing arm electrode holder the following assembly instructions should be carried out:

1. Unpack the assembly and ensure the following items are present:
 - a) base block and b) swing arm. Assemble as illustrated. The moulded pivot is a tight push onto the pin.



2. Fit the pH electrode into the cut-out in the support block. The optional temperature probe, if supplied, should be placed into the small hole in the centre of the block. The cable(s) should be passed through the retaining clip on the holder and connected to the respective socket on the rear panel.

SETTING LANGUAGE

Move to the SETUP menu using the arrow keys and press the  key. Move the cursor to the INSTRUMENT SETUP mode using the  arrow key and press the  key. Move the cursor to the LANGUAGE menu and select the appropriate language by using the arrow keys. Once selected move to the EXIT option and press the  key. Pressing the  key a second time will return the instrument to the measurement mode.

2.3 DISPLAYS

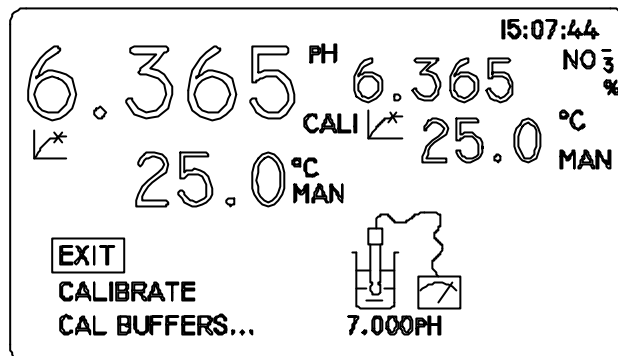

1. **PRIMARY DISPLAY** - sensor 1 display currently selected as primary reading. Units of measurement and calibration point will also be shown at the side of the main display.
2. **TEMPERATURE DISPLAY** - sensor 1 temperature display. Selected measurement unit and MAN to indicate manual temperature will be shown at the side of the display.
3. **ENDPOINT SYMBOL** - displayed once a stable reading is detected and is maintained until the input changes.
4. **ERROR MESSAGES** - displays error messages for sensor 1.
5. **MENU** - used for selection of modes of operation. The selected mode is reverse highlighted .
6. **ICONS** - used in pH and Ion modes to prompt steps of calibration and sample measurement.
7. **ERROR MESSAGES** - displays error messages for sensor 2.
8. **TEMP. DISPLAY** - sensor 2 temperature display. Selected measurement unit and MAN to indicate manual temperature will be shown at the side of the display.
9. **SECONDARY DISPLAY** - sensor 2 display currently selected as secondary reading. Units of measurement and calibration point will also be shown at the side of the main display.
10. **REAL TIME CLOCK** - giving continuous display of hours, minutes and seconds or day, month and year. All logged results are automatically time stamped.

2.4 CONTROLS

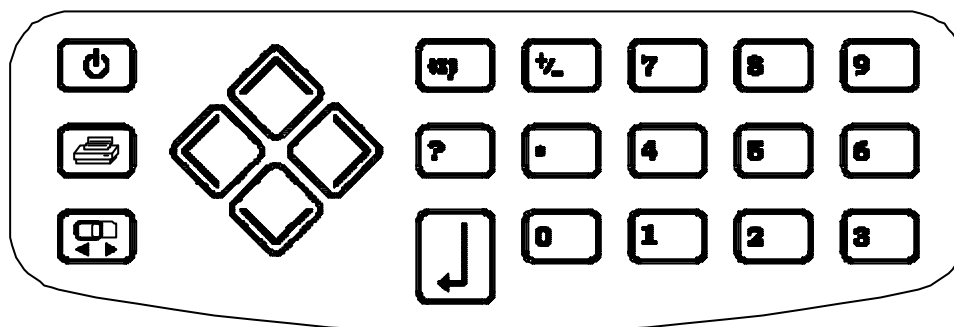

Switches the instrument on and to standby.



Print key. Provides a printout of the current readings with an incremental sample number depending on instrument operating mode. When pressed for the first time after a calibration, the print out will give calibration information. The incremental sample number will be reset after a calibration if auto cal print is set to on.



These keys are used to move around menus and for entering non-numerical functions.



Display select key. Used to toggle between primary and secondary displays.



Used to enter the exponential part of a value.
e.g. to enter 1.3×10^{-3} the key sequence is 1, ., 3, EXP, 3



Help key. Provides on-line help for menu options.



Used to select the displayed menu options and for entering parameters.



Used to change the sign of an entered number. It should be pressed after entering the value. To enter a negative exponent this key should be pressed after entering the exponent value - e.g. 1×10^{-3} - the key sequence is 1, EXP, 3, +/-



Numeric keys 0 - 9 are used to enter numeric data for measurement parameters, calibration data and limits.

2.5 INPUTS/OUTPUTS

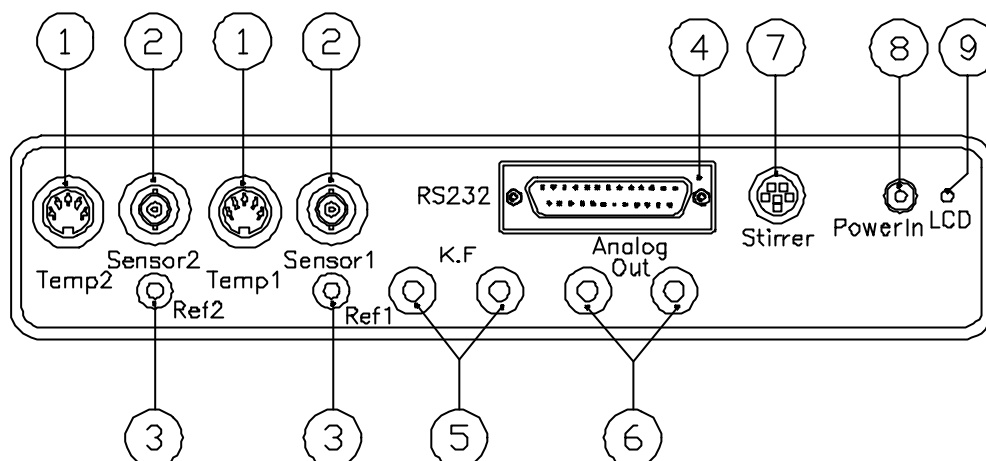

- | | | |
|----|----------------------|---|
| 1. | TEMP SOCKET | 5 pin DIN socket for the automatic temperature compensation (ATC) probe |
| 2. | pH SOCKET | BNC connection socket |
| 3. | REF SOCKET | 2mm pin connection socket for separate reference electrode |
| 4. | OUTPUT SOCKET | 25 way D socket for RS232 and alarm connections |
| 5. | KARL FISCHER | 2 x 4mm sockets. Polarised output. Karl Fischer titrations are enabled by the provision of a 10 μ A polarising current output |
| 6. | ANALOG OUT | 2 x 4mm sockets. Analog output proportional to primary display reading |
| 7. | STIRRER | Connection socket for optional stirrer |
| 8. | POWER IN | 2.1 x 5.5mm socket allowing the power supply to be connected to the unit |
| 9. | LCD | LCD contrast potentiometer |

SECTION 3

OPERATION

Connect the power supply appropriate to the supply being used to the instrument via the rear panel power socket. Connect the electrode(s), and ATC probes(s) if used, to the appropriate rear panel sockets.

When power is applied to the instrument the screen will show the mode last used prior to switch off. The measurement mode will be indicated by displayed units. To change the mode or exit, move to the required mode by using the arrow keys and then press  .

3.1 MENU OPTIONS

mV	CONC	STORE
CAL	RECALL	SETUP

mV	millivolt mode
CONC	concentration mode
STORE	used to store the displayed reading
CAL	calibration mode - the help key on this menu gives access to last calibration details
RECALL	recall mode for stored readings
SETUP	used to set up mode specific parameters, instrument and clock set up parameters

pH	CONC	STORE
ABS	RECALL	SETUP

pH	pH mode
CONC	concentration mode
STORE	used to store the displayed readings
ABS	absolute or relative millivolt mode selection
RECALL	recall mode for stored readings
SETUP	used to set up mode specific parameters, instrument and clock set up parameters

pH	mV	STORE
KNOWN ±		SAMPLE ±
CAL	RECALL	SETUP

pH	pH mode
mV	millivolt mode
STORE	used to store the displayed reading
KNOWN ±	known addition/subtraction mode
SAMPLE ±	sample addition/subtraction mode
CAL	calibration mode - the help key on this menu option gives access to last calibration details
RECALL	recall mode for stored readings
SETUP	used to set up mode specific parameters, instrument and clock set up parameters

3.2 COMMON MENU OPTIONS

NOTE: Any menu option suffixed with ... means access can be gained to a sub-menu below this level.

INSTRUMENT SETUP MENU

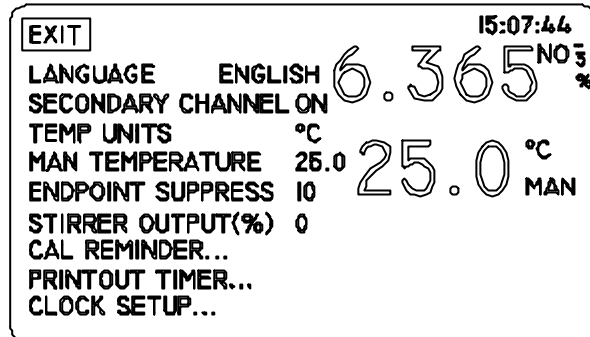

EXIT	menu escape key
LANGUAGE	used to set preferred language option
SECONDARY CHANNEL	allows the secondary display to be suppressed. A suppressed input will also be omitted from printed results
TEMP UNITS	used for selection of measurement in °C or °F
MAN TEMPERATURE	used to manually enter temperature values for both channels only if no ATC probe(s) are connected
ENDPOINT SUPPRESS	allows specific endpoint time to be entered for sample under test. If the sample is known to have a slow stabilisation point then the endpoint can be suppressed to the desired time
STIRRER OUTPUT (%)	used to set stirrer speed
CAL REMINDER...	allows the G.L.P. cal reminder functions to be set up
PRINTOUT TIMER...	allows the timer which prints readings at a preset interval to be set up
CLOCK SETUP...	used to select clock set up menu

SETTING LANGUAGE

Select LANGUAGE menu using the key and use arrow key or press key to highlight options. Select the required language using the keys and press to confirm.





SECONDARY CHANNEL

Select SECONDARY CHANNEL menu using the key and use arrow key or press to highlight options. Select ON or OFF option as required and press to confirm.





TEMP UNITS

Select TEMP UNITS menu using the key and use arrow key or press to highlight options. Select °C or °F option using the keys and press to confirm.





MAN. TEMPERATURE (default value 25°C)

Select MAN. TEMPERATURE menu using the  key and use  arrow key or press  to highlight options. Enter the new value using the numeric keypad and press  to confirm. If a mistake is made the  key can be used as a delete key, starting from the lowest digit and then re-enter the value using the numeric keys. To delete the whole entry keep pressing the key until a blank box appears. To default to the original value press the key again.

ENDPOINT SUPPRESS

Select the ENDPOINT SUPPRESS menu using the  key and use  or  key to highlight options. The value may be adjusted by selecting the required time, in units of seconds (1-999), using the numeric keys and then press  to confirm.

STIRRER OUTPUT (%)

Select the STIRRER OUTPUT (%) menu using the  key and use the  or  key to highlight the option. The value may be adjusted (0-100) using the numeric keys and then pressing  to confirm.

CAL REMINDER... (refer sub menu)

PRINTOUT TIMER... (refer sub menu)

CLOCK SETUP... (refer sub menu)

CAL REMINDER... SUB-MENU

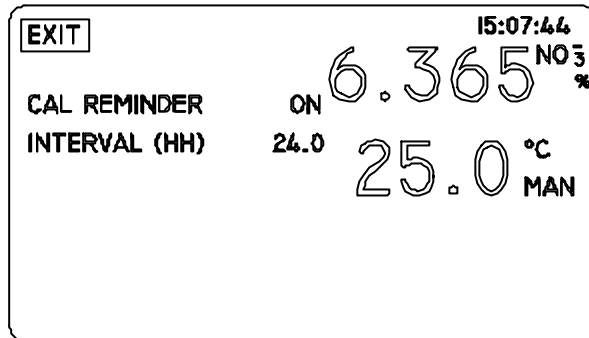

EXIT

menu escape key

CAL REMINDER





setting to ON will prompt re-calibration

setting to OFF will suppress the message





INTERVAL (HH)

allows interval to be set between 1 and 999 hours from the last calibration to prompt

CAL REMINDER

Select CAL REMINDER menu using the  key and use  arrow key or press  to highlight options. Select ON or OFF option as required and press  to confirm.

INTERVAL (HH)





Select the INTERVAL (HH) menu using the  key and use  or  key to highlight options. The value may be adjusted by selecting the required time, in units of 1/10 of an hour (6 minutes) using the numeric keys and then press  to confirm.

PRINTOUT TIMER SUB-MENU





EXIT		15:07:44
AUTO CAL PRINT	ON	6.365 NO ₃ %
CAL PRINT	SENSOR#1&2	25.0 °C
TIMED PRINT	OFF	MAN
INTERVAL	00:00:10	
START	00:00:00	
STOP	23:59:59	

EXIT	menu escape key
AUTO CAL PRINT	when set to ON this will automatically set sample number to no. 1 after calibration
CAL PRINT	specifies which sensor information will be included in a calibration printout
TIMED PRINT	allows the timed print facility to be turned on or off using the arrow keys
INTERVAL	can be set for hours, minutes and seconds. A printout will be initiated at that interval
START	start time set
STOP	stop time set





AUTO CAL PRINT

Select AUTO CAL PRINT menu using the  key and use  arrow key or press  to highlight options. Select ON or OFF option as required and press  to confirm.





CAL PRINT

Select CAL PRINT menu using the  key and use  key or  key to highlight options. Select Sensor 1, Sensor 2 or Sensors 1& 2 as required and press  to confirm.





TIMED PRINT

Select TIMED PRINT menu using the  key and use  arrow key or press  to highlight options. Select ON or OFF option as required and press  to confirm.





INTERVAL

Select the INTERVAL menu using the  key and use  or  key to highlight options. The value may be adjusted by selecting the required time, in units of hours:minutes:seconds using the numeric keys and then press  to confirm.

START

Select the START menu using the  key and use  or  key to highlight options. The value may be adjusted by selecting the required time, in units of hours:minutes:seconds using the numeric keys and then press  to confirm.

STOP

Select the STOP menu using the  key and use  or  key to highlight options. The value may be adjusted by selecting the required time, in units of hours:minutes:seconds using the numeric keys and then press  to confirm.

ALARM POINTS... SUB-MENU

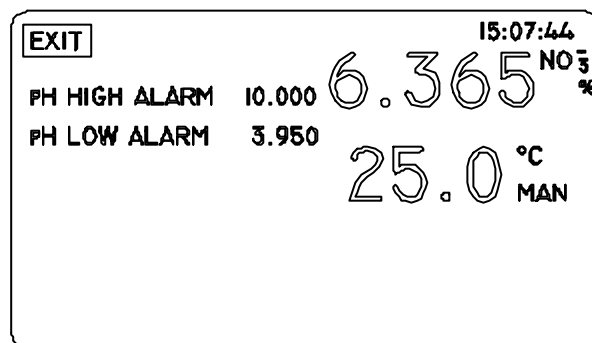

EXIT

menu escape key





XX HIGH ALARM

if the reading exceeds this value an alarm warning will appear on the display and the high output alarm will become active





XX LOW ALARM

if the reading exceeds this value an alarm warning will appear on the display and the low output alarm will become active

HIGH ALARM (default 19.999)

Select HIGH ALARM menu using the  key and use  or  key to highlight options. The value may be adjusted using the numeric keys and then pressing  to confirm.

LOW ALARM (default -2.000)



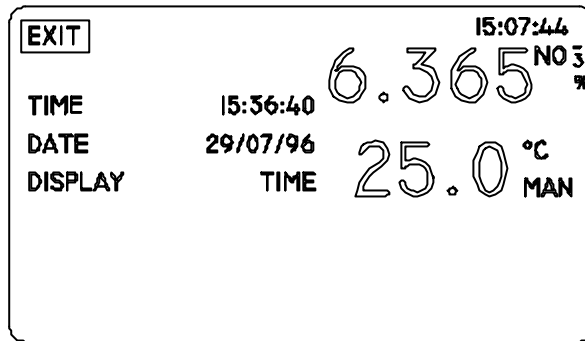

Select LOW ALARM menu using the  key and use  or  key to highlight options. The value may be adjusted using the numeric keys and then pressing  to confirm.

CLOCK SET UP SUB-MENU







EXIT	menu escape key
TIME	real time clock set up
DATE	date set up
DISPLAY	used to select display of time, date or none





TIME

Select the TIME menu using the  key and use  or  key to highlight options. The value may be adjusted by selecting the required time, in units of hours:minutes:seconds using the numeric keys and then press  to confirm.

DATE

Select the DATE menu using the  key and use  or  key to highlight options. The value may be adjusted by selecting the required time, in units of day:month:year using the numeric keys and then press  to confirm.

DISPLAY

Select DISPLAY menu using the  key and use  arrow key or press  to highlight options. Select time, date or none option as required and press  to confirm.

3.3 USING THE INSTRUMENT WITH 2 SENSORS

The instrument can be operated with either one or two sensors connected. Access to the individual displays can be made using the  key. Using this key will focus on one of the two sensors, thus providing a primary and secondary display (as shown below). The primary display will be shown over half of the screen, with the secondary display appearing in the opposite corner.

Access can now be gained to the parameters for the primary sensor. The menu options will now move over to the primary sensor and allow operation to take place as normal.

The secondary sensor will not be disabled automatically and will continue to measure.

3.4 OPERATING THE INSTRUMENT WITH 1 SENSOR

The instrument has the facility to disable the secondary display, allowing the the use of 1 sensor only. This can be achieved by entering the INSTRUMENT SET UP and setting the SECONDARY CHANNEL option to OFF using the  keys. The instrument will now only show the primary sensor details.

NOTE: This will be globally disabled.

3.5 ENDPOINT DETECTION

The endpoint detection facility can be altered to suit the requirements of individual tests being carried out on very slow reacting chemicals.

To change the endpoint detection enter the INSTRUMENT SETUP mode and highlight the ENDPOINT SUPPRESS option. The value may be adjusted by selecting the required time, in units of seconds (1-999), using the arrow keys and then press  .

The instrument will not show the endpoint symbol until the selected time has elapsed. The time entered is shared time on both channels i.e. it applies to both simultaneously.

3.6 pH MODE - SETTING UP PARAMETERS

pH SET UP MENU

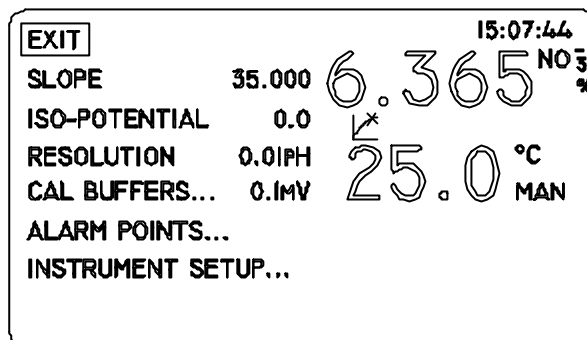

EXIT	menu escape key
SLOPE	electrode slope value between CAL1 and CAL2
ISO-POTENTIAL	allows the sensor iso-potential for the selected ion and channel to be changed. The iso-potential point is the sensor potential which does not change with temperature
RESOLUTION	allows the number of decimal places for the measured parameter shown on the display to be changed using the arrow keys
CAL BUFFERS...	allows the calibration buffers for the selected mode and sensor input to be viewed and changed
ALARM POINTS...	used to view and change alarm points for the selected mode and channel
INSTRUMENT SETUP...	used to select the next set up menu for instrument parameters

ELECTRODE SLOPE (1 point cal)

Enter pH SETUP menu and select SLOPE. Adjust the reading as required using the numeric keys and press



. The reading will default to 2 decimal places.

ISOPOTENTIAL POINT

Enter pH SETUP menu and select ISOPOTENTIAL. Adjust the reading as required using the numeric keys

and press .



RESOLUTION

Enter pH SETUP menu and select RESOLUTION. Select the preferred resolution (0.001, 0.01 or 0.1) from

a set of pre-defined options using the arrow keys and press .

3.7 ENTERING pH BUFFER VALUES



The Model 3345 allows pH buffer values to be entered in two ways - either in pH SETUP or CALIBRATION.

Select the pH mode using the arrow keys and press . Move the cursor to highlight the SETUP menu option and press . Select the CAL BUFFERS... menu option using the arrow keys and press .

Selecting this menu allows access to 3 buffer settings. Buffer values can be entered in any order and do not need to be incremental or decremental.

Adjustment can be made by entering the required buffer value via the numeric keys.

If a mistake is made the  key can be used as a delete key, starting from lowest digit. If you wish to alter the entered value keep pressing this key until a blank box appears. Pressing the key again will default to the original value.

Once the correct value is entered pressing the  key will update the display to the new value corrected to 3 decimal places. If you wish to abort pressing the  key will return the cursor to CAL 1 BUFFER.

If a value which is higher or lower than the preset instrument default values is entered the unit will automatically default to the appropriate default values (above or below).

Values can be entered as exponential numbers and these will be shown as standard values.

It is possible to change polarity at any time but the -ve sign can only be applied after entering a number.

CALIBRATION MODE

Buffer values can be changed at the point of calibration, eliminating the need to exit the calibration routine. On entering the CAL mode the menu option CAL BUFFERS should be selected and appropriate values should be entered using the numeric keypad.

3.8 pH CALIBRATION - AUTOMATIC

Auto buffer recognition operates over the range of 0 to 100°C and will recognise 2.00, 4.00, 7.00, 9.22 and 10.00pH. If calibration values other than 2.00, 4.00, 7.00, 9.22 and 10.00 are set the instrument will consider this to be a manual buffer calibration.

NOTE: Rinse electrode(s) in deionised water between measurements.

Calibration is performed by selecting the pH mode and then moving the cursor to the CAL menu option and pressing . The instrument will then show:

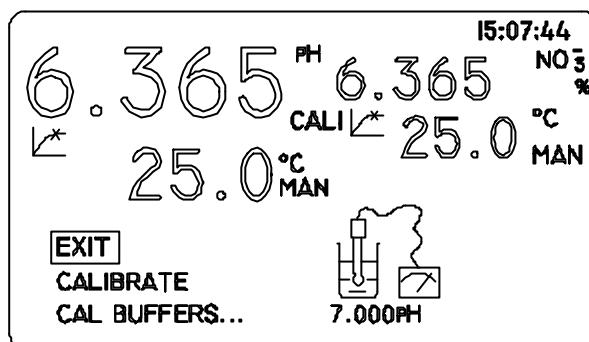



An icon will appear indicating the CAL 1 buffer value and the first part of the calibration. The buffer value(s) can be changed at this point by entering the CAL BUFFERS... menu and setting new values by using the numeric keys and pressing .

To calibrate the instrument select the CALIBRATE menu option using the arrow keys. The electrode(s) should be placed into the first buffer solution and the reading allowed to stabilise (the endpoint symbol will be displayed) prior to pressing the  key. The display will then update to the standard buffer value, corrected for temperature (actual temperature will be displayed).

The icon will then change to show the CAL 2 buffer value. If a one point calibration only is required select the EXIT option using the arrow keys and pressing . The instrument will return to the pH mode.

If a two point calibration is required the electrode(s) should be rinsed and then placed into the second buffer solution. Allow the reading to stabilise (the endpoint symbol will be displayed) prior to pressing the  key. The display will then update to the standard buffer value, corrected for temperature (actual temperature will be displayed).

The icon will then change to show the CAL 3 buffer value. If a two point calibration only is required select the EXIT option by using the arrow keys and press  . The instrument will then return to the pH mode.

If a three point calibration is required the electrode(s) should be rinsed and then placed into the third buffer solution. Allow the reading to stabilise (the endpoint symbol will be displayed) prior to pressing  . The display will then update to the standard buffer value, corrected for temperature (actual temperature will be displayed). The instrument will then return to the main pH display.

Once calibration is completed the instrument is now ready to perform sample measurement.

Rinse electrode(s) and place in sample. Allow the reading to stabilise (the endpoint symbol will be displayed).

Repeat for each sample

At the end of sample measurement re-check the calibration of the instrument using one standard solution.

3.9 pH CALIBRATION - MANUAL

Select the pH menu. Entering buffer values manually can be carried out in either the pH SETUP MENU or in CALIBRATION mode.

Calibration is performed by selecting the pH mode and then moving the cursor to the CAL menu option and pressing  .

An icon will appear indicating the CAL 1 buffer value and the first part of the calibration. The buffer value(s) can be changed at this point by entering the CAL BUFFERS... menu and setting new values by using the numeric keys and pressing  .

To calibrate the instrument select the CALIBRATE menu option using the arrow keys. The electrode(s) should be placed into the first buffer solution and the reading allowed to stabilise (the endpoint symbol will be displayed) prior to pressing the  key. The display will then update to the standard buffer value, corrected for temperature (actual temperature will be displayed).

The icon will then change to show the CAL 2 buffer value. If a one point calibration only is required select the EXIT option using the arrow keys and pressing  . The instrument will return to the pH mode.

If a two point calibration is required the electrode(s) should be rinsed and then placed into the second buffer solution. Allow the reading to stabilise (the endpoint symbol will be displayed) prior to pressing the  key. The display will then update to the standard buffer value, corrected for temperature (actual temperature will be displayed).

The icon will then change to show the CAL 3 buffer value. If a two point calibration only is required select the EXIT option by using the arrow keys and press  . The instrument will then return to the pH mode.

If a three point calibration is required the electrode(s) should be rinsed and then placed into the third buffer solution. Allow the reading to stabilise (the endpoint symbol will be displayed) prior to pressing  . The display will then update to the standard buffer value, corrected for temperature (actual temperature will be displayed). The instrument will then return to the main pH display.

Once calibration is completed the instrument is now ready to perform sample measurement.

Rinse electrode(s) and place in sample. Allow the reading to stabilise (the endpoint symbol will be displayed).

Repeat for each sample

At the end of sample measurement re-check the calibration of the instrument using one standard solution.

3.10 ERROR CODES

If a problem is detected during calibration the following error codes will be displayed;

CAL OUT OF RANGE

This indicates that the instrument has calculated an electrode offset at pH7 outside the -30 to +30mV limits. The error code will be displayed for 3 seconds and will then reset the calibration back to the ideal Nernst response (0mV @ pH 7, 59.16mV/pH @ 25°C).

SLOPE OUT OF RANGE

This indicates that the slope value is out of range. The error code will be displayed for 3 seconds and will then reset the calibration data back to the ideal Nernst response (0mV @ pH 7, 59.16mV/pH @ 25°C).

3.11 GOOD PRACTICE GUIDELINES

The following information contained within Section 3.1 is given as a general guide only. For more specific detail regarding the pH electrode(s) you may be dealing with, please refer to the Technical Data Sheet supplied with the electrode(s).

pH ELECTRODES

The types of electrodes are many and various. For the majority of tests carried out on aqueous solutions with a reasonable ionic strength, at ambient temperatures and with limited use in strongly acidic or alkaline solutions, the standard glass or epoxy bodied electrode is ideal. For other applications a more suitable pH/reference electrode pair may be required, details or advice available on request.

The following general guidelines indicate the care and maintenance required for the three main groups of electrodes, i.e. combination, reference and pH.

- 1) After Use Rinse thoroughly with distilled water
 Short Term Storage Immerse in pH4 buffer
 Long Term Storage Fit wetting cap with pH7 buffer (combination)
 Fit wetting cap with pH4 buffer (Reference/pH)

- 2) Electrodes should be stored: a) away from direct sunlight
 b) in a vertical position
 c) within their specified temperature range

- 3) Always ensure the electrode is used within its specified temperature range. Ageing of electrodes used above their specified temperature is rapid and irreversible.

- 4) Ensure the level of the fill solution is above the internal elements in the electrode and that this level remains above the sample level in use.

- 5) DO NOT touch the sensitive glass pH membrane or reference junction during use. Excess droplets of solution may be removed by gently blotting with filter paper or tissue. DO NOT rub the electrode as this may induce an electrostatic charge.

- 6) Ensure no air bubbles are trapped at the bottom of the electrode. Removal of the air bubbles is possible by holding the electrode vertically and gently tapping the electrode body. Larger bubbles may be removed by shaking the electrode in a downward direction.

7. During use ensure the electrode is rinsed between each measurement to eliminate contamination of solutions.

8. Ensure that the side port/inlet is uncovered, especially during a long run of tests.

3.12 mV MODE - SETTING UP PARAMETERS

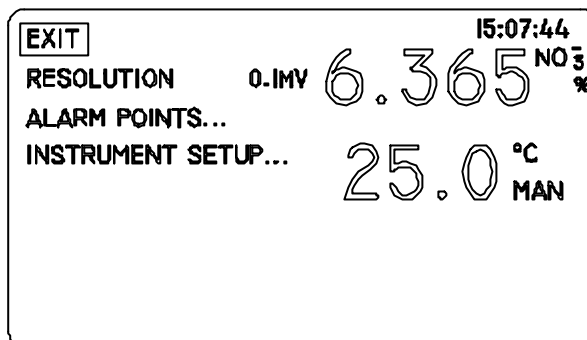

- EXIT** menu escape key
- RESOLUTION** allows the number of decimal places for the measured parameter on the display to be changed using the arrow keys
- ALARM POINTS....** allows the alarm points for the selected mode and channel to be viewed and changed
- INSTRUMENT SETUP...** used to select the next set up menu for instrument parameters

RESOLUTION

Enter mV SETUP menu and select RESOLUTION. Select the preferred resolution (0.1 or 1mV) from pre-defined options using the arrow keys and press .

Absolute Millivolts

When this mode is selected the unit will display the actual voltage developed by the electrode when it is immersed in a solution containing ions to which the electrode is sensitive. The electrode may be a combination type or a suitable sensing/reference pair, depending on the specific test being carried out.

pH, Redox and Ion Selective electrodes can all be used in this mode. Most of these determinations will require the preparation of calibration curves or other analytical methods to enable the mV reading to be converted to a concentration unit. For further information on these determinations refer to the electrode instructions, which will normally give details of calibration solutions, interferences and the limits of the methodology.



A very useful application of the Absolute mV range is for monitoring the performance of standard pH electrodes. Using accurate and fresh buffers at a constant temperature, the millivolt output of the electrode should be noted and compared to the theoretical ideal. As the electrode ages, becomes contaminated or dirty, these values will drift, indicating that corrective action should be taken. Recording these values as part of a routine Quality Control program can give a good indication of the condition of the electrode.

Relative Millivolts

This mode is suitable for determinations using Redox and Ion Selective Electrodes and has the additional benefit of being able to zero any offset voltage developed by the electrode in a blank solution, i.e; a solution that has none of the ions to be measured, but has all the other characteristics of the unknown samples. A blank solution would normally have its ionic strength and pH adjusted as required for the electrode in use. As the display is zeroed automatically when the Relative millivolt mode is selected, it is necessary to immerse the electrode in the blank solution with the Absolute mV mode selected. When the reading has stabilised the Relative mV mode should then be selected. The display will be set to zero, thereby removing any offset voltage.

Sample measurement is then carried out by using a variety of well tried analytical methods; from simple calibration curves through titrations, to single and multiple addition methods.



mV Measurement

Select the mV mode by using the arrow keys and pressing . The instrument can toggle between Absolute and Relative millivolts by using the  key with REL or ABS menu option highlighted. Relative mV is indicated by REL appearing on the display.

3.13 TEMPERATURE MEASUREMENT

The instrument will operate with one or two probes connected for automatic temperature compensation. If two probes are connected and one fails, the instrument will automatically revert to the remaining good sensor and both displays will show this value.

If both sensors fail the instrument will revert to manual temperature measurement.

Manual values can be entered via the SETUP and INSTRUMENT SETUP... menus and selecting MAN TEMPERATURE using the arrow keys and pressing . Adjustment is made using the numeric keypad and pressing .

3.14 ION SELECTIVE MEASUREMENTS

Methods of Analysis

Measurements with Ion Selective Electrodes are often carried out with simple and straightforward calibration techniques, over a linear range of concentration. Concentration can be determined Ion Selective Electrodes in two ways.

Direct potentiometry relates directly to the measured potential for the electrochemical cell to concentration or activity of a given ion in solution, or its logarithm (only pH). Usually a procedure is followed in which a calibration graph is prepared, with voltage plotted against activity or concentration. The plot is usually linear over a range from 1 to 5 pX units, except at higher concentrations where activity and concentration are not identical. Calibration methods are useful provided the measured solution does not contain interfering ions which form complexes or precipitates with the test ions, or the measured potential is not affected by other ions present in the test solution. The activity coefficients of the test and standard solutions must be roughly similar, which can be achieved by the addition of Ionic Strength Adjustment Buffers (ISAB or TISAB) to both sample and standard solutions. As the electrode responds to the activity of the uncomplexed analyte ion, an excess of an inert salt is added to ensure both standards and test solutions have a constant high ionic strength. This enables activity to be related directly to concentration. Alternatively, standard and sample addition techniques are used to avoid these sources of error.

Another application of Ion Selective Electrodes for the determination of concentration is a potentiometric titration, in which changes in potential of the indicator electrode are a function of the volume of the reagent solution added. The results by this method are usually more precise than those obtained by direct potentiometry.

The potential of an ion selective electrode is measured against the constant fixed potential of a reference electrode also in contact with the solution. The three most common types of reference electrodes are the calomel, mercurous sulphate and double junction.

The calomel is the most widely used of the three and contains a saturated potassium chloride filling solution. Potassium chloride is often used as an electrode fill solution because the mobilities of K^+ and Cl^- are similar, thus the junction potential at the interface is relatively small. The mercurous sulphate reference electrode is similar to a calomel electrode although not as useful due to its high liquid junction potential. It uses a potassium or sodium sulphate filling solution, so is used when potassium or chloride contamination of the sample is undesirable. The double junction has an inner chamber containing 3.8M $KCl/AgCl$, which is insulated from the sample solution by a second chamber containing a solution to which the ion selective electrode does not respond.

Double junction reference electrodes are used in sludge or organic/caustic solutions and where potassium or chloride in the calomel internal reference will interfere with the ion measurement and when interferents are present. Refer to ion selective electrode manufacturer's specification for recommended buffer solution.

Changes in temperature have an effect upon the electrode potential and sensitivity of both ion selective electrode and reference electrodes. The measuring range is often reduced with an increase in temperature, although this will vary with the individual electrode type. According to the Nernst equation the effect of temperature is the same for all ion selective electrodes. However, because of the temperature effects of the different materials used to make an electrode, each type of electrode has a different voltage change with temperature. There is a theoretical electrode potential which is independent of temperature, although this value is difficult to determine, and is a characteristic of each individual electrode. Therefore, the best approach is to ensure that both standard solutions and sample solutions are at the same temperature.

Ionic Strength Adjustment Buffers (ISAB) raise the total ionic strength of the sample and standard solutions to a level which makes initial variation insignificant. Addition of ISAB also improves electrode sensitivity and

linearity of the calibration curve. The ionic strength of a solution is the collective effect of the charge and concentration of all the ions present and is expressed as the activity coefficient. Total Ionic Strength Adjustment Buffers (TISAB) contain an ionic strength adjuster, as well as a pH buffer, thus eliminating H⁺ and OH⁻ interference, and undesired chemical reactions. Decomplexing agents are also added to complex or precipitate interfering ions which may be present in sample solution.

Direct Potentiometry (mV mode)

Absolute and Relative mV

This is the most straightforward method to obtain results. A series of serial dilutions of a standard solution is measured. The electrode potential of an unknown following calibration of the system by a series of serial dilutions. A small volume of ISAB is added to both standard and test solutions to eliminate effects of differences in activity.

The temperature must be kept constant between samples and standard. Within the linear range of the electrode two standards are sufficient or additional points if low concentration expected outside linear range.

Procedure:

refer to electrode manual for specific electrode preparation.

prepare at least two standards within the linear range of the electrode, with concentration differing by a factor of 10.

add constant volume of ISAB to sample and standard solutions.

ensure meter is reading millivolts.

place electrode in most dilute standard, record value when reading is stable.

rinse electrode and measure the next standard, following procedure as above.

repeat for each additional standard solution.

rinse electrode and place in sample.

repeat the above for each sample.

recheck calibration of the meter using one standard solution.

Fluoride	mV	slope
1ppm	-400	
10ppm	-459	-59
100ppm	-518	

Calcium	mV	slope
1ppm	332	
100ppm	361	+29
1000ppm	390	

3.15 ION SELECTIVE ELECTRODES - GOOD PRACTICE GUIDELINES

1. Always start with the lowest concentration first if plotting a calibration curve.
2. Wipe the membrane with tissue between measurements.
3. Stir solutions wherever possible and ensure that all measurements are performed at a constant temperature.
4. Do not leave solid state electrodes in solution when not in use. Store safely to ensure the electrode is not damaged.

For further details refer to the specific specification sheet supplied with the individual electrode.

3.16 CONCENTRATION MODE

Connect the electrode(s) and ATC probe(s) if used to the appropriate rear panel sockets.

Select the CONC mode using the arrow keys and press .

Select SETUP mode using the arrow keys and press .

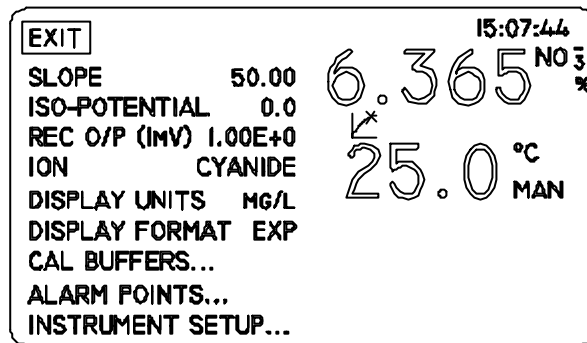

EXIT	menu escape key
SLOPE	allows the sensor slope for the selected ion and channel to be changed
ISO-POTENTIAL	allows the sensor iso-potential for the selected ion and channel to be changed
REC O/P (1mV)	allows recorder output sensitivity to be entered. The value entered will give a 1mV change in recorder output
ION	allows the ion selective electrode being used or channel using the arrow keys This allows the instrument to check the sensor slope during calibration, using the valency of the ion. Changes in display units will also correct all displayed concentrations using the relative atomic/molecular mass for ion. If the ion selective electrode used is not included on the instrument then ION+, ION++, ION- or ION-- should be selected depending on the valency of the ion
DISPLAY UNITS	allows selection of measurement unit appropriate to sample under test - ppm, M, mg/l, Act, none, %
DISPLAY FORMAT	allows the format for concentration readings to be selected between integer and exponential format. If set to integer, then readings will be displayed with an exponent part if the reading is less than 0.001 or greater than 9999
CAL BUFFERS...	allows the calibration buffers for the selected mode and sensor input to be viewed and changed
ALARM POINTS...	used to view and change alarm points for the selected mode and channel
INSTRUMENT SETUP...	used to select the next set up menu for instrument parameters

SLOPE (1 point cal)

Enter SETUP menu and select SLOPE. Adjust the reading as required using the numeric keys and press



. The reading will default to 2 decimal places.

ISOPOTENTIAL POINT

Enter SETUP menu and select ISOPOTENTIAL. Adjust the reading as required using the numeric keys

and press .

REC O/P (1mV)

Enter SETUP menu and select REC O/P (1mV). Adjust the reading as required using the numeric keys

and press .

ION

Enter SETUP menu and select ION. Select the required ion selective electrode and press .

DISPLAY UNITS

Enter SETUP menu and select DISPLAY UNITS. Select the required measurement unit (ppm, M, mg/l,

Act, none, %) and press .

DISPLAY FORMAT

Enter SETUP menu and select DISPLAY FORMAT.

Select the integer or exponential format and press .

3.17 CALIBRATION

A one point calibration should be performed after manually entering the sensor slope. The slope entered is checked against the ideal Nernstian slope for the ion, and must be 75-125% of the ideal. The slope displayed is corrected to the current temperature. For 2 - 5 point calibrations the instrument will automatically set the slope value.

Procedure:

Refer to electrode manual for specific electrode preparation.



Prepare at least two standards (up to a maximum of 5) within the linear range of the electrode, with concentration differing by a factor of 10.

Add a constant volume of ISAB to the sample and standard solutions.

Having set the necessary instrument parameters in the SETUP and INSTRUMENT SETUP modes the following calibration procedure should be carried out:

3.18 ENTERING CAL BUFFER VALUES



The Model 3345 will allow these values to be entered in two ways - either in SETUP or CALIBRATION.

Select the CONC mode using the arrow keys and press . Move the cursor to highlight the SETUP menu option and press . Select the CAL BUFFERS... menu option using the arrow keys and pressing .

Selecting this menu allows access to five settings. Values can be entered in any order and do not need to be incremental or decremental.

Adjustments can be made by entering the required value via the numeric keypad.

If a mistake is made the  key can be used as a delete key, starting from lowest digit. If you wish to alter the entered value keep pressing this key until a blank box appears. Pressing the key again will default to the original value.

Once the corrected value is entered pressing the  key will update the display to the new value corrected to 3 decimal places. If you wish to abort pressing the  will return the cursor to CAL 1.

If a value which is higher or lower than the preset instrument default values is entered the unit will automatically default to the appropriate default values (above or below).

Values can be entered as exponential numbers and these will be shown as standard values.

It is possible to change polarity at any time but the -ve sign can only be applied after entering a number.

Buffer values can be changed at the point of calibration, eliminating the need to exit the calibration routine. The instrument is now ready to perform a calibration.

Calibration is performed by selecting the CONC mode and then moving the cursor to the CAL menu option and pressing  . The instrument will then show:

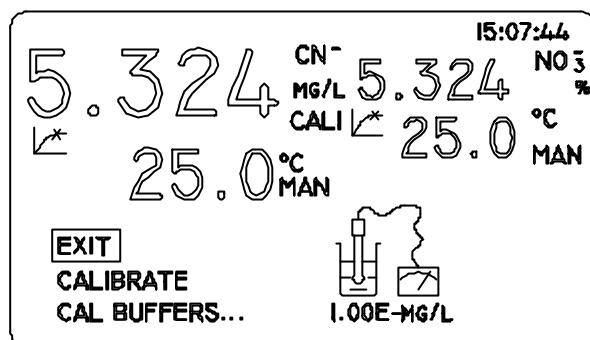

An icon will appear the CAL 1 buffer value and the first part of the calibration. The display will also indicate CAL 1 to the right hand side of the main reading. The buffer values can be changed at this point by entering the CAL BUFFERS... menu and setting new values by using the numeric keys and pressing  .

To calibrate the instrument select the CALIBRATE menu option using the arrow keys. The electrode(s) should be placed in the most dilute standard and the reading allowed to stabilise. (the endpoint symbol will be displayed) prior to pressing the  key. The display will then update to the standard buffer value, corrected for temperature (actual temperature will be displayed).

The icon will then change to show the CAL 2 buffer value . If a one point calibration only is required select the EXI T option using the arrow keys and pressing  . The instrument will return to the CONC mode.

If a 2, 3, 4 or 5 point calibration is required the electrode(s) should be placed in the appropriate standards in turn, rinsing between each measurement. Once the required number of calibration points are completed select the EXIT option. The instrument will return to the CONC mode.

Once calibration is completed the instrument is now ready to perform sample measurement. Rinse electrode(s) and place in the sample. Allow the reading to stabilise (the endpoint symbol will be displayed). Repeat for each sample. At the end of sample measurement re-check the calibration of the instrument using one standard solution.

NOTE: Accuracy will be dependent upon the number of calibration points performed.

3.19 INCREMENTAL METHODS

Incremental methods are particularly useful for single sample analyses, as usually one standard solution and two potential measurements are necessary. The effects of variable temperature and ionic strength are eliminated by the large dilution effects. However, the volumes of the solutions must be accurately measured.

Known Standard or Sample Addition

The calculation for this technique has been programmed into the Model 3345.

In cases where the composition of the test solution is unknown or complex, the standard addition method is employed. In this technique, the electrode is immersed in a known volume of the unknown solution and the potential is recorded. A small measured volume of a standard solution is added and the potential measured. The measured potential difference is used to solve the incremental technique equation to give concentration of the unknown solution.

Alternatively, the electrode is immersed in a known volume of a standard solution and small measured volumes of the unknown are added, following the same procedure. Appropriate when low sample volume or high concentration. Results are more accurate if the effects of severe additions are averaged.

Known Standard or Sample Subtraction

The calculation for this technique has been programmed into the Model 3345.

In this method a small volume of reagent which complexes or precipitates the ion under investigation is added to a known volume of the sample. Thus, there is a decrease in ion concentration and corresponding decrease in measured potential. The measured difference potential is used to solve the incremental technique equation to give concentration of the unknown solution. This method is preferred when standard solutions of the ion are unstable, of unknown concentration or toxic. This method is also used when the sample ion concentration is high and known addition procedures produce small changes in potential.

Alternatively, a small volume of unknown sample is added to a volume of standard solution which the test ion will react with to form a precipitate or complex. The electrode used is sensitive to the ion in the standard solution rather than the unknown solution ion. Therefore, measurements can be made for an ion for which no electrode exists, if a system of reaction can be found.

Multiple Sample Addition

This mode of operation enables a large number of samples to be analysed using only one standard solution. In this technique, the electrode is immersed in a known volume of a standard solution and the potential is recorded. A small measured volume of an unknown solution is added and the potential measured. The measured potential difference is used to solve the incremental technique equation to give concentration of the unknown solution. A further addition of a measured volume of an unknown solution is added, either a new solution or second sample of the original solution. The concentration of the second unknown solution is calculated, allowing for the change in volume using the change in potential to calculate the concentration of the subsequent sample solution.

Titration

The principle of ion selective electrode titrations is based upon the reaction of two species in solution, the endpoint being characterised by the total disappearance of one of the species or creation of a new reaction product. Using an ion selective electrode as an indicator to monitor the reaction, an accuracy of 0.1 - 0.5% can be achieved. Titrimetric methods can also be used not only to directly measure the presence of an ionic species, but indirectly to measure an ion by the formation of complex with a measurable ionic species.

INCREMENTAL METHODS

3.20 KNOWN ADDITION/SUBTRACTION



This menu option will begin a known addition measurement. The sample concentration is calculated using:





$$C_u = \frac{C_s \cdot V_s / (V_u + V_s)}{10^{E/S} - V_u / (V_u + V_s)}$$





Where:



C _u	=	Sample concentration
C _s	=	Standard concentration
V _s	=	Volume of standard
V _u	=	Volume of sample
E	=	Change in electrode potential
S	=	Slope of electrode

To perform a measurement the following procedure should be carried out:

Select KNOWN ADDITION/SUBTRACTION mode using the arrow keys and pressing . Enter the SETUP... menu using the  arrow key and pressing . This menu option gives access to the parameters relating specifically to a known addition or subtraction measurement.

Select SAMPLE VOLUME using the  arrow key. Press . The value will now be highlighted. Adjust the reading as required using the numeric keys. If a mistake is made the  key can be used as a delete key, starting from the lowest digit. If you wish to alter the entered value keep pressing this key until a blank box appears. Pressing the key again will default to the original value. Once the correct value is entered pressing the  key will update the display to the new value.

Select STANDARD VOLUME using the  arrow key. Press . The value will now be highlighted. Adjust the reading as required using the numeric keys. If a mistake is made the  key can be used as a delete key, starting from the lowest digit. If you wish to alter the entered value keep pressing this key until a blank box appears. Pressing the key again will default to the original value. Once the correct value is entered pressing the  key will update the display to the new value.

Select STANDARD CONC using the  arrow key. Press . The value will now be highlighted. Adjust the reading as required using the numeric keys. If a mistake is made the  key can be used as a delete key,

starting from the lowest digit. If you wish to alter the entered value keep pressing this key until a blank box appears. Pressing the key again will default to the original value. Once the correct value is entered pressing the  key will update the display to the new value.

Once the values have been entered select CONC SETUP... if required or EXIT using the arrow keys and press .



The display will now give the message IMMERSE ELECTRODE IN SAMPLE SOLUTION... and the first icon will flash to indicate that the electrode(s) should be placed in the solution.

Select CONTINUE... using the arrow keys and press .

The display will now give a reading and the second icon will flash to indicate that a measurement is in progress. Pressing CONTINUE... again and the  key will cause the third icon to flash, requesting that the known volume of standard should be added to the sample.

Allow the reading to stabilise (the endpoint symbol will be displayed) and press . The display will show the value of the sample.

The display will update to show NEW MEASUREMENT... and STORE. The icon will flash to indicate that the next measurement may be performed.

Select NEW MEASUREMENT... using the  arrow key and press . The measurement sequence will commence as before.

Selecting STORE will allow the displayed reading to be stored.

On completion of measurements selecting EXIT and pressing  will return the instrument to the CONC menu.

3.21 MULTIPLE SAMPLE ADDITION/SUBTRACTION

This menu option will begin a sample addition measurement. The sample concentration is initially calculated using:

$$C_u = \frac{C_s \cdot (V_u + V_s) \cdot (10^{ES} - V_s / (V_s + V_u))}{V_u}$$

Where:

C _u	=	Sample concentration
C _s	=	Standard concentration
V _s	=	Volume of standard
V _u	=	Volume of sample
E	=	Change in electrode potential
S	=	Slope of electrode



If a subsequent sample is added to perform a multiple sample addition measurement, then the sample concentration is recalculated using the above expression but with the cumulative standard volume and the nth sample volume. The standard concentration is found using:



$$C_m = \frac{C_s \cdot V_s + C_u \cdot V_u}{V_s + V_u}$$





Where:

C _m	=	Concentration of mixture
C _s	=	Concentration of standard
V _s	=	Volume of standard
C _u	=	Concentration of previous sample
V _u	=	Volume of previous sample





To perform a measurement the following procedure should be carried out::





Select SAMPLE± mode using the arrow keys and pressing . Enter the SETUP... menu using the  arrow key and pressing . This menu option gives access to the parameters relating specifically to a sample addition or subtraction measurement.

Select NUMBER OF SAMPLES using the  arrow key. Press . Enter the number of samples using the numeric keys and press . It is recommended that for optimum accuracy of readings only four samples be measured at one time.

Select SAMPLE #1 VOLUME using the  arrow key. Press . Adjust the reading as required using the numeric keys. If a mistake is made the  key can be used as a delete key, starting from the lowest digit. If you wish to alter the entered value keep pressing this key until a blank box appears. Pressing the key again will default to the original value. Once the correct value is entered pressing the  key will update the display to the new value.

Select SAMPLE # 2 - 4 as required and adjust the values.

Select STANDARD VOLUME using the  arrow key. Press . Adjust the reading as required using the numeric keys. If a mistake is made the  key can be used as a delete key, starting from the lowest digit. If you wish to alter the entered value keep pressing this key until a blank box appears. Pressing the key again will default to the original value. Once the correct value is entered pressing the  key will update the display to the new value.

Select STANDARD CONC using the  arrow key. Press . Adjust the reading as required using the numeric keys. If a mistake is made the  key can be used as a delete key, starting from the lowest digit. If you wish to alter the entered value keep pressing this key until a blank box appears. Pressing the key again will default to the original value. Once the correct value is entered pressing the  key will update the display to the new value.

Once the values have been entered select CONC SETUP... if required or EXIT using the arrow keys and press .



The display will now give the message IMMERSE ELECTRODE IN STANDARD... and the first icon will flash to indicate that the electrode(s) should be placed in the solution.



Select CONTINUE... using the arrow keys and press .

The display will now give a reading and the second icon will flash to indicate that a measurement is in progress. Pressing CONTINUE... again and the  key will cause the third icon to flash, requesting that the addition of sample 1 is required.

Allow the reading to stabilise (the endpoint symbol will be displayed) and press . The display will show the value of the sample.

The display will update to show NEXT SAMPLE..., NEW MEASUREMENT... and STORE. The icon will flash to indicate that the next measurement may be performed.





Select NEW SAMPLE... using the  arrow key and press . The measurement sequence will commence as before.

Select NEW MEASUREMENT... using the  arrow key and press . Select SETUP... as before and enter new sample and standard values. Once set the measurement sequence will commence as before.

Selecting STORE will allow the displayed reading to be stored.

On completion of measurements selecting EXIT and pressing  will return the instrument to the CONC menu.

3.22 OPERATING THE INSTRUMENT WITH OPTIONAL STIRRER



The Model 3345 may be used with the optional bench and overhead stirrers. The stirrer should be connected to the instrument via the rear panel socket. Stirrer speed can be set by entering the SETUP and INSTRUMENT SETUP modes using the arrow keys and pressing . Select STIRRER OUTPUT (%) using the  arrow key and press  or .

Adjust the stirrer speed using the numeric keypad. Once set, select EXIT and press  to return to the main menu.

3.23 DATALOGGING

STORING RESULTS

The STORE menu is used to store the displayed readings in any measurement mode. Select the STORE menu by using the arrow keys and pressing . When the STORE key is pressed the display will show the main and auxiliary readings, the previous menu options will be replaced by a new set containing the menu option ABORT NN (NN is the first available free location of the displayed reading).

To store the displayed reading at the current index number the  key should be pressed. If no key is pressed within 5 seconds the reading will be automatically stored in this location. The instrument will then return to the previously selected mode. If the reading is not to be stored, moving to the ABORT option using the arrow keys and pressing  will return the instrument to the previously selected mode without storing the reading. To store a reading in a specific location use the arrow keys to select the required location and press . If no other key is pressed within 5 seconds the reading will be automatically stored in this location. The instrument will then return to the previously selected mode.



NOTE: Automatic storage after 5 seconds is only instigated after the last key press. If a key is pressed and held down the timer is disabled until the key is released. At this stage the 5 second timer is re-initialised.

The non-volatile storage area has the facility to store 100 readings. If, however, an attempt is made to store a reading with all locations full, the highlighted message MEMORY FULL will be displayed, returning the highlighting to the ABORT option. If it is necessary to store the reading the location will have to be selected within the index option using the arrow keys.



NOTE: Storing a reading when the memory is full will overwrite any previous data stored in the selected location.

RECALLING STORED READINGS

To recall a stored reading select the RECALL menu option by using the arrow keys and then pressing . The display will update to the stored reading and the stored index number will be shown at the bottom of the display. If no stored reading is present the display will give the message NO RECORD STORED.

To select a specific stored reading, select the RECORD # option using the arrow keys and press . To select the required location use the arrow keys. The display will update to the selected reading. To exit the RECALL mode select the EXIT option and press . The instrument will return to the previous display.

CLEARING STORED READINGS

To clear an individual stored reading select the RECALL mode using the arrow keys and press . Select RECORD # by using the arrow keys and pressing ENT. Select the specific location to be deleted by using the arrow keys. Move to the DELETE menu option by using the arrow keys and press . The display will clear and update to show the message NO RECORD STORED, returning the highlighting to the location number.

Selecting the EXIT option and pressing  will return the instrument to the previous display.

To clear all stored readings select the CLEAR-ALL menu option using the arrow keys and press . The display will momentarily display the message DELETING... The display will then update to show the message ALL RECORDS DELETED.





Selecting the EXIT option and pressing  will return the instrument to the previous display.

DOWNLOADING STORED READINGS

To download or print stored readings press the  key from within the RECALL mode.

REAL TIME CLOCK SET UP

Real time clock set-up is performed by entering into the INSTRUMENT SETUP mode, selecting CLOCK SETUP using the arrow keys and pressing  .

Select the real time clock parameter to be changed using the arrow keys. Once highlighted adjustment of the parameter proceeds by pressing  . The first part of the parameter is highlighted and can be adjusted to the required value using the arrow keys. If further adjustment is required move the highlighted cursor to the next adjustable position using the  arrow key and adjust as required. Continue moving across the parameter until full adjustment has been made. to confirm new time or date press  or press the  key until the selected parameter is re-highlighted.

SECTION 4

MAINTENANCE

4.1 GENERAL

The Model 3345 is designed to give optimum performance with minimum maintenance. It is only necessary to keep the external surfaces clean and free from dust. To give added protection when the unit is not in use the unit should be disconnected from the mains supply and covered with the optional dust cover (544 008). For longer term storage or re-shipment it is recommended that the unit be returned to the original packing case.

4.2 CLEANING/RE-CONDITIONING OF GLASS ELECTRODES

For general purpose use combination electrodes can be cleaned with a mild detergent solution or a commercial glass cleaning solution (provided these are not strongly acidic). The electrode surface should be wiped with a clean cloth soaked in the cleaning agent, and/or allow the membrane to stand in the solution until clean. Rinse and repeat as necessary.

TABLE FOR CLEANING OF GLASS ELECTRODES

NOTE: Epoxy bodied electrodes should not be cleaned with aggressive solvents.

DEPOSIT	CLEANING AGENT
General deposits	Mild detergent solution
Inorganic coatings	Commercial glass cleaning solution (not strongly acidic)
Metal compounds	Acid solution, not stronger than 1M
Oil/Grease	Complexing agent (EDTA) or suitable solvent
Resins/Lignins	Acetone, alcohol or detergent (not strongly alkaline)
Proteins (blood, etc)	Enzyme solutions e.g. pepsin in 0.1M HCl
Stubborn deposits	Weak hydrogen peroxide solution, sodium hypochlorite solution or domestic bleach

Electrodes which have been allowed to dry out (often indicated by a hard, dry deposit of KCl crystals on the electrode body) should be rehabilitated by soaking overnight in warm distilled water.

4.3 ION SELECTIVE ELECTRODES

Refer to the Instruction Sheet supplied with the electrode.

SECTION 5

OPTIONAL ACCESSORIES

A wide range of optional accessories and electrodes are available for use with the Model 3345. Please consult your local Distributor or manufacturer for a full list.

SECTION 6

INTERFACING

Analog Outputs

The Model 3345 has 3 analog outputs - one is proportional to the current primary displayed reading - the other two are buffered electrode potential outputs.

Analog Output Proportional to Displayed Reading

The voltage is proportional to the displayed primary reading. In mV mode there is a direct relationship i.e. 1mV on the display = 1mV from the analog output. In pH mode 1mV = 0.01pH i.e. 7.000pH = 700mV, 2.345pH = 234mV. In concentration mode the user can set the sensitivity of the analog output using the REC mV menu option. The number entered on the menu option will cause a change of 1mV on the recorder output. So if REC mV is set to $1E^{-3}$, and the displayed concentration is 1.00 ($1.00E^0$), then the analog output will be $1.00E^0 / 1E^{-3} = 1000mV$.

Buffered Electrode Potential Analog Outputs

Each sensor input has a buffered analog output, which is available on the 25 way D socket.

25 way D Socket	pin 14	sensor 1 buffered output
	pin 22	sensor 1 buffered output ground
	pin 11	sensor 2 buffered output
	pin 18	sensor 2 buffered output

Karl Fischer

A polarised Karl Fischer output is provided. Karl Fischer titrations are enabled by the provision of a 10 μ A polarising current output.

RS232

The Model 3345 emulates data communicating equipment, which allows direct connection to the signals of data terminal equipment, such as personal computers and serial printers.

The Bi-directional RS232 interface is available on the rear panel 25 way D type connector.

The connections are as follows:

TXD 2	- INPUT TO 3345
RXD 3	- OUTPUT FROM 3345
RTS 4	- LINKED TO CTS
CTS 5	- LINKED TO RTS
DSR 6	- OUTPUT FROM 3345
DCD 8	- OUTPUT FROM 3345
DTR 20	- INPUT TO 3345 (must be active)
GND 7	

Suggested interconnections are detailed below:

3345		IBM PC XT (25 way "D")	
TXD	2	2	TXD (From PC)
RXD	3	3	RXD (To PC)
RTS	4	4	RTS (From PC)
CTS	5	5	CTS (To PC)
DSR	6	6	DSR (To PC)
DCD	8	8	DCD (To PC)
DTR	20	20	DTR (From PC)
GND	7	7	GND

3345		IBM PC XT (9 way "D")	
TXD	2	3	TXD (From PC)
RXD	3	2	RXD (To PC)
RTS	4	7	RTS (From PC)
CTS	5	8	CTS (To PC)
DSR	6	6	DSR (To PC)
DCD	8	1	DCD (To PC)
DTR	20	4	DTR (From PC)
GND	7	5	GND

The RS232 communications parameters on the computer or printer need to be set to match those of the Model 3345, as detailed below:

1200 Baud
7 Data Bits
Odd Parity
1 Stop Bit

The Model 3345 supports both hardware (DTR/DSR) flow control and software XON/XOFF flow control.

Pressing the PRINT key outputs from the RS232 interface.

Sending an ASCII "D" to the 3345 causes a printout of the current displayed reading plus sample number.

Sending an ASCII "C" causes a printout of the last calibration parameters (same as printout after performing a calibration).

Sending an ASCII "P" causes downloading of stored readings.

ALARM CONNECTIONS

Each sensor channel has independent alarms. When a reading goes outside the alarm limits, the 3345 activates an open collector transistor alarm output to indicate that a low or high alarm limit has been exceeded. Each transistor can sink up to 0.5A. The maximum no load voltage for each transistor is 50V dc.

The alarm transistor output connections are available on the 25 way D socket:

pin 12 sensor 1 open collector transistor low alarm output
pin 13 sensor 1 open collector transistor high alarm output
pin 10 sensor 2 open collector transistor low alarm output
pin 9 sensor 2 open collector transistor high alarm output
pin 17 ground connection for alarms

Both outputs will sink current to the common line (pin 7) i.e. the emitters of both alarm transistors are connected to pin 7.

NOTE: The open circuit voltage on pin 12 or pin 13 must not exceed 50V d.c. with respect to pin 7.

GLOSSARY OF TERMS

ABSOLUTE MILLIVOLTS (mV)

Most pH/Ion meters have a mV mode which allows the potential developed by the electrode to be directly displayed. This mode can be useful when assessing electrode performance and is normally employed when working with ion selective electrodes.

ACID

A solution which dissolves in water with the formation of hydrogen ions and reacts with a base to form a salt.

ACTIVITY

Effective concentration of free ions and ion pairs in a solution. In dilute solutions ($<10^{-4}\text{M}$) ionic concentration and activity are practically identical. The ionic activity rather than concentration determines the extent and rate of a chemical reaction.

ACTIVITY COEFFICIENT

Ions of similar size and charge have similar activity coefficients. For solutions of low ionic strength ($<10^{-4}\text{M}$) the activity coefficient is nearly 1 and lower for solutions of a higher ionic strength. The relationship between activity and concentration is described by the equation $a_i = C_i f_i$ where:

$$\begin{aligned} a_i &= \text{activity of ion } i \\ C_i &= \text{concentration of ion } i \\ f_i &= \text{activity coefficient} \end{aligned}$$

ALKALI

See Base

ANION

A negatively charged ion (Cl^- , NO_3^- , CO_3^{2-} , etc).

ASYMMETRY POTENTIAL

The potential developed across a glass pH membrane when both sides of the membrane are in contact with an identical solution. This term is also used to define an electrode potential developed in a pH7 buffer.

AUTOMATIC TEMPERATURE COMPENSATION (ATC)

A temperature sensor either incorporated into the pH electrode or in a separate probe which will correct the electrode response for changes in temperature (the T term in the Nernst Equation). ATC does not correct for changes that occur in the pH of samples with temperature. Meters that calibrate by automatically recognising buffers (ABR) will have the buffer temperature characteristics programmed into their software and calibrations will be automatically compensated. Meters that rely on manual calibration do not automatically compensate for temperature and reference needs to be made to the tables supplied with the buffers which relate to buffer value and temperature.

BUFFER

A solution which maintains a pH value (hydrogen ion concentration) when acids or alkalis are added.

BUFFER CAPACITY

Quantifies the ability of a solution to resist pH change when subject to the addition of strong acid or base.

BASE

A substance which dissolves in water with the formation of hydroxyl ions and reacts with acids to form salts. Has a $\text{pH} > 7$.

CALIBRATION

Electrode characteristics change with time and usage and solutions with known values are used to establish the standardisation point and electrode slope values.

CALOMEL REFERENCE

A reference electrode having an internal reference element of mercury/mercurous chloride. The filling solution is usually saturated potassium chloride with mercurous chloride. Widely used for pH measurement but not recommended for use at temperatures $>50^{\circ}\text{C}$.

CATION

A positively charged ion (Na^+ , Ca^{++} , NH_4^+ , H^+ , etc).

COMBINATION ELECTRODE

An electrode which combines both sensing and reference elements in one housing.

CONCENTRATION (units: M, ppm, g/l⁻¹)

The mass or total concentration of an ion in a solution includes both free ions bound to complexing species. The ISE's measured potential of a solution gives the activity of a given ion in solution, a decomplexing agent is required to liberate bound ions to measure total concentration.

DEBYE-HUCKEL ACTIVITY EQUATION

Equation which approximates the mean activity coefficient of each ion to the ionic strength of a solution.

DISSOCIATION CONSTANT (K_a ; units: mol/m³)

Indicates the extent to which a molecular species dissociates in solution, thus the smaller the value of K , the less the species has dissociated. Expressed as $K = \frac{[\text{A}^+] + [\text{B}^-]}{[\text{AB}]}$.

DIVALENT ION

A doubly charged ion. S^- is a divalent anion. Ca^{++} , Mg^{++} are divalent cations.

DOUBLE JUNCTION REFERENCE ELECTRODE

Used in place of a single junction reference electrode when the fill solution contains an ion which interferes or reacts with the ion being analysed. Two separate filling solutions are used, an outer non-interfering solution contacts the sample and an inner fill solution completes the electrical circuit of the reference cell.

DRIFT

Slow changes seen in electrode potential. Can often be minimised by careful attention to factors such as temperature constancy.

ELECTRODE POTENTIAL

The potential difference developed between an electrode and a solution when the electrode is immersed in that solution.

ELECTROLYTE

A compound that in solution dissociates into ions. Strong electrolytes are good conductors of electricity.

FILLING SOLUTION

A solution used in electrodes to make contact between an internal element and a membrane or sample. The filling solution of the internal reference element contains a fixed level of chloride. The concentration of this ion determines the zero potential of the electrode.

The filling solution is saturated with silver chloride to prevent erosion of the internal reference element.

Reference filling solution is a concentrated salt solution contacting the sample solution and the internal reference element.

GRAN PLOT

A mathematical transformation of the titration curve in order to improve a method's precision or limit of detection.

HYSTERESIS

Electrodes sometimes display a memory effect which is exhibited when moving between solutions of significantly different pH. Large changes in other ambient influences can also induce this effect, i.e. temperature or light levels.

INCREMENTAL METHODS

A variety of spiking techniques whereby known volumes of standard or sample solutions are added. They can be separated into known addition/subtraction and sample addition/subtraction.

INPUT IMPEDANCE

pH meters used in conjunction with glass pH electrodes must have a high input impedance to match the impedance of the glass membrane. This is typically 10^{13} ohms.

The signal developed by a pH electrode has very little power and the device, therefore, has a very limited capability to drive current into a measuring circuit.

With modern electronic devices the necessary input impedance is not difficult to achieve but can be degraded by a damp or dirty operating environment.

INTERFERENCE

Ion Selective Electrodes are highly selective but seldom respond specifically to a given ion. Different ions will respond to an electrode to variable amounts and this is expressed as its selectivity coefficient. A value of 10^{-3} means that a concentration of interferent ion 1000 times greater than the measured ion is required before an equal electrode response is seen.

INTERNAL REFERENCE ELEMENT

A reference electrode situated within the glass pH sensing electrode.

IONIC STRENGTH (I; units: mol/m³, mol/g)

The total effect of all of the ions present in a solution is expressed as the ionic strength and is given by:

$$\text{ionic strength} = 1/2 \sum C_i Z_i^2, \text{ where}$$

C = concentration of ion i

Z = the charge of ion i

n = the number of species present in the solution

The ionic strength determines the activity coefficient of each ion in solution.

ION SELECTIVE ELECTRODE

Electroanalytical sensors which respond selectively to specific ions, the signal depends upon the activities of the ions in solution. A potential develops across the membrane, an electrically conducting material which separates the solution from an internal solution or contact. These electrodes are classed as glass, liquid or solid-state.

ISAB (IONIC STRENGTH ADJUSTMENT BUFFER)

A solution of high ionic strength added to sample solutions before measurement to minimise differences in ionic strength between standard and test solutions, thus eliminating the effect of ion activity coefficient and permitting direct measurement of concentration. A non-interfering salt, pH buffer and decomplexing agent are used, although the formulation can vary.

ISOPOTENTIAL POINT

A point at which the potential developed by an electrode is not influenced by temperature. For a normal glass pH electrode this potential will be close to 7pH. Temperature effects are greater the further the level of the sample is from the isopotential point (see ATC and Temperature Effects).

KARL FISCHER TITRATION

A method for determining the water content of samples. A polarising current is applied to a pair of platinum electrodes immersed in a solution containing iodine, pyridine, methanol and sulphur dioxide. A polarising current, typically 10 microamps, is applied to the electrodes and the resulting potential is monitored.

LIQUID JUNCTION

The point of contact between the sample and the reference electrode filling solution.

LEAK RATE

The reference electrode fill solution will inevitably leak into the sample solution. An irregular leak rate may cause the liquid junction potential to vary causing unstable or drifting readings. Samples of small volume that need to be retained can also suffer an unacceptable level of contamination.

MEMBRANE

In a pH electrode the membrane is a thin pH sensitive glass. A potential difference is developed across the membrane due to the formation of double layers with ion-exchange properties.

MILLIVOLT

Based on the SI unit of potential difference, electrical potential or e.m.f. such that the potential difference across a conductor is 1 millivolt when a current of 1 milliamp flows through a resistance of 1 ohm.

MOLALITY

The concentration of a solution expressed as a number of moles of dissolved substance per kilogram of solvent.

MOLARITY

The concentration of a solution expressed as the number of moles of dissolved substance per dm³ of solution.

MONOVALENT ION

An ion with a single positive or negative charge (Na⁺, H⁺, Cl⁻, etc).

NERNST EQUATION

A mathematical relationship which describes the theoretical behaviour of pH electrodes

$$E = E_x + \frac{2.3 RT}{nF} \log a_i$$

E is the potential, in millivolts, developed between the sensing and reference electrodes.

E_x varies with the choice of reference electrodes and is a constant.

$\frac{2.3 RT}{nF}$ is the Nernst Factor. R is the gas constant, i.e. 8.31441 J.K⁻¹ mol⁻¹.

T is the thermodynamic temperature (in K)

n is an integer with sign and magnitude corresponding to the charge on the ion.

F is the Faraday Constant and is equal to 9.648456 x 10⁴ C.mol⁻¹.

A_i is the activity of the ion to which the electrode is responding.

At T=25°C, E is equal to 59.16mV when n=1.

NOISE

Random and rapid changes in displayed electrode potential. This is often due to the pick-up of strong static charges or electromagnetic interference from adjacent equipment.

OPEN CIRCUIT

The symptoms of an open circuit are either large jumps in displayed reading or a continual drift leading to an out of range reading.

The measurement circuitry relies on good contact of both the inner element and screen of the sensor to the instrument input.

pH ELECTRODE

An electrode which is specifically sensitive to hydrogen ion activity. Electrodes will normally perform satisfactorily over the entire 0 - 14pH range, but under certain circumstances anomalies can exist in strongly acidic solutions (acid error) and, more commonly, in alkali solutions by response to sodium or other cations (sodium error) in basic solutions.

Special electrode configurations are available to suit most analytical situations.

pH UNIT

A logarithmic index for the hydrogen ion concentration in an aqueous solution. Given by:

$$\text{pH} = \log_{10} \frac{1}{\text{H}^+}$$

i.e. a solution of pH7 is 10^{-7}M in hydrogen ion activity and a pH8 solution is 10^{-8}M .

POTENTIAL

When two phases containing electrically charged particles come into contact, an electrical potential difference develops. The potential of an ISE is measured against a suitable constant potential (reference electrode).

POTENTIOMETRY

A method of directly measuring wither concentration or activity of a sample solution by comparison with results from two or more known standards. The temperature, ionic strength, pH and composition of the standard and sample solutions must be kept constant.

PRIMARY STANDARDS

A range of aqueous buffer solutions defined by the National Bureau of Standards (N.B.S) in the U.S and by British Standards Institute (BS1647) which provide stable liquid junction potential and uniform electrode sensitivity.

REDOX POTENTIAL

The potential developed by a metallic electrode when placed in a solution containing a species in two different oxidation states.

REDOX ELECTRODE

These units have a metallic sensing element, usually platinum but sometimes gold, which monitors oxidation reduction reactions.

REFERENCE ELECTRODE

The reference electrode is the half of the electrode pair which has to maintain a constant potential regardless of solution composition. It should not be easily polarised, possess no temperature hysteresis and a small temperature coefficient.

RELATIVE MILLIVOLTS

A mode in which the actual sensor potential can be displayed. Can be modified to enable a reading to be taken which is relative to some specific point in a measurement cycle.

RESPONSE TIMES

No electrode response, when moving from one solution to another of different strength, is instantaneous. The time taken to achieve a final steady value will vary depending upon such factors as electrode type, degree of concentration change and temperature. Gentle stirring of the solution will improve response times as will agitation of the electrode.

It is normal, under most conditions, for an electrode to reach 90% of its steady state value in less than 30 seconds.

Some instruments have an inbuilt end-point detector which automatically freezes the displayed reading when the electrode signal reaches a pre-determined level of stability.

SALT BRIDGE

The salt bridge is that part of a reference electrode which contains the filling solutions to establish the electrolytic connection between reference internal cell and the test solution.

SELECTIVITY

The ability of an ISE to determine the activity of a given ion in the presence of other ionic species.

SELECTIVITY COEFFICIENT

Defined as the ratio between the activities of the selected ion and an interferent ion which would give an identical electrode response when present in solution.

SINGLE JUNCTION REFERENCE ELECTRODE

Contains a single electrolyte which forms a low-junction-potential liquid junction with the test solution.

SLOPE

An indication of electrode sensitivity. Theoretically an electrode will develop a potential of 59.16mV at 25°C (see Nernst Equation). In practice electrode output might be less than this due to contamination of the sensing membrane. Cleaning will help to restore a Nernstian response. Most pH meters are equipped with a control to enable electrodes to be calibrated when developed potentials are non-Nernstian. (This is often called the 'slope' control).

SOLID STATE ION SELECTIVE ELECTRODE

Membrane is a crystalline solid material; either a single crystal, a homogeneous or a heterogeneous mixture incorporating an inert polymer matrix and the internal electrolyte is replaced with a metal contact pad. No free-flowing liquids are used in the electrode construction which enables the electrodes to be small and insensitive to electrode orientation.

TEMPERATURE EFFECTS

pH measurements are influenced in several ways by temperature. The change in electrode slope described by the Nernst Equation is predictable and is usually corrected for with an ATC probe. Other changes are less predictable and are, therefore, more difficult to correct for. Changes in internal reference potential occur and the pH of samples can vary with temperature.

The impedance of the glass membrane can also cause problems at low temperatures. As a rule of thumb the membrane impedance will double for each 8°C drop below 25°C.

TISAB (TOTAL IONIC STRENGTH ADJUSTMENT BUFFER), (see ISAB also)

The exact formulation which will vary with individual electrode and manufacturer, contains a decomplexing agent, a pH buffer and a species to increase ionic strength.

TITRATION

An analytical technique to measure the concentration of a species by incremental additions of a reagent which complexes or decomplexes the test species. Typically an S-shaped curve of electrode potential against titrant volume is obtained; the equivalent point is at the steepest point of the curve. The technique may be used to directly measure a sample species or indirectly determine an ion not directly sensed by the electrode.

UNITS OF CONCENTRATION

grams per litre (g/l): weight of grams per litre of solvent

parts per million (ppm): milligrams per litre of solvent

moles per litre (mol/l): atomic weight per litre of solvent

ZERO POTENTIAL POINT

The point at which an electrode pair develops a potential of 0mV. This is usually close to 7pH and in many instances is also the isopotential point.

EC Declaration of Conformity

JENWAY Model 3345 Ion Meter complies with the following European Standards:

EN 50081-1:1992 Electromagnetic compatibility - Generic emission standard

EN 50082-1:1992 Electromagnetic compatibility - Generic immunity standard (Performance criterion B)

EN 61010-1:1993 Safety requirements for electrical equipment for measurement, control and laboratory use

Following the provision of:

EMC Directive - 89/336/EEC and Low Voltage Directive - 73/23/EEC



Thank you for reading this data sheet.

For pricing or for further information, please contact us at our UK Office, using the details below.



UK Office

Keison Products,

P.O. Box 2124, Chelmsford, Essex, CM1 3UP, England.

Tel: +44 (0)1245 600560

Fax: +44 (0)1245 600030

Email: sales@keison.co.uk

Please note - Product designs and specifications are subject to change without notice. The user is responsible for determining the suitability of this product.