

# Easidew PRO XP

## Order Codes

### Easidew PRO XP for Gases

To construct the order code, select the relevant feature from the tables below, starting with the base model, which is {Feature A} and then add on options to create a string: {Feature A} + {Feature B} + {Feature C} + {Feature D} + {Feature E} + {Feature F} + {Feature G} + {Feature H}

**Order example:** EA-XP-TX + EX1 + C1 + D2 + E1 + F1 + G1 + H1

Easidew PRO XP Explosion Proof Moisture Transmitter for Gases with no display, stainless steel sintered guard, sample block, no bracket, no material certificates, aluminium housing, -110 to +20°Cdp

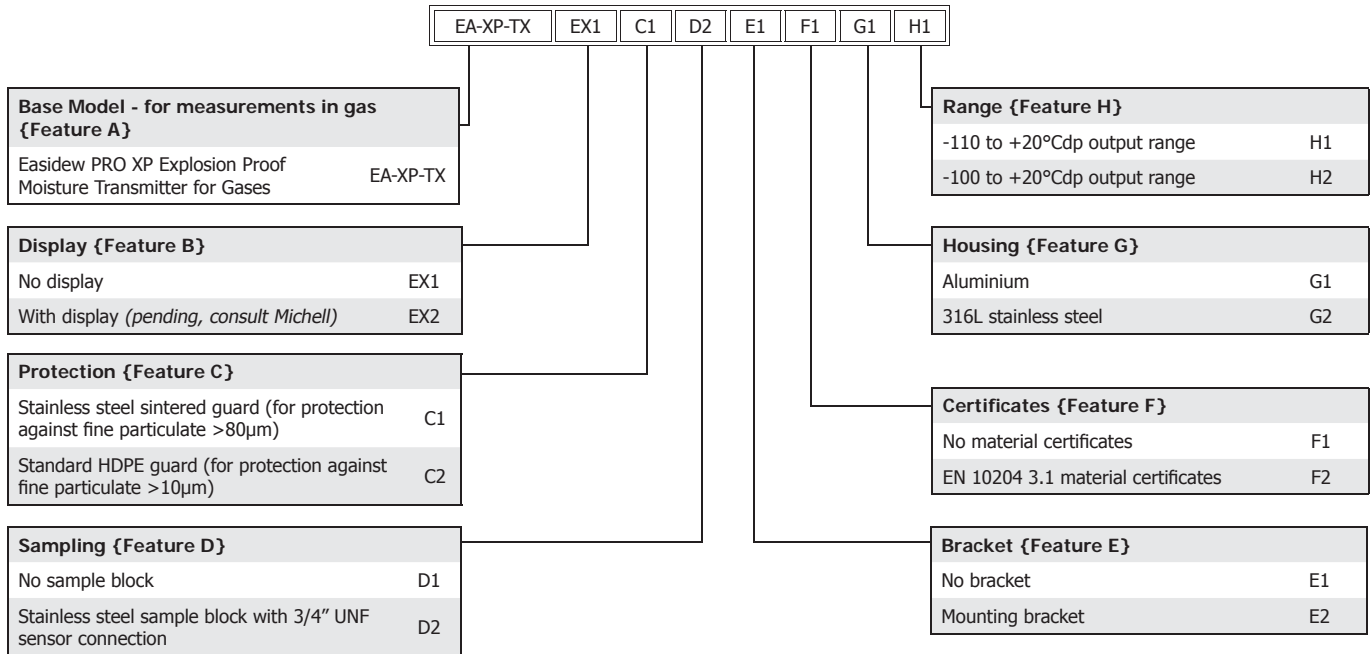

### Easidew PRO XP LQ for Liquids

To construct the order code, select the relevant feature from the tables below, starting with the base model, which is {Feature A} and then add on options to create a string: {Feature A} + {Feature B} + {Feature C} + {Feature D} + {Feature E} + {Feature F} + {Feature G} + {Feature H} + {Feature I}

**Order example:** EA-XP-LQ-TX + EX1 + C1 + D2 + E1 + F1 + G1 + H1 + I01

Easidew PRO XP LQ Explosion Proof Moisture Transmitter for Liquids with no display, stainless steel sintered guard, sample block, mounting bracket, no material certificates, aluminium housing, 0 to 300 ppm<sub>w</sub> for methane

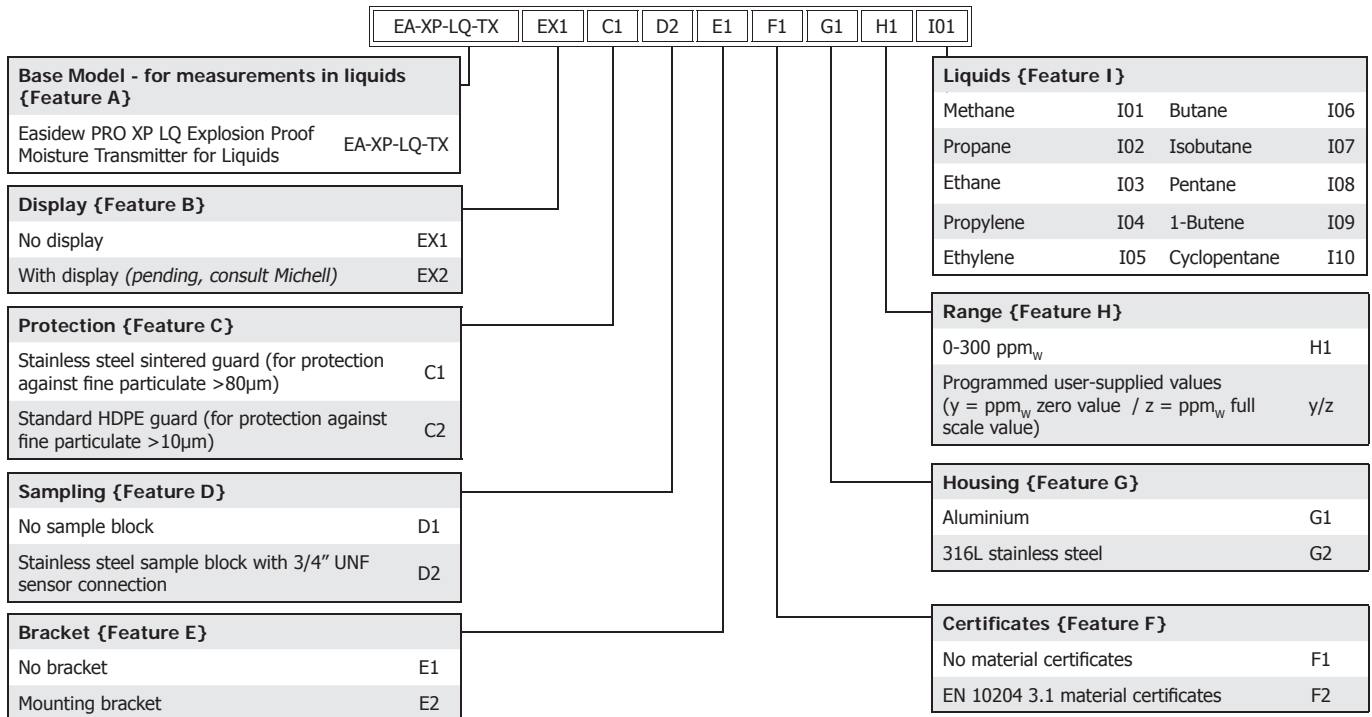

# Easidew PRO XP

## Order Codes

### Accessories and Spare Parts

Mounting bracket	<b>XP-BRK</b>
Stainless steel sintered guard replacement (for protection against fine particulate >80µm)	<b>SSG</b>
Pack of 10 particulate filter cartridges (for protection against fine particulate >25µm (for Sampler Kits))	<b>SSF-PF-10PK</b>
Stainless steel sample block with 3/4" UNF sensor connection	<b>SB-34</b>
Communications kit for Easidew PRO XP (includes XP-CK-ADT adapter)	<b>XP-CK</b>

### Services

Re-calibration of Easidew PRO XP. (Standard/Non-Standard - Supplied with traceable calibration certificate)	<b>XP-Recal</b>
Re-calibration of Easidew PRO XP LQ. (Standard/Non-Standard - Supplied with traceable calibration certificate)	<b>XP-LQ-Recal</b>



Thank you for reading this data sheet.

For pricing or for further information, please contact us at our UK Office, using the details below.



**UK Office**

**Keison Products,**

**P.O. Box 2124, Chelmsford, Essex, CM1 3UP, England.**

**Tel: +44 (0)330 088 0560**

**Fax: +44 (0)1245 808399**

**Email: [sales@keison.co.uk](mailto:sales@keison.co.uk)**

Please note - Product designs and specifications are subject to change without notice. The user is responsible for determining the suitability of this product.