

GD10

GD10P (UL) IR Point Gas Detector

Fast reliable response
No field recalibration
Solid state IR-source

The Simtronics GD10P detector is the benchmark for combustible gas detection on offshore installations. It has set the standard for gas detectors in the areas of safety, stability and low maintenance. GD10P comes with 5 years warranty.



The GD10P has been designed with features that provide an effective response to the detection of gas hazards in a wide range of industrial environments from boiler plant rooms to offshore petrochemical installations.

These infrared gas detectors differ from all other models, because they utilise silicon based solid-state infrared sources. The complete optomechanical design and construction is so stable that an ultra fast speed of response can be achieved whilst providing unparalleled service life and detector stability, thus saving on maintenance and service costs.

We offer the longest combined detector and IR source warranty on the market.

For retrofit applications, a bridge interface is available allowing the detector to be connected directly to catalytic systems, using the existing cabling and control modules.

Supplied with worldwide performance (CSA / CENELEC) and hazardous area approvals. Suitable for use in SIL 2 and SIL 3 systems.

An industry standard HART interface is used for configuration of the optional fast response time and special fault levels as well as access to extended maintenance data.

Features

Solid state IR sources (SimSource™)

High IR source flash rate

True dual path, double compensation optical design

Selectable response rate

Dual layer weather protector

Early dirty optics warning

Low power consumption

Independently heated mirror and lens

Benefits

Superior long term performance compared to filament lamps

Improved stability and speed of response

No recalibration, monitors and accounts for all changes in optical path

Fastest IR point detector on the market, ideal for speed critical applications

No mesh, gauze, hydrophobic filters or sinters = No delay, no failure on demand

Improved preventative maintenance

Reduces load on UPS

High performance detection in rough environmental conditions

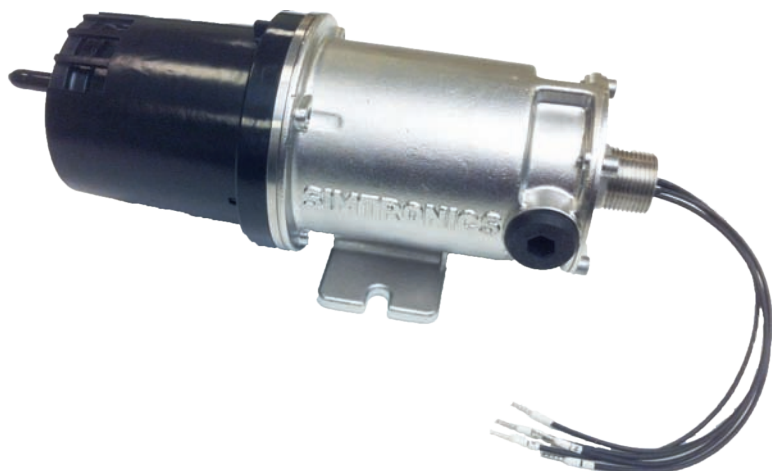

GD10P (UL)

Technical Data

GENERAL

Detection method	IR-absorption, dual wavelength, dual path
IR-Source	Solid state IR source, 50Hz flash
Gases detected	Hydrocarbons and CO ₂
Self-test	Continuous
Calibration	Factory set, no field recalibration

PERFORMANCE

Lifetime stability *)	±5% of full scale (FS) reading
Accuracy *)	±3% FS between 0-50 % reading ±5% FS between 50-100 % reading
Response time	T20 = 1 sec. (Option 0.3 sec) T50 = 2.5 sec. (Option 0.7 sec) T90 = 6 sec. (Option 1.6 sec)
Start-up time *)	Less than 60 sec. *) Refers to -20°C to + 45°C

OUTPUT SIGNAL

Standard	Current source 4 – 20 mA, max. load impedance 500 Ohm
Option	Current sink 4 – 20 mA
HART®	Maintenance and configuration
Detector warnings:	Configurable (HART)
- Early clean optics	Pre warning (2 mA)
- Dirty optics	Dirt accumulation (1 mA)
- Detector failure	Internal fault (0 mA)

ELECTRICAL

Power supply	24 V DC, range 18-32 V DC
Power consumption	Approx. 3.5 W
Electrical connection	5 wire flying lead (22AWG) for wiring into termination box.
Conduit connection	1 x 3/4" NPT (M).

TEMPERATURE RANGE

Storage	-40°C to + 70°C (-40°F to +158°F)
Operating	-40°C to + 65°C (-40°F to +149°F)
Humidity (operation)	99% RH (non condensing)

EXPLOSION PROOF HOUSING

UL Rating	Class 1 Div 1, Group C&D
Protection category	NEMA4X (IP67 DIN 40050)
Housing material	Stainless steel SIS2343 (ASTM 316)
Weight	Approx. 2.9 kg (6.4 Lbs)
Dimensions (LxWxH)	251 x 104 x 105 (mm) 9.89 x 4.1 x 4.13 (inches)

WARRANTY

5 years full warranty on complete detector
15 years warranty on the IR-sources

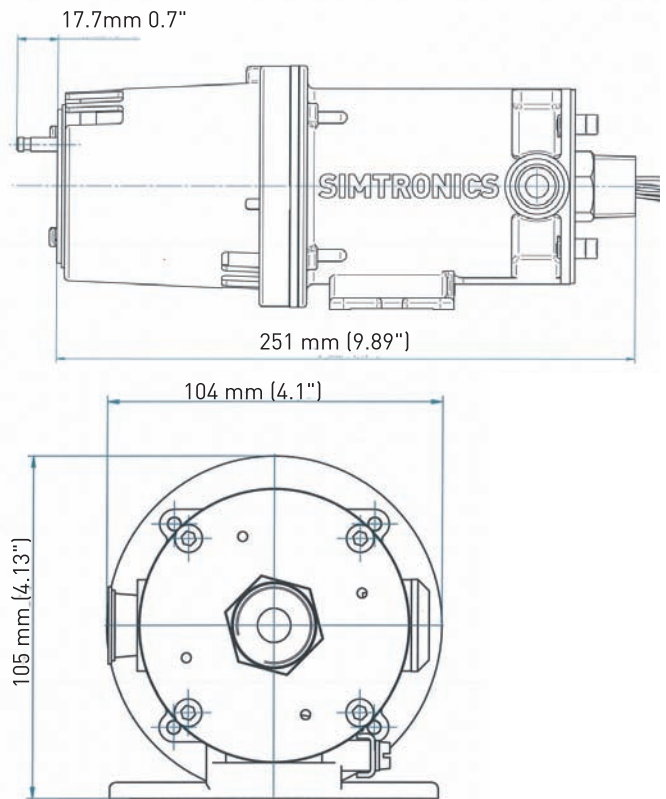

APPROVALS

UL Certificate Number	E219548
SIL	Qualified for SIL2 and SIL3 systems

VERSIONS

Gas	Ranges
Methane	0-100%LEL, 0-100%Vol
Propane	0-100%LEL
Other versions are available, please contact your dealer.	

FRONT COVER

Required, select one	
- Weather protection	For standard point detector
- Sample flow housing	For sampling systems and testing
- Duct mount kit	For through wall installation

ACCESSORIES

Mosquito net	Extra insect protection
Sun shade	Shielding for extreme radiation exposure



Thank you for reading this data sheet.

For pricing or for further information, please contact us at our UK Office, using the details below.



UK Office

Keison Products,

P.O. Box 2124, Chelmsford, Essex, CM1 3UP, England.

Tel: +44 (0)330 088 0560

Fax: +44 (0)1245 808399

Email: sales@keison.co.uk

Please note - Product designs and specifications are subject to change without notice. The user is responsible for determining the suitability of this product.