

---

**TECHNE**

# Sample Concentrator

**OPERATOR'S MANUAL**

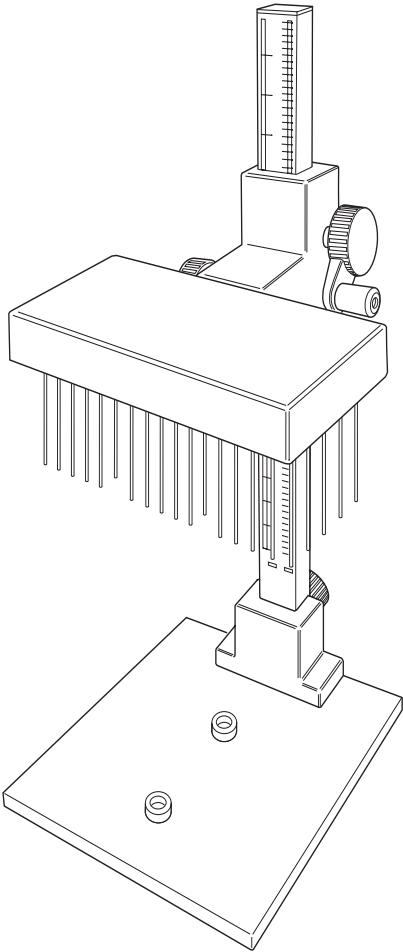

**CONTENTS**

	<b>PAGE</b>
<b>INTRODUCTION</b>	2
Warning	2
Operator safety	3
Specification	3
Installation	3
Diagram of Sample Concentrator	4
Guarantee	5
<b>OPERATION</b>	6
Preparation	7
Operation	8
<b>ADDITIONAL INFORMATION</b>	9
User maintenance	9
Solvent evaporation temperatures	10
Diagram of gas chamber	12
Replacement parts	13

## INTRODUCTION

Please read all the information in this user manual before using the Sample Concentrator.

The Techne Sample Concentrator has been designed to provide a quick and convenient method of accelerating the concentration by evaporation of solvents from samples prior to analysis. It is designed to work in conjunction with Techne DB-3, DB-3A or DB-3D Dri-Block® heaters\*.

The Sample Concentrator consists of a gas chamber mounted above a Dri-Block® heater into which vessels containing samples are placed. Hyperdermic needles carry the gas down from the chamber into the test tubes. The samples are heated from below by the heater and the flow of gas directed over the surface of the samples displaces the evaporated solvent from above the liquid's surface. This significantly increases the rate of sample concentration.

The unit provides accurate and reproducible control over the positioning of the needles. The gas chamber can be removed from its stand to provide easy access to the samples, and it can be replaced quickly. The whole unit is compact enough for convenient use in a fume cupboard.

### WARNING

HIGH TEMPERATURES ARE DANGEROUS: they can cause serious burns and ignite combustible material. Users should pay attention to the following points:

- USE CARE AND WEAR PROTECTIVE GLOVES TO PROTECT HANDS;
- DO NOT put hot objects on or near combustible objects;
- DO NOT place any liquid directly into your Dri-Block® heater;
- At all times USE COMMON SENSE.

*\*The Dri-Block® heater is not provided and must be purchased separately.*

## SAFETY ADVICE BEFORE USE

### OPERATOR SAFETY

All users of Techne equipment must have available the relevant literature needed to ensure their safety.

It is important that only suitably instructed personnel operate this equipment, in accordance with the instructions contained in this manual and with proper safety standards and procedures.

### SPECIFICATION

Maximum vertical travel	320 mm
Maximum gas pressure	2 psi
Maximum gas usage	15 litres/min
Gas	Any inert gas (often nitrogen)
Needle positions	Variable to suit Techne Dri-Blocks®
Gas Intake Nozzle Diameter	6.35 mm (1/4")
Height	530 mm
Width	240 mm
Depth	295 mm
Weight	3.5 Kg

### INSTALLATION

For packing purposes the Sample Concentrator is supplied unassembled in three parts; the base board, the column and carriage, and the gas chamber. The unit is re-assembled as follows:

1. Unscrew the column fastening knob from the column support bracket already fixed to the base board. Locate the column on the two pins in the support bracket. Screw the fastening knob through the rear of the column and tighten firmly.
2. Insert the locating pin on the rear of the gas chamber into the front of the carriage aligning the indent in the chamber with the positioning pin on the carriage. Tighten the locking knob.

## DIAGRAM OF SAMPLE CONCENTRATOR

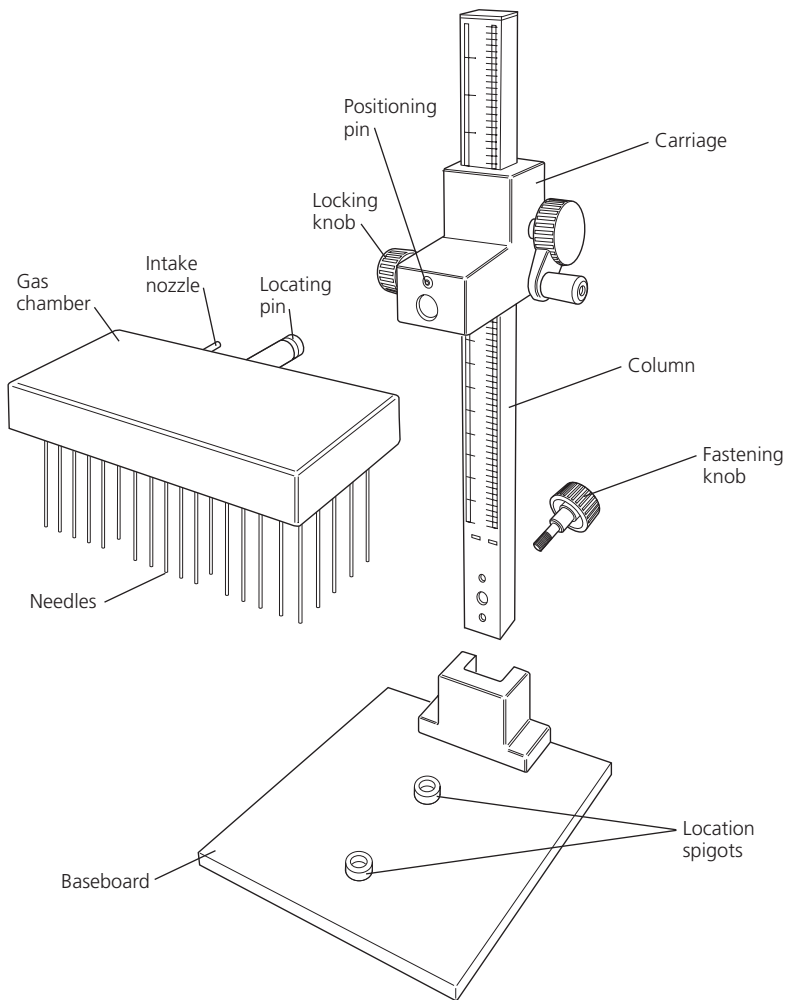

3. Connect the intake nozzle at the rear of the gas chamber to a suitable supply of gas via a pressure reducing valve. The gas pressure should be adjusted as required at the reducing valve but should not exceed 2 psi. Pressure in excess of 2 psi will cause gas to be vented and wasted.
4. Place the Techne Dri-Block® heater onto the base of the Sample Concentrator. It is positioned by means of two spigots on the base board which align with two centrally located screw heads on the underside of the Dri-Block® unit.

## GUARANTEE

This instrument is guaranteed against any defect in material or workmanship for a period as specified on the enclosed guarantee card. This period is from the date of purchase, and within this period all defective parts will be replaced free of charge provided that the defect is not the result of misuse, accident or negligence. Servicing under this guarantee should be obtained from the supplier.

Notwithstanding the description and specification(s) of the units contained in the user manual, Techne hereby reserves the right to make such changes as it shall see fit to the units or to any component of the units.

This user's manual has been prepared solely for the convenience of Techne customers and nothing in this manual shall be taken as a warranty, condition or representation concerning the description, merchantability, fitness for purpose or otherwise of the units or the components.

## OPERATION

### Preparation

1. Place the aluminium insert blocks to be used into the Dri-Block® unit. The blocks should touch each other and be positioned centrally.
2. Loosen the locking knob on the carriage. Remove the gas chamber, disconnecting the gas pipe if necessary, and lay the chamber upside down on a suitable work surface.
3. Insert the hyperdermic needles in the pattern to suit the test tubes to be placed in the heater.

The needle guide holes are labelled with a letter corresponding with the type of insert block used in the heater. These are listed in the following table. As an example if you use the block for twelve 15mm test tubes (block number F3506) you would place a needle in all the holes labelled C and all holes labelled D.

Only Sample Concentrators with the part number FSC496D or a replacement head part number 6104202 will have the 96 well array.

<i>Tube size &amp; number</i>	<i>Insert block number</i>	<i>Hole label</i>
6mm x 30	F3502	A
10mm x 20	F3503	B
12mm x 20	F3504	B
13mm x 20	F3505	B
15mm x 12	F3506	C & D
16mm x 12	F3507	C & D
19mm x 8	F3508	D, E & F
25mm x 6	F3509	D & E
9mm x 10	F4461	A
7mm x 20		
24mm x 6	F4462	D & E
26mm x 6	F4463	D & E
1.5ml x 20	F4464	B
0.5ml x 30	F4465	A

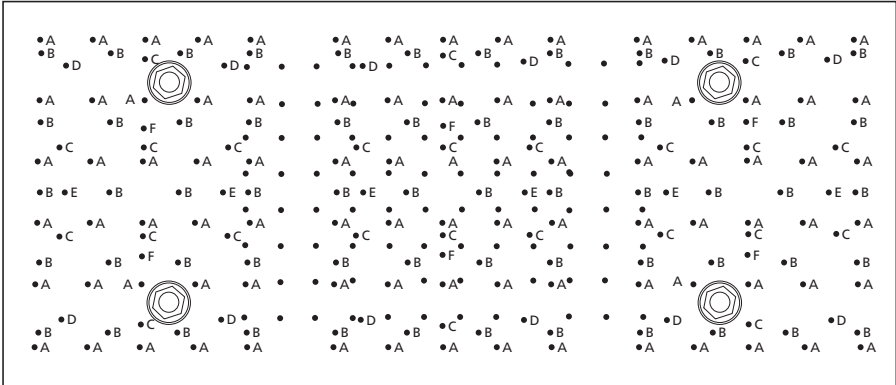

**96 well hole array (12 x 8 matrix as above)**

Press each needle firmly, pointed end first, through the guide holes and through the sealing pad behind so that it is held firmly in position. Build up the desired pattern of needles to suit the arrangement of test tubes to be used. Do not put a needle in any position which will not have a corresponding sample to be concentrated as this will only waste gas. The needles may be removed and replaced many times as the pad is self sealing.

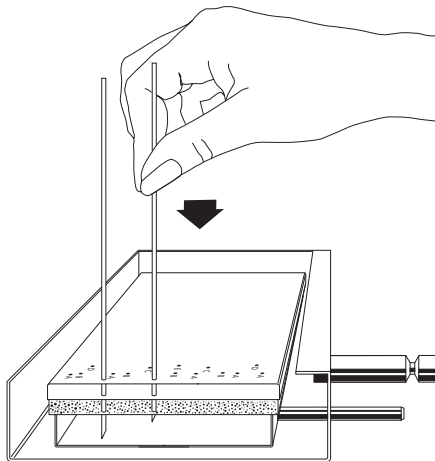

**INSERTING THE NEEDLES**

4. Replace the gas chamber onto the carriage and tighten the locking knob. Re-connect the gas pipe if necessary.

## PROCESSING OF SAMPLES

**Warning** - remember high temperatures are dangerous. The heater, insert blocks, sample vessels, needles and samples may be very hot. Always take the precautions listed earlier in this manual.

1. By turning the carriage handle, on the right hand side, counter clockwise raise the gas chamber to take the needles well away from the heater.
2. Place the sample vessels in the insert blocks and lower the chamber so that the tips of the needles enter the test tubes. Position them at the required height above the liquid surface.
3. Set the heater to the required temperature and adjust the gas flow to the desired rate. Remember not to exceed 2 psi.
4. To increase the rate of concentration the chamber may be lowered as evaporation takes place so that the needles follow the level of the samples in the tubes. Using the scale on the column fine adjustments are easily made.
5. On completion switch off the gas flow and raise the chamber out of the way.
6. For operation of the Dri-Block® see the user's manual supplied separately.

## ADDITIONAL INFORMATION

### User maintenance

#### 1. Cleaning

Your Sample Concentrator can be cleaned by wiping with a cloth dipped in soapy water. Ethanol and formaldehyde may also be used. Do not use abrasive cleaners.

#### 2. Carriage friction

Height adjustment is by means of a friction drive. To allow for wear the friction pressure may be increased by tightening the 4 screws on the rear of the carriage sufficiently to give adequate grip. Ensure that all four are tightened equally.

#### 3. To replace the sealing pad

After many repeated needle insertions the self sealing property of the sealing pad may start to degrade. Spare pads can be obtained from your supplier or from Techne. Replacing the pad is simply accomplished as follows:

- Remove the gas chamber from the carriage, disconnect the gas pipe and place upside down on a suitable work surface.
- Remove the four nuts securing the matrix plate.
- Lift off the matrix plate leaving the four spacers in position.
- Lift off the sealing pad. Ensure that the support strip underneath the sealing pad and the four spacers remain in place.
- Replace the sealing pad with the new one. Reassembly is the reverse of the above procedure.

For any other servicing requirements please contact your supplier or Techne's service department.

## SOLVENT EVAPORATION TEMPERATURES

IUPAC Name	Common Name	Boiling point (°C) at 1013 mbar pressure	Pressure (mbar) at which b.p is 40°C
2-propanone	Acetone	56	556
1-pentanol	Pentyl alcohol	137	11
Benzene	Benzene	80	236
1-butanol	Butyl alcohol	118	25
2-methyl-2-propanol	Tert-butyl alcohol	83	130
Chlorobenzene	Chlorobenzene	132	36
Chloroform	Trichloromethane	61	474
Cyclohexane	Cyclohexane	81	235
Ethoxyethane	Diethyl ether	35	Atmospheric
1,2-dichloroethane	Ethylene chloride	83	210
1,2-dichloroethene	Cis-acetylene dichloride	60	479
1,2-dichloroethene	Trans-acetylene dichloride	48	751
2-propan-2-yloxypropane	Isopropyl ether	68	375
1,4-Dioxane	Diethylene oxide	101	107
N,N-dimethylformamide	Dimethylformamide (DMF)	153	11
Acetic acid	Ethanoic acid	118	44
Ethanol	Alcohol	79	175
Ethyl acetate	Ethyl ester	77	40
Heptane	Dipropylmethane	98	120
Hexane	n-hexane	69	335
Propan-2-ol	Isopropanol	82	137
3-methyl-1-butanol	Isoamyl alcohol	130	14
Butan-2-one	Methylethylketone (MEK)	80	243

## SOLVENT EVAPORATION TEMPERATURES

### continued

<b>IUPAC Name</b>	<b>Common Name</b>	<b>Boiling point (°C) at 1013 mbar pressure</b>	<b>Pressure (mbar) at which b.p is 40°C</b>
Methanol	Methyl alcohol	65	337
Dichloromethane	Methylene chloride	40	Atmospheric
Pentane	Pentane	36	Atmospheric
Propan-1-ol	Propyl alcohol	97	67
1,1,1,2,2-pentachloroethane	Pentachloroethane	162	13
1,1,2,2-tetrachloroethane	Tetrachloroethane	138	35
1,1,1-trichloroethane	Trichloroethane	75	271
Tetrachloromethane	Carbon tetrachloride	76	300
1,1,2,2-tetrachloroethene	Tetrachloroethylene	121	53
Oxolane	Tetrahydrofuran (THF)	67	357
Toluene	Methylbenzene	111	77
1,1,2-trichloroethene	Trichloroethylene	87	183
Oxidane	Water	100	72
Dimethylbenzene	Xylene (mixed)	137	25
1,2-dimethylbenzene	o-xylene	144	34
1,3-dimethylbenzene	m-xylene	139	25
1,4-dimethylbenzene	p-xylene	138	31

### DIAGRAM OF GAS CHAMBER

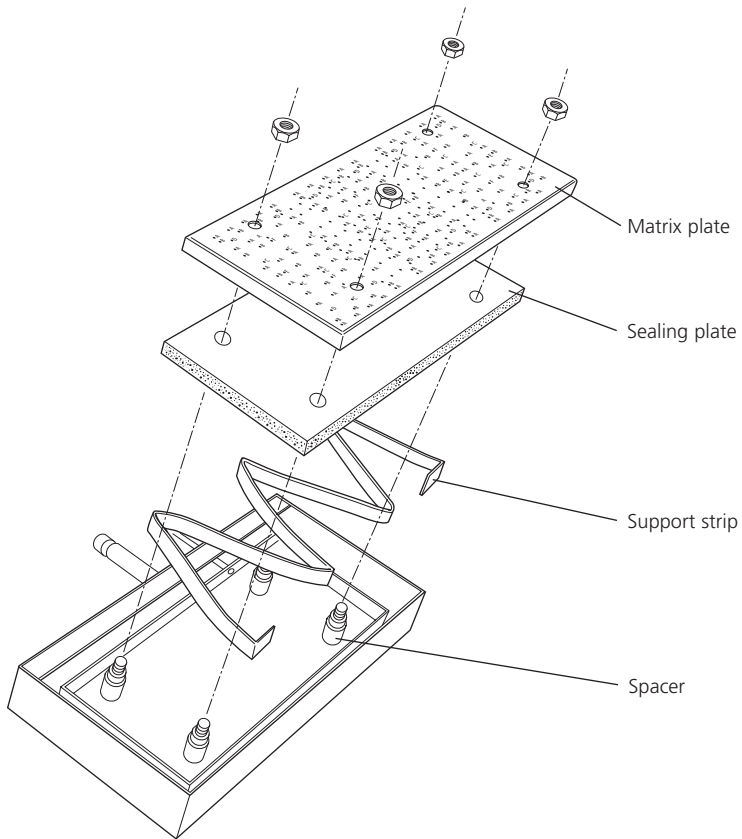

## REPLACEMENT PARTS AND ACCESSORIES

The following replacement parts and accessories may be obtained from your supplier or from Techne.

<i>Part Number</i>	<i>Description</i>
F7209	Pack of 100 x 76mm long needles
F7210	Pack of 100 x 127mm long needles
FSC4NCS	Pack of PTFE coated needles, 100 x 76mm long
FSC4NCL	Pack of PTFE coated needles, 100 x 127mm long
6101609	Base board
6101608	Spigot
6101604	Sealing pad
6101606	Spacer
6101605	Support strip

### **Spare and alternative heads complete**

6010080	Standard, three block, matrix head
6104202*	96 well holes added to standard matrix
6103824	96 well head off-set for automatic machine

### **Concentrators with various heads**

FSC400D	Standard, three block, matrix
FSC496D*	96 well lay-out added to standard matrix

\* Can be used with standard blocks or 96 well block but is not easy to differentiate for needle insertion



Thank you for reading this data sheet.

For pricing or for further information, please contact us at our UK Office, using the details below.



**UK Office**

**Keison Products,**

**P.O. Box 2124, Chelmsford, Essex, CM1 3UP, England.**

**Tel: +44 (0)1245 600560**

**Fax: +44 (0)1245 600030**

**Email: [sales@keison.co.uk](mailto:sales@keison.co.uk)**

Please note - Product designs and specifications are subject to change without notice. The user is responsible for determining the suitability of this product.