

**Multi-Spectrum Digital
Electro-Optical Fire Detectors**

MODEL SS3

(Models SS3-A, SS3-AN, SS3-AB, and SS3-ABN)

STAND-ALONE MODE or FS2000 SYSTEM MODE

**Installation Guide
and
Operating Manual**

Read and understand this manual before installing or operating equipment.

No part of this document may be copied or reproduced without the express written permission of Fire Sentry Corporation (FSC).

This manual is subject to change without notice.

ACCTTL, ALERT-1, ALARM-2, ALERT-1: ALARM 2, ALERT-1: ALARM-2, ATAG, Clean Room Sentry, COP-i, Complete Optical Path Integrity, CM1, CM1-A, DartLogic, FireLogic, Fire Signature Analysis, FireBusI, FireBusII, FirePic, FirePicII, FirePicIII, FirePix, FirePicture, FSC, Fire Sentry Corporation, Fire Sentry Corp., FSX, All FSX Nomenclature Variations (such as: FS2, FS2X, FS3, FS3X, FS4, FS4X, FS5, FS5X, FS6, FS6X, FS7, FS7X, FS8, FS8X, FS9, FS9X, FS10X, FS10X, FS11, FS11X, FS12, FS12X, FS14, FS14X, FS15, FS15X, FS16, FS16X, FS17, FS17X, FS18, FS18X, FS19, FS19X, FS20, FS20X, FS24, FS24X, FS24XN, FS26, FS26X, FS26XN), FS7-2173-2RP, FS System 7, FS System 10, FS7-2173, FS7-2173-RP, FS2000, FS System 2000, High Speed Flame & Surveillance Detector, Multi-Spectrum QuadBand Triple IR, Multi-Spectrum TriBand, Multi-Spectrum Tri-Band, Near Band Infrared, Near Band IR, NearBand IR, QuadBand IR, Room Sentry, RS, RS2, SM2, SM3, SS, SS2, SS2X, SS2-A, SS3, SS3-A, SS3X, SS4, SS4-A, SS4X, SnapShot, SLR-BIT, SuperBus, SuperSentry, System 2000, Tri-Mode Plot, QuadBand Triple IR Plus, TriBand, Tri-Band, "FS & FSC triangle logo's", WBIR, Wide Band Infrared, WideBand IR, Wide Band IR

are Trademarks of Fire Sentry Corporation (FSC), Yorba Linda, California.

©Copyright 1998 - 2009 by Fire Sentry Corporation (FSC)



SS3-A, SS3-AN, SS3-AB, SS3-ABN

Electro-Optical Fire Detectors

Installation and Operations Guide

TABLE OF CONTENTS

	PAGE
SECTION 1 FAMILIARIZATION	1
1.1 Introduction	1
1.2 Stand-Alone Operation	1
1.3 FS2000 System Operation	1
1.4 Overview	1
1.4.1 Model SS3 Detector	1
1.4.2 Testing	1
SECTION 2 INSTALLATION	2
2.1 Installation Procedure	2
2.1.1 Installation Precautions	2
2.1.2 Device Layout	2
2.1.3 Wiring Recommendations	2
2.1.4 Power Supply Considerations	2
2.2 Detector Installation	2
2.3 Wiring Detectors	2
2.3.1 Wiring as Standalone	3
2.3.2 Wiring to FS2000 (FireBus)	3
2.3.3. Wiring the Fire Relay	3
SECTION 3 MAINTENANCE AND TROUBLESHOOTING	5
3.1 Personnel	5
3.2 Cleaning Windowed Enclosures and Detectors	5
3.3 Model SS3 Detector	5
3.4 Detector Repair	5
SECTION 4 DETECTOR DATA	6
Table 1: Model SS3 Detector Connectors - Pinouts	6
Mechanical Layouts	7
Model SS3 Detector Mounting Brackets	7
Model SS3-A and SS3-AN Detectors	8
MODEL SS3-AB AND SS3-ABN DETECTORS	8
INDEX	9

SECTION 1 FAMILIARIZATION

1.1 Introduction

The **Model SS3** Optical Fire/Flame Detectors operate the **SAME** whether they are connected to the FS2000 Fire Early Warning System (with FS2000 Controller and FireBus) or whether they operate in the Stand-Alone configuration. When the Model SS3 Detectors are connected to the FS2000 System, refer to the Fire Sentry Corporation document MN0003 entitled "FS2000 FIRE EARLY WARNING SYSTEM - INSTALLATION and OPERATIONS GUIDE". The **only** difference between FS2000 System Model SS3 Detectors and a Stand-Alone SS3 Detectors is how each is wired. Sections 1.2 and 1.3 below explain the wiring differences.

The SS3 products consist of the **Models SS3-A, SS3-AN, SS3-AB and SS3-ABN**. Each detector is housed in an ABS white plastic enclosure. The cost-effective Model SS3 fire detector products were designed for indoor applications and applications where a low profile detector is preferred.

The Model **SS3-A** and **SS3-AN** are Multi-Spectrum Optical Fire Detectors which utilize the wide band infrared (IR), visible (VIS), and ultraviolet (UV) spectral bands. The **SS3-A** uses a latching relay and the **SS3-AN** has a NON-latching relay and auto resets. Both feature a wide 120 degree field of view.

The Model **SS3-AB** and the **SS3-ABN** are Ultraviolet (UV) Optical Fire Detectors which feature a wide 180 degree field of view back-facing UV sensor for use in enclosed areas such as wet stations or gas cabinets. The **SS3-AB** uses a latching relay and the **SS3-ABN** uses a NON-latching relay and auto resets.

1.2 Stand-Alone Operation

For Stand-Alone operation, the Model SS3 Detectors may be connected to a FM/UL Approved Fire/Security Panel. The Model SS3 Detector operates on 24 volts DC. The Model SS3 Detector, when operated in the Stand-Alone mode, uses its Fire relay to interface to FM/UL Approved Fire /Security Panels

1.3 FS2000 System Operation

For FS2000 System operation, the Model SS3 fire signals are sent digitally to the FS2000 System Controller using the four wire FS2000 FireBus. The FireBus provides the 24 volts DC power for the Model SS3 Detector and RS-485 digital communication (Refer to Fire Sentry document MN0003 entitled "FS2000 FIRE EARLY WARNING SYSTEM - INSTALLATION and OPERATIONS GUIDE"). For special remote alarm applications, users may connect directly to the Model SS3's Fire relay connector.

1.4 Overview

1.4.1 Model SS3 Detector

The Model SS3 Detectors are micro-computerized devices. The Detectors' logic "brain" alarms to fires quickly.

There is one LED on the Model SS3 Detectors that indicate the state of the Detector. If the LED blinks approximately every 10 seconds, then the Detector is in Normal Operation

When a Model SS3 Detector alarms to a fire, it energizes its Fire relay and turns on its red LED.

1.4.2 Testing

The Model SS3 Detectors contain an internal monitoring circuits for self-testing. For testing the Model SS3-A and SS3-AN Detectors end-to-end for both optical path and window cleanliness, use a Fire Sentry Model DD85001 UV/IR Test Lamp. The Model SS3-AB and SS3-ABN can be tested using the Model 85001 and Model 85001(B) UV testers.

SECTION 2 INSTALLATION

2.1 Installation Procedure

This section describes the installation of the Model SS3 Detector for the Stand-Alone mode. It is recommended that junction boxes be used to wire the Model SS3 Detectors..

2.1.1 Installation Precautions

The following precautions should be observed during installation of Model SS3 Detectors.

Double-check to make sure that the external electrical power is turned OFF before connecting to the Model SS3 Detector.
--

2.1.2 Device Layout

Model SS3 Detectors should be located to cover the specific "fire threat" areas. The Model SS3-A and SS3-AN Multi-Spectrum Detectors' field of view is 120° with a range of 30 feet to an industry-standard one square foot Type B gasoline pan fire. In area coverage applications the Detectors should be located with overlapping fields of view to insure complete coverage of the area. Detectors should also be located away from strong RF (Radio Frequency) sources. The Model SS3-AB and SS3-ABN UV Fire Detectors are designed for enclosed areas and feature a wide 180° field of view.

2.1.3 Wiring Recommendations

Fire Sentry Corporation recommends using junction boxes to help prevent problems with intermittent connections. Install a junction box near each Model SS3 Detector location. Next, wire each Model SS3 Detector to its junction box. Use screw-down terminal strips inside the junction box to make the connections to the Detector's terminals and a UL/FM Approved Fire Alarm Panel. Use UL/FM Approved junction boxes and terminal strips.

Avoid wire splices. However, if wire splices are necessary, Fire Sentry Corporation recommends soldering all splices. The use of good wiring practices will greatly improve the ease of installation, improve reliability, and allow easier servicing.

2.1.4 Power Supply Considerations

The Model SS3 Detectors use 12 or 24 volts DC at a maximum current of 40 milliamps. Make sure that the Panel's power supply can handle the current load of the total number of Model SS3 Detectors connected to it. For example, if 10 each Model SS3 Detectors are used on one Panel's power supply, (multiply 10 times 40 milliamps), the Panel's power supply must be able to handle at least 400 milliamps. This current load must also be considered when calculating the Panel's power backup requirements for 24 hour backup.

2.2 Detector Installation

Although not required, Fire Sentry Corporation recommends using the Mounting Bracket when installing the Model SS3 Detector to a wall or junction box.

- a. Choose fasteners for the bracket that will secure it solidly to the type of material at the enclosure location.
- b. Mount the bracket to the wall.
- c. Install the Model SS3 Detector enclosure onto the bracket

2.3 Wiring Detectors

The Model SS3 Detector may be wired for use on the FS2000 System or to another Control Panel in the Standalone configuration. Regardless of which type of Controller or System the Detector is wired to the Fire Relay will function the same. There are several ways to wire the Fire Relay to a Control Panel or Initiating Circuit. See the manual for the control panel you will be using for specific wiring information.

SS3-A, SS3-AN, SS3-AB, SS3-ABN Electro-Optical Fire Detectors Installation and Operations Guide

2.3.1 Wiring as Standalone

Connect the 24 volt DC Power Supply wires into the connector and firmly tighten down the slotted screws with a small screwdriver. **DO NOT CONNECT ANY WIRES TO J1 - Pin 2 or J1 - Pin 3.** Do NOT over tighten or the screws may strip or break. Refer to Figure 4, Model SS3 Detector Wiring.

Pin 1	Pin 2	Pin 3	Pin 4
Black	Green or Blue	White or Yellow	Red
GROUND (-)	NOT USED	NOT USED	POWER (+)

2.3.2 Wiring to FS2000 (FireBus)

Connect the FireBus Cable wires into the connector and firmly tighten down the two slotted screws with a small screwdriver. Do NOT over tighten or the screws may strip or break. Refer to Figure 4, Model SS3 Detector Wiring.

Pin 1	Pin 2	Pin 3	Pin 4
Black	Green or Blue	White or Yellow	Red
GROUND (-)	FIREBUS (RX)	FIREBUS (TX)	POWER (+)

2.3.3. Wiring the Fire Relay

For Stand-Alone or FS2000 systems: Connect the initiating circuit wires to the four pin WECO terminal. Install the wires into Pins 7 and 8 (for **Normally Open** relay) or Pins 6 and 7 (for **Normally Closed** relays) and firmly tighten down the slotted screws with a small screwdriver. There is an internal 10K ohm resistor between Pins 5 and 6 for circuits which require an End of Line (Supervision) resistor. One common configuration is to Jumper Pins 5 to 8 and connect the initiating circuit to Pins 7 and 8.

Refer to Figure 4, Model SS3 Detector Wiring, for more details on relay connections.

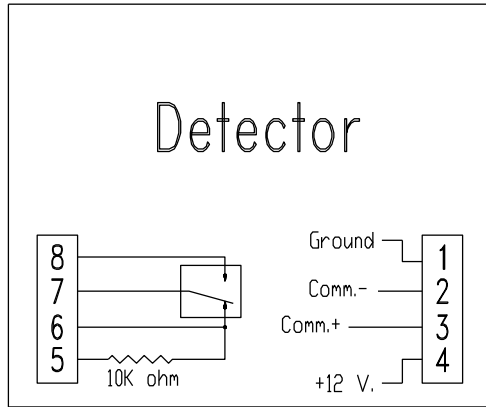

Internal Wiring Diagram

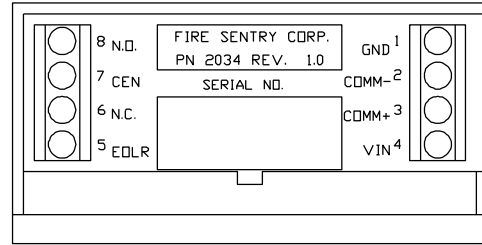

Inside Connector Compartment

Figure 1

Model SS3 Detector Connection Diagrams

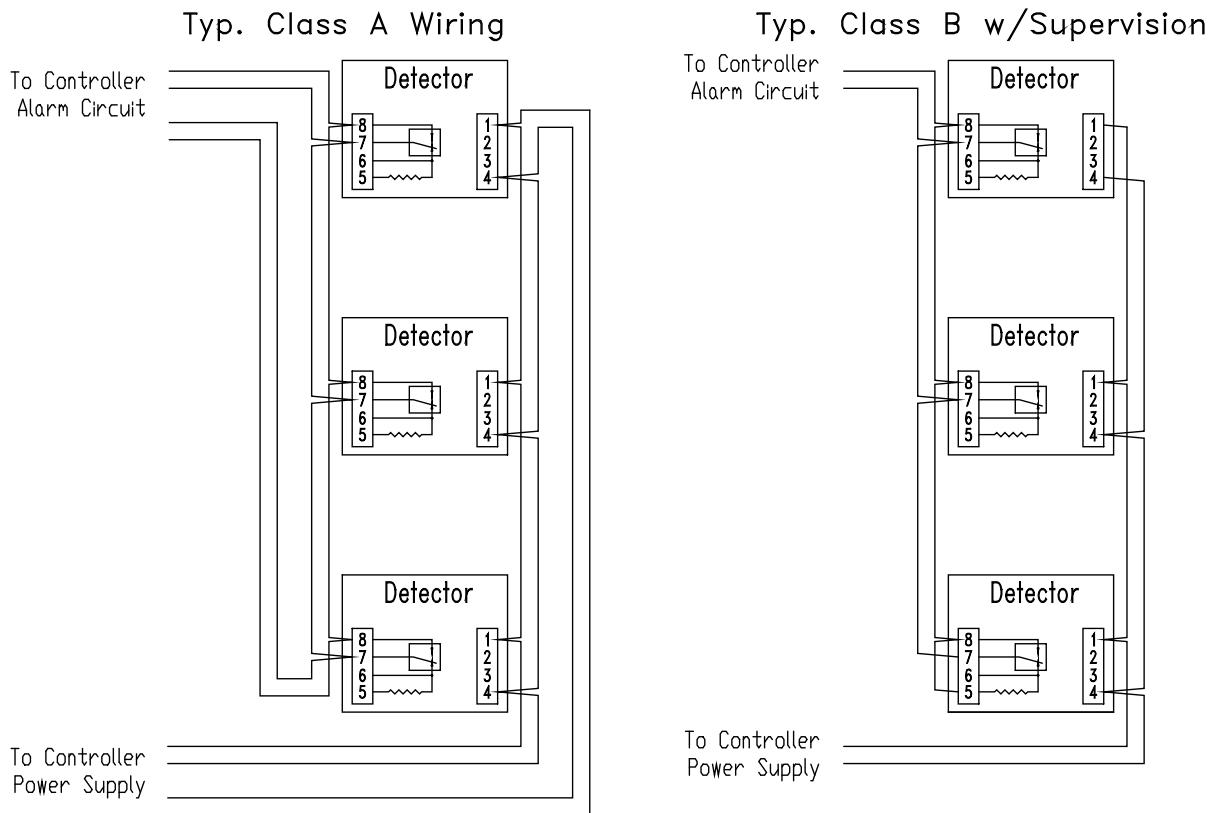

Figure 2

Model SS3 Detectors Wiring

SECTION 3

MAINTENANCE AND TROUBLESHOOTING

3.1 Personnel

The following will aid in troubleshooting the Model SS3 Detectors. Tests must be performed by qualified authorized personnel observing standard safety practices. Although the Model SS3 Detector operates on safe 24 volts DC, the FM/UL Approved Fire Alarm Panel's power supply may operate on a dangerous 120 or 240 volts AC.

WARNING: Hazardous voltages may be present during testing procedures. Serious injury or death may result if personnel fail to observe safety precautions.

3.2 Cleaning Windowed Enclosures and Detectors

The optical windows on the Model SS3 Detector should be cleaned periodically on a regular maintenance schedule. For clean applications, this may be every month. However, for extremely dirty applications a cleaning schedule of every day may be necessary.

Clean the windows on the Model SS3 Detectors whenever they are handled, whenever the windows look dirty, or whenever the Model SS3 Detector fails to pass an end-to-end test with a Handheld Tester.

Use a blast of an air hose or an oil-free cloth to clean the enclosure windows. Oil degrades the performance of UV detectors. Occasionally, the use of a solvent such as alcohol may be required. No disassembly of the Model SS3 Detector is required.

DO NOT USE SILICONE-BASED OR COMMERCIAL WINDOW CLEANING PRODUCTS. THEY WILL DEGRADE THE MODEL SS3 DETECTOR PERFORMANCE.

3.3 Model SS3 Detector

CAUTION: Model SS3 Detectors are susceptible to permanent damage due to electrostatic discharge (ESD).

3.4 Detector Repair

Return a defective detector to the factory for repair service.

**THERE ARE NO USER SERVICEABLE PARTS
IN A MODEL SS3 DETECTOR.**

If a Model SS3 Detector must be shipped back to the factory for repair, it **MUST** be packed in static protected material. An RMA (Return Material Authorization) is required for all returns to the factory. Contact Customer Service for an RMA number before shipping a unit back to the factory.



SS3-A, SS3-AN, SS3-AB, SS3-ABN Electro-Optical Fire Detectors Installation and Operations Guide

SECTION 4 DETECTOR DATA

Table 1: Model SS3 Detector Connectors - Pinouts

DETECTOR INPUT POWER

PIN

- 1 DC Return or Ground (-)
- 2 FireBus Communication (-)
- 3 FireBus Communication (+)
- 4 Power (+24 Volts DC)

FIRE RELAY

PIN

- 5 Fire Relay EOL Resistor (10K ohms)
- 6 Fire Relay Normally Closed
- 7 Fire Relay Common
- 8 Fire Relay Normally Open

Mechanical Layouts

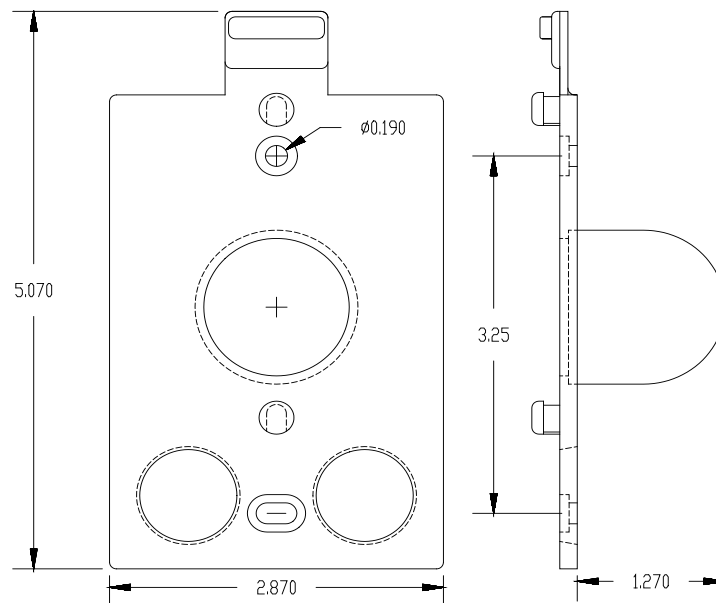
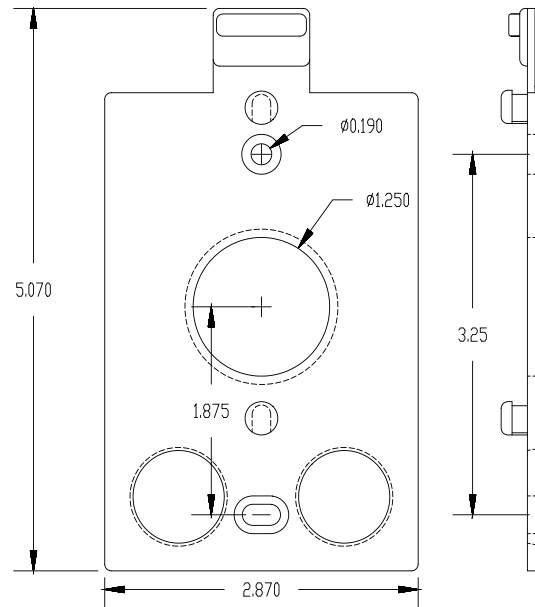

P.N. 188424 for SS3-A and SS3-AN
(Included with Detector)

P.N. 188424(B) for SS3-AB and SS3-ABN
(Included with Detector)

Figure 3
Model SS3 Detector Mounting Brackets

SS3-A, SS3-AN, SS3-AB, SS3-ABN Electro-Optical Fire Detectors Installation and Operations Guide

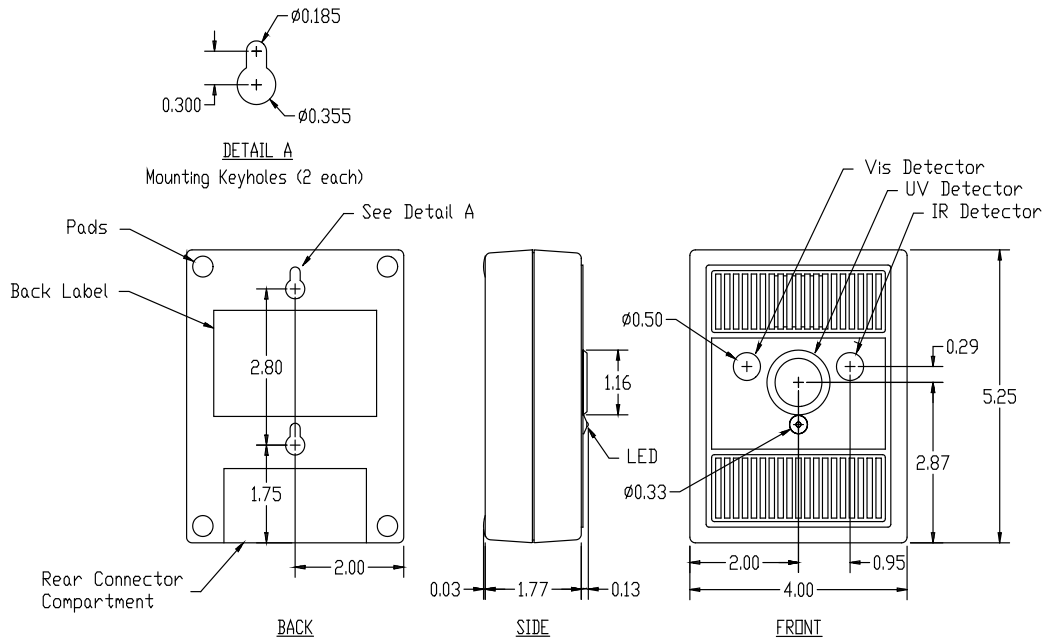

Figure 4
Model SS3-A and SS3-AN Detectors

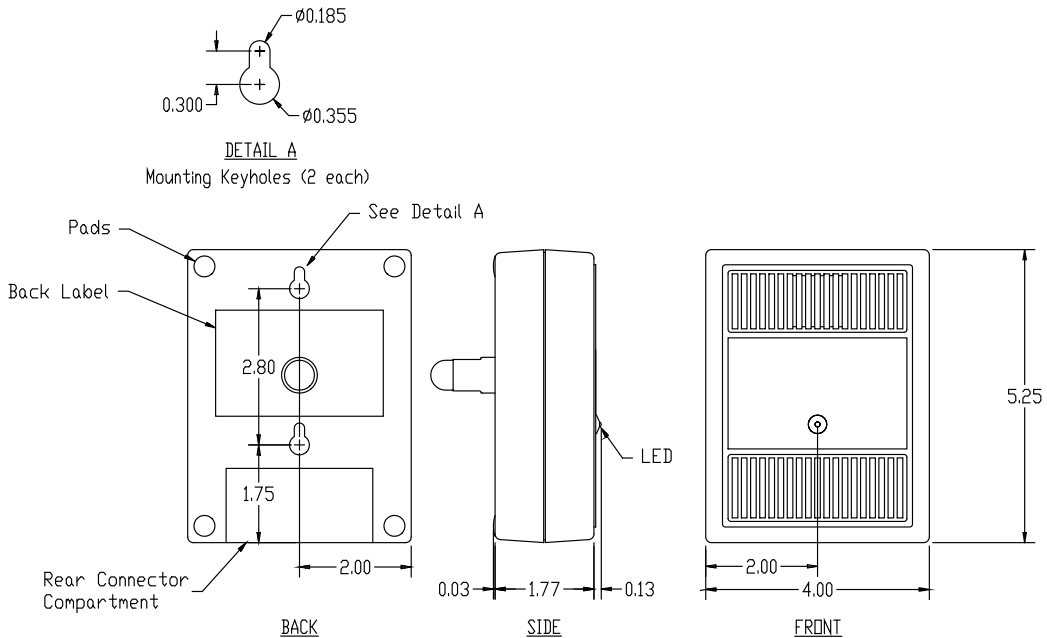

Figure 5
Model SS3-AB and SS3-ABN Detectors

INDEX

C	F	L	S
Cleaning Products , 5	False Alarms, 1	Layout Planning, 2	SS3 See Detector , 1
D	FireBus, 1	M	Stand-Alone, 1
Detector	FireBus	Maintenance , 5	T
Cleaning, 5	Wiring, 2	Mounting Brackets, 7	Test Source, 1
Enclosure, 2	FireLogic, 1	P	Theory of Operation, 1
FireBus, 3	Flame Detector See	Personnel - Qualified, 5	Troubleshooting , 5
LED, 1	Detector, 1	R	
Maintenance	I	Relay	W
Schedule, 5	Installation, 2	Fire, 3, 6	Wiring
Mounting Brackets, 7	Detector, 3		Detector , 4
Pinout, 6	Enclosure, 2		
Replacement, 5	Precautions, 2		
SS3-, 8	J		
SS3-CRUV(B), 9	Junction Box, 2		
Standalone, 3			
Status, 1			
Wiring, 3, 4, 6			



Thank you for reading this data sheet.

For pricing or for further information, please contact us at our UK Office, using the details below.



UK Office

Keison Products,

P.O. Box 2124, Chelmsford, Essex, CM1 3UP, England.

Tel: +44 (0)330 088 0560

Fax: +44 (0)1245 808399

Email: sales@keison.co.uk

Please note - Product designs and specifications are subject to change without notice. The user is responsible for determining the suitability of this product.