



**Searchpoint Optima Plus
Infrared Point Gas Detector**

TOTAL ENVIRONMENTAL SOLUTIONS

Ensure that you read and understand these Operating Instructions BEFORE installing or operating any part of the Searchpoint Optima Plus.

Please pay particular attention to the Safety Warnings.



WARNINGS

1. For installations in the UK, the Code of Practice SELECTION, INSTALLATION AND MAINTENANCE OF ELECTRICAL APPARATUS FOR USE IN POTENTIALLY EXPLOSIVE ATMOSPHERES should be strictly observed. General recommendations are given in BS5345: Part 1: 1989. Specific requirements for flameproof (Type 'd'), intrinsically safe (Type 'i') and increased safety (Type 'e') protection are given in BS 5345: Part 3: 1979, BS 5345: Part 4: 1977 and BS5345: Part 6: 1978 respectively.

For installations in North America, the National Electrical Code (NFPA 70 - 1990) or later issues should be strictly observed.

Elsewhere the appropriate local or national regulations should be used.

2. The Code of Practice regarding SELECTION, INSTALLATION, USE AND MAINTENANCE OF APPARATUS FOR THE DETECTION AND MEASUREMENT OF COMBUSTIBLE GASES (OTHER THAN FOR MINING APPLICATIONS OR EXPLOSIVES PROCESSING AND MANUFACTURE) must be complied with. Refer to BS6959:1988 in the UK or the appropriate local or national regulations.
3. Operators must be fully aware of the action to be taken if the gas concentration exceeds an alarm level.

TOTAL ENVIRONMENTAL SOLUTIONS



CAUTIONS

1. Use only approved parts and accessories with the Searchpoint Optima equipment.
2. To maintain safety standards, a planned maintenance programme is strongly recommended. This maintenance programme should take account of all operational conditions and requirements. Maintenance and service operations should only be performed by personnel qualified to work upon Searchpoint Optima Plus.
3. In order to maintain electrical safety, the unit must not be operated in atmospheres with more than 21% oxygen.

IMPORTANT NOTICES

1. Honeywell Analytics Limited can take no responsibility for installation and/or use of its equipment if this is not done in accordance with the appropriate issue and/or amendment of the manual.
2. The user of this manual should ensure that it is appropriate in all details to the exact equipment to be installed and/or operated. If in doubt, the user should contact Honeywell Analytics Limited for advice.
3. If further details are required which do not appear in this manual, contact Honeywell Analytics Limited or one of their agents.
4. The Searchpoint Optima System is certified for and intended for use in potentially hazardous areas. Install and use the Searchpoint Optima System in accordance with the latest regulations.

Honeywell Analytics Limited reserve the right to change or revise the information supplied in this document without notice and without obligation to notify any person or organisation of such revision or change.

HELP US TO HELP YOU

Every effort has been made to ensure the accuracy in the contents of our documents, however, Honeywell Analytics Limited can assume no responsibility for any errors or omissions in our documents or their consequences.

Honeywell Analytics Limited would greatly appreciate being informed of any errors or omissions that may be found in the contents of any of our documents and to this end we include the form opposite for you to photocopy, complete and return to us so that we may take the appropriate action.

CONTENTS

Section	Page
1. INTRODUCTION	10
1.1 General	10
2. INSTALLATION VARIATIONS	14
2.1 ATEX Units	14
2.2 UL and CSA Units Only	15
3. INSTALLATION	17
3.1 Unpacking	17
3.2 Siting and Orientation	17
3.3 Installation Guide	18
3.4 Attachments and Options	22
3.4.1 General	22
3.4.2 Standard Weather Protection	22
3.4.3 Sunshade/Deluge Protection	22
3.4.4 Storm Baffle	23
3.4.5 Dust Barrier	23
3.4.6 Calibration Cap	24
3.4.7 Gassing Cover	24
3.4.8 Flow Housing	25
3.4.9 Remote Gassing Cell	26
3.4.10 Junction Box Adaptor Plate	27
3.4.11 European Duct Mounting Kit	28
3.4.12 US Duct Mounting Kit	31

CONTENTS

Section	Page
4. ELECTRICAL CONNECTIONS	35
4.1 General	35
4.2 Analogue Connection	40
4.3 Digital Connection	40
4.4 +24V Power Connection	41
4.5 Earth Connection	41
5. COMMISSIONING	46
5.1 General	46
5.2 Commissioning Procedure using SHC-1 and Multimeter	47
5.2.1 Electrical Commissioning and Tests	47
5.2.2 Gas Response Testing	48
5.2.3 System Level Testing	49
5.2.4 Final Commissioning	51
5.3 Commissioning Procedure with Multimeter Only	52
5.3.1 Electrical Commissioning and Tests (Multimeter) Only	52
5.3.2 Gas Response Testing (Multimeter) Only	54
5.3.3 System Level Testing	55
5.3.4 Final Commissioning (Multimeter)	56
5.4 Control System Setup	57
5.5 Functional Response Checking and Calibration	57

CONTENTS

Section	Page
6. CALIBRATION	59
6.1 General	59
6.2 SHC-1 Hand-Held Interrogator	60
6.2.1 Connecting the Hand-Held Interrogator	61
6.2.2 Hand-Held Interrogator Operating Modes	62
6.2.3 Other Hand-Held Features	66
6.3 Calibrating the Controller	70
6.4 Calibrating the Sensor	73
7. ROUTINE CHECKS	81
7.1 General	81
7.2 Inspection and Functional Response Check Procedure	81
7.2.1 Response Check Using Gassing Cover and %LEL Concentration Gas	83
7.2.2 Response Check Using Remote Gassing Cell & High %VV Gas	87
7.3 Inspection and Testing of Units Installed in Ducts	92
7.4 Removal and Refitting of Flow Housing	94
7.4.1 Removal of Flow Housing	94
7.4.2 Refitting of Flow Housing	94

CONTENTS

Section	Page
8. FAULT FINDING	97
8.1 Troubleshooting	97
8.2 Diagnosis of Warning and Fault Messages	103
9. REPLACEMENT OF HAND-HELD INTERROGATOR BATTERY	111
10. ORDERING DETAILS	113
11. SPECIFICATION	117
11.1 Searchpoint Optima Plus Specification	117
11.2 Cross Interference to Other Gases and Vapours	124
11.3 Hand-Held Interrogator SHC-1 Specification	125
11.4 SHC Protection Device	126
11.5 Termination Unit DVC100 Specification	127
11.6 DX Termination Units Specification	128
12. CERTIFICATION DETAILS	130
13. WARRANTY	137

1. INTRODUCTION

1.1 GENERAL

Searchpoint Optima Plus is designed for use in potentially hazardous areas where it provides gas and vapour detection which is free from poisoning and independent of the presence of oxygen. The gas measuring parts of Searchpoint Optima Plus are illustrated below.

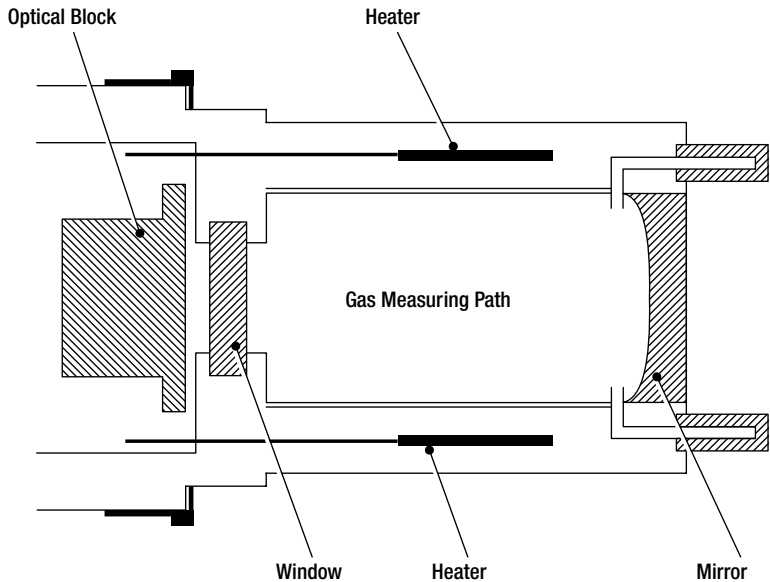

Searchpoint Optima Plus uses the dual wavelength infrared absorption principle to detect hydrocarbon gases and vapours in various concentration ranges. The instrument measures the number of molecules of the target gas in the light path, which depends on the concentration of the target gas. In addition to the relatively long and open measuring chamber, Searchpoint Optima Plus can be fitted with a short enclosed flow through-cell as part of the chassis. This is fitted with separate inlet and outlet ports and allows the application of high concentrations of gas for test purposes.

1. INTRODUCTION

Searchpoint Optima Plus is a micro-processor controlled, Infrared Gas Detector with comprehensive built-in self-diagnostic and fault finding facilities. An analogue 4 to 20mA output and digital communications are provided as standard. Full two way communication allows calibration and advanced self checking procedures to be used. To take advantage of these features a Hand-Held Interrogator unit may be connected to a Termination Unit or via the SHC Protection Device to other junction boxes.

There are several different types of termination unit available:

Termination Unit	Certification	Output
DVC Type Termination Units		
DVC100 (I) MK2	ATEX	Isolated 4-20mA
DVC100 (M) MK2	ATEX	Isolated 4-20mA and MODBUS
DX Type Termination Units		
DVC100 (I)	UL	Isolated 4-20mA
DX100 (M)	UL	Isolated 4-20mA and MODBUS

Searchpoint Optima Plus contains no moving parts and is available in a robust Stainless Steel explosion proof enclosure which has a M25 (ATEX) or 3/4 NPT (UL and CSA) mounting thread. The unit operates over a wide temperature range and has a high degree of protection against dust and water ingress. It is designed to operate in the most arduous conditions and is supplied with a choice of weather protection assemblies.

Searchpoint Optima Plus can be In-Duct Mounted, used in Sampling Systems, is easily confidence checked and may easily replace an existing sensor. Provided that existing cabling has three appropriately rated cores and the installation is correctly screened and earthed, it should not be necessary to replace the field cables or junction boxes. (A current to bridge converter may be required if the controller cannot be configured to accept 4-20mA signals).

1. INTRODUCTION

No special tools are required for installation. Correct function of the detector as installed can be easily confirmed using a Hand-Held Interrogator. Maintenance amounts to occasional cleaning, zeroing and response checking for confidence.

2. INSTALLATION VARIATIONS

2.1 ATEX UNITS

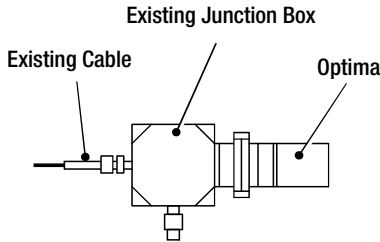

Replacing existing Sensor using existing Junction Box and Cable (where suitable).

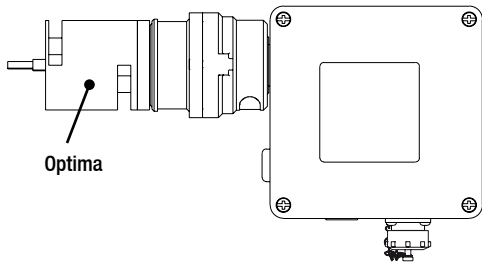

New Junction Box.
New Installations.

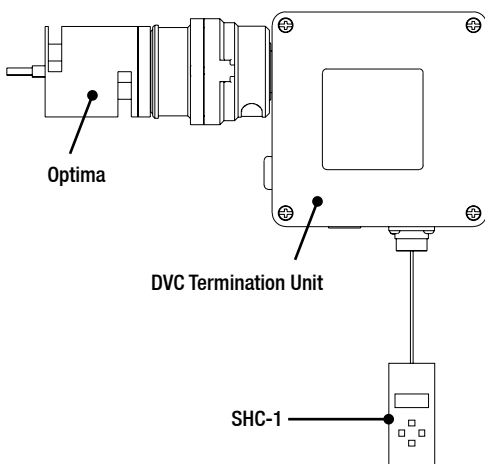

When used for calibration and diagnostics purposes the Hand-Held Interrogator SHC-1 allows digital communication with the Optima. It is connected to the Optima via the IS Socket on the Termination Unit DVC100 or via the SHC Protection Device for other junction boxes.

2. INSTALLATION VARIATIONS

2.2 UL AND CSA UNITS ONLY

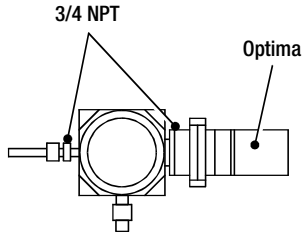

UL and CSA Installations using
Explosion Proof
Junction Box.

Note: The Junction Box must be suitable for the hazardous location in which the Optima is installed, check with the Junction Box manufacturers literature as to suitability of the box.

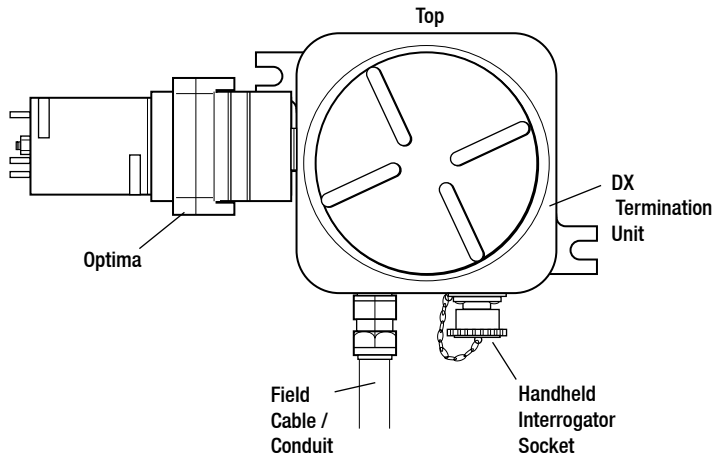

3. INSTALLATION



WARNING

The Code of Practice regarding selection, installation and maintenance of electrical apparatus for use in potentially explosive atmospheres must be complied with at all times.

- Notes:*
- 1. The flying leads of the Searchpoint Optima Plus must be mechanically protected and terminated within a suitable terminal or junction facility.*
 - 2. When the detector is terminated in a hazardous area a suitable UL listed enclosure must be used (where appropriate).*

3.1 UNPACKING

Carefully unpack the equipment, observing any instructions that may be printed on or contained in the packaging, and check the contents for transit damage.

3.2 SITING AND ORIENTATION

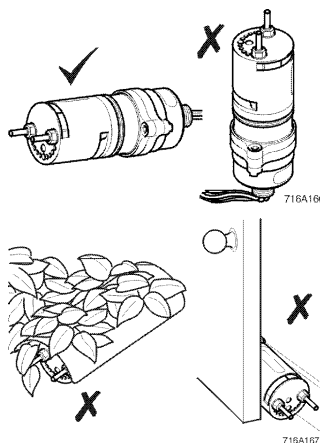

Searchpoint Optima Plus must be mounted horizontally, as this greatly reduces the risk of obscuration due to build up of dirt and moisture on the optical surfaces.

Ensure the area immediately surrounding the sensor is free from objects that could hinder the free flow of air around it.

3. INSTALLATION

For monitoring lighter than air gases, Searchpoint Optima Plus should be mounted above the area requiring protection. For monitoring heavier than air gases it should be mounted below the area to be protected.

When monitoring for heavier than air gases and mounting the detector close to the floor, give consideration to the potential of general site debris to build up on the detector.

Whether Searchpoint Optima Plus is installed in a sheltered or an exposed location, it will require some form of protection around the optics. The standard weather protection combined with the sunshade/deluge protection provides a high degree of protection of the detector, suitable for many outdoor environments. Detectors operating in very exposed locations where torrential rain or driven sea-spray is routinely encountered can benefit from the additional protection provided by the Storm Baffle (2108D0280).

In areas where a high pressure jet may be used at close range to wash down the surrounding location, it is advisable to fit some means of extra peripheral shielding, eg. Storm Baffle or a shield plate.

Accessories and attachments that can be used to improve ease-of-use, performance and reliability in particular installations are described in Section 3.4.

3.3 INSTALLATION GUIDE

Note: Installation of Searchpoint Optima Plus does not require the unit to be opened. There are no user serviceable parts inside the unit. Do not attempt to open or dismantle the unit.

- (1) Ensure that the correct attachments and accessories for the application have been fitted (see Section 3.4).

3. INSTALLATION

- (2) Check that the unit's 4-20mA current output is of the correct type for the control card that it is connected to. (Output type is on a label attached to white lead.)

Control card I/P: SINK Optima O/P: SOURCE
Control card I/P: SOURCE Optima O/P: SINK

- (3) Secure the junction box onto the mounting surface, using the Junction Box Adaptor Plate if required. Searchpoint Optima Plus must be installed with it's long axis horizontal in order for the standard weather protection to operate correctly and to prevent water from settling on the optical surfaces (see below). The Optima unit should therefore only be screwed into a threaded entry that is in a vertical wall of the junction box.

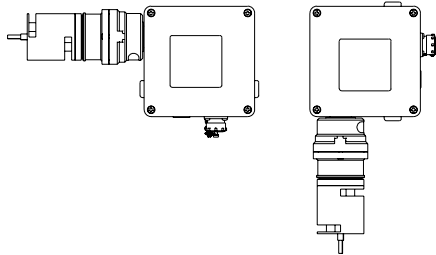

- (4) Feed the unit's wires carefully through the chosen junction box entry and offer up it's threaded boss to the entry. Screw the unit into the junction box until it is secure and the semi-circular pattern of holes on the front of the weather protection are on the bottom (see below). For M25 entries, the boss should go right through the wall and a locking nut should be fitted; whilst for 3/4 NPT entries, the boss should lock off on the taper. If getting the holes in the right orientation requires more rotation than is readily achievable, remove the weather protection and rotate it through 180 degrees.

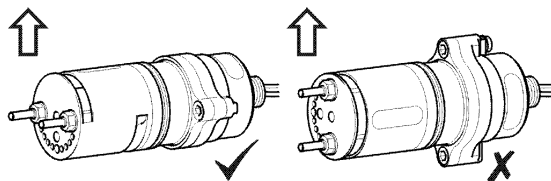

3. INSTALLATION

- (5) Using a multimeter, check that the voltages on the +24V, and 4-20mA connections with respect to 0V are less than +32V DC and that there is no 110V or 230V AC around.
- (6) Wire up the unit's electrical connections in accordance with Section 4, taking note of the general recommendations upon electrical installation.
- (7) Ensure that all cable entries are either used or plugged in strict accordance with the relevant certification requirements and local codes of practice.
- (8) Verify the correct installation and operation of the unit using the SHC-1 handheld interrogator. If a Termination Unit has been used, testing can be performed without the need for a hot work permit. Alternatively, if a basic junction box has been used, electrical connections can be made to the terminals inside the box using the SHC adaptor. This will ordinarily require a hot work permit.



CAUTION

1. Searchpoint Optima Plus is certified and specified for operation in ambient temperatures from -40°C to $+65^{\circ}\text{C}$. Operation of the unit outside of this temperature range invalidates the certification and the warranty. The unit records a non-erasable fault log entry if it is operated at temperatures outside of its certified range.

If the ambient temperature that the unit could be exposed to is likely to go outside of the certified range it is recommended that the unit be located elsewhere. The use of sampling systems can be highly effective, especially in applications where high temperatures are involved.

3. INSTALLATION

2. Searchpoint Optima Plus is specified for operation in environments where the rate of change of unit temperature is less than 3°C / minute. Exceeding this rate of change of temperature will cause the unit to report a fault and may cause permanent damage. If the conditions experienced by the unit are likely to cause it to exceed this rate of change it is recommended that additional preventative measures are taken. The use of sampling systems is highly effective; whilst shielding the unit from the prevailing air flow can also be of benefit.
3. Searchpoint Optima Plus has been vibration tested to the levels specified in EN61779. If the vibration levels on the installation exceed this, the unit's reliability and integrity of operation will be degraded. Do not install units in locations where the vibration exceeds this level.
4. All optical gas detectors are eventually affected by the build up of contaminants / condensation upon their optical surfaces, normally resulting in faults or warnings. In order to minimise the faults and warnings caused by this it is recommended that detectors are located as far away as is possible from sources of airborne contaminants and steam / condensation. Alternatively, the fitting of shields or the Storm Baffle (2108D0280) should be considered. Sources of contamination / condensation that have caused particular problems where appropriate measures were not taken include generator / turbine exhausts, steam lines / vents, drilling operation (oil mist and mud spray) and unfiltered HVAC installations. In dusty atmospheres, regularly check for the build up of dust on the detector (refer to section 7 Routine Checks).

3. INSTALLATION

3.4 ATTACHMENTS AND OPTIONS

3.4.1 General

There are a number of attachments and accessories available for use with Searchpoint Optima Plus. When specifying Optima Plus for a particular application, it is recommended that the user contacts Honeywell Analytics or their representatives to determine the attachments and accessories required. Covers, barriers and baffles provide protection from a wide variety of environmental conditions. Gassing covers, cells and flow housings provide the means of applying gas to the detector. Mounting plates and remote gassing kits enable the detector to be installed in ducts or in places where obtaining routine access is difficult.

3.4.2 Standard Weather Protection (2108D0276)

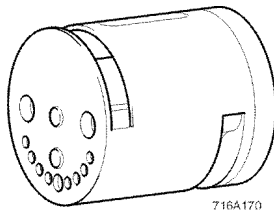

Provides the best compromise between response time and protection. Suitable for indoor, outdoor and duct mounting applications.

3.4.3 Sunshade/Deluge Protection (2108D0275)

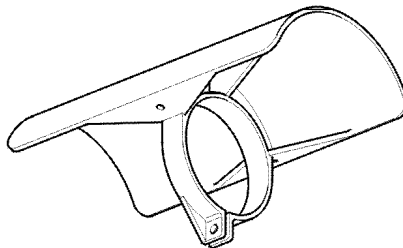

Supplied as standard for all outside applications. Provides additional protection against heavy rainfall, wash downs and direct sunlight.

3. INSTALLATION

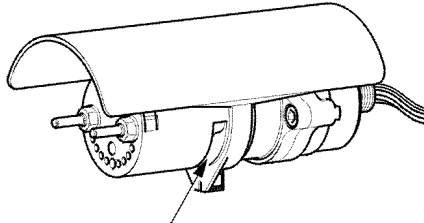

NOTE: DO NOT COVER

716A172

The Sunshade/
Deluge protection
should be clamped
around the base of
the Standard Baffle
Weather Housing with
the longer overhang
extending beyond
the Standard Baffle.
Ensure the clamp
does not cover the
gas venting slot of the
Standard Baffle.

3.4.4 Storm Baffle (2108D0280, Not Illustrated)

The storm baffle provides increased protection against a variety of environmental conditions and effects. It is particularly effective against torrential rain and driven sea-spray and is recommended for exposed installations in maritime locations or areas where monsoon or tropical rain conditions are experienced. The storm baffle can be beneficial in installations where steam drifting over the detector from nearby plant is a problem. The storm baffle can also be useful in some duct applications where the inlets are not filtered and where high flow rates result in dirt build-up or excessive cooling / condensation effects. This accessory will reduce the detector's speed of response.

3.4.5 Dust Barrier (2108D0259, Not Illustrated)

Fits under the standard baffle weather housing to prevent the ingress of dust or oil mist which could contaminate the optical surfaces. It also protects the optics in very wet or exposed locations. This accessory will reduce the detector's speed of response.

3. INSTALLATION

3.4.6 Calibration Cap (2108D0272)

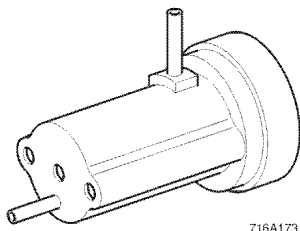

Used to achieve accurate calibration of Optima Plus on the bench. Requires all protective covers and attachments to be removed from the measurement chamber except for the dust barrier. The calibration procedures are described in Section 6.

CAUTION

The Calibration Cap is designed for temporary use on Optima whilst performing calibration. If the calibration cap is left fitted it will prevent ambient gas from reaching the detector's measurement chamber. Ensure that operators are aware that calibration caps must not be left fitted. In order to reduce the likelihood of this mistake going un-noticed, the calibration caps are coloured red.

3.4.7 Gassing Cover (2108D0258)

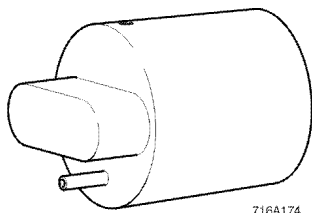

Provides a convenient means of applying gas to Optima Plus units in the field. Suitable for functional test and calibration purposes. Fits over the standard weather protection, covering the gas inlet slots. Gas is introduced into the weather protection via an injection tube on the gassing cover. Injected gas diffuses through the dust barrier into the measurement chamber. The response check procedure is described in Section 5.4.

3. INSTALLATION

CAUTION

The Gassing Cover is designed for field testing and calibration operations. If the cover is left fitted it will prevent ambient gas from reaching the detector's measurement chamber. Ensure that operators are aware that gassing covers must not be left on detectors. Gassing covers are coloured red to reduce the likelihood of this mistake.

3.4.8 Flow Housing (2108D0282)

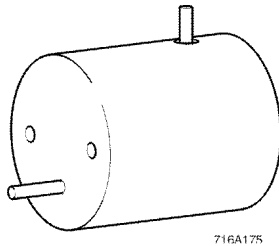

For use in sampling system applications.

The Flow Housing is fabricated from solvent resistant Anodised Aluminium.

The nozzles on the Flow Housing are stainless steel with an outside diameter of 6mm.

It is advised that sample gases and vapours are sucked (negative pressure) rather than blown (positive pressure) through this housing and that sample flow rates do not exceed 2 litres per minute.

It is recommended that a flow failure indicator is fitted within the sampling system and the minimum flow rates are suitable for the application and not less than 0.7 litres per minute.

Note: response time will increase with a decreasing flow rate.

The commissioning and calibration of an Optima equipped with a flow housing is described in Sections 5 and 6.

3. INSTALLATION

3.4.9 Remote Gassing Cell (2108B0240)

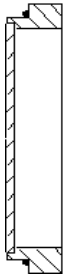

The Remote Gassing Cell (RGC) enables high %V/V concentration gas to be applied remotely for performing functional response checks (bump tests). It is useful for units installed in ducts or in areas where obtaining access is difficult. The RGC window can be removed for cleaning.

Note:

During production, Optima Plus units are calibrated with gas in the main measurement chamber, not in the RGC. The RGC is not recommended for calibration or high accuracy calibration testing purposes.

(The only exception to this is where units are being used to measure high %V/V gases using the RGC as a flow cell. In this instance, the units are production calibrated with gas in the RGC.)

In order to avoid pressurisation effects, the flow rate should be kept below 0.3 litres / minute.

The RGC option is factory fitted.

3. INSTALLATION

3.4.10 Junction Box Adaptor Plate (04200-A-1040)

The Junction Box Adaptor Plate provides a means of increasing the spacing between the junction box's gland entries and the mounting surface. This enables low gland clearance junction boxes to be used without the Optima Plus fouling on the wall / mounting surface. Junction boxes which can be accommodated include the Hawke PL612 and PJB1.

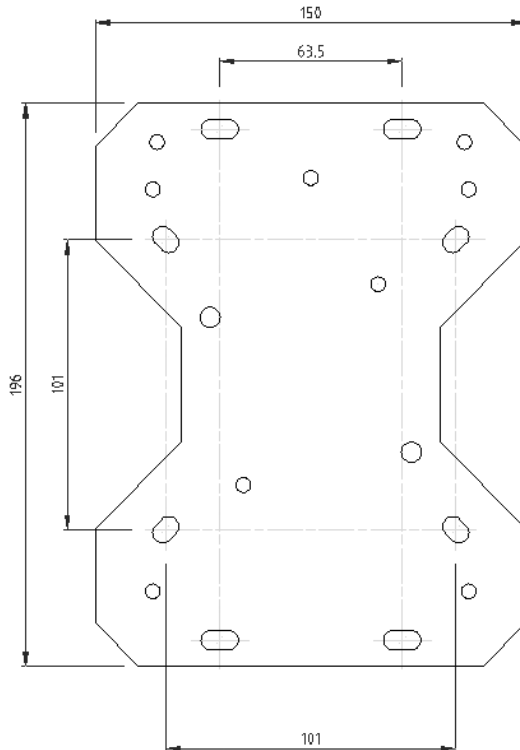

3. INSTALLATION

3.4.11 European Duct Mounting Kit (04200-A-1015)

This kit enables Optima Plus to be conveniently mounted inside a duct. Electrical connections are made to the detector via a junction box which is mounted outside of the duct. Using this kit, test gas can be non-invasively applied to the detector via the gassing points provided.

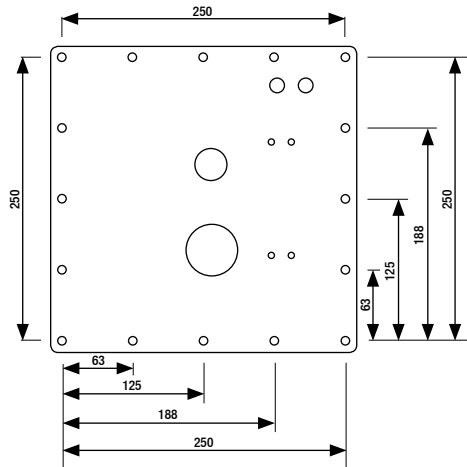

Note 1: Dimensions shown in mm.

Note 2: The cutout in the duct should be 230mm x 230mm.

3. INSTALLATION

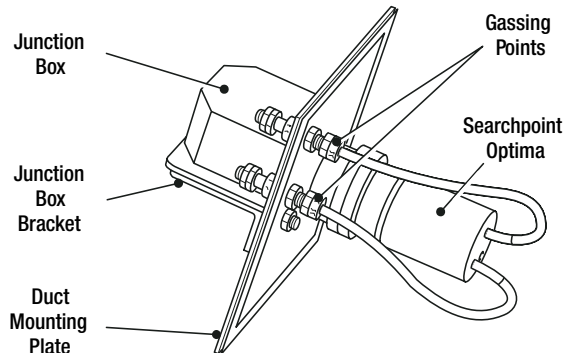

Notes: 1. In order to make use of the gassing points provided, the Optima unit must be fitted with the Remote Gassing Cell (2108B0240).

2. In offshore HVAC ducts or ducts without inlet filtering, the use of the Storm Baffle (2108D0280) is recommended.

3. CSA approval only applies for flow rates less than 5 m/s and does not cover the use of the Storm Baffle.

The duct mounting kit is assembled and installed onto a duct as below:-

(1) Cut a square 230mm * 230mm hole in the duct wall. Drill the holes required to attach the mounting plate to the duct wall.

(2) Place the Optima unit on the side of the mounting plate where the threaded bushes protrude and feed the wires through the central hole.

3. INSTALLATION

- (3) Locate the unit's boss in the central hole and feed the unit's wires through the chosen cable entry on the junction box.
- (4) Screw the unit into the junction box until the assembly is secure with the mounting plate trapped between the box and the Optima.
- (5) Cut off the seals on the ends of the gassing cell inlet tubes.
- (6) Attach the gassing tubing to the ends of the gassing cell inlet tubes.
- (7) Fasten the mounting plate to the wall of the duct, ensuring that the seal is compressed.
- (8) Wire up the unit in accordance with the electrical connection details in Section 4.
- (9) Ensure that all cable entries are either used or plugged in strict accordance with the relevant certification requirements and local codes of practice.

3. INSTALLATION

3.4.12 US Duct Mounting Kit

This kit enables Optima Plus to be conveniently mounted inside a duct. Electrical connections are made to the detector via a junction box which is mounted outside of the duct. Using this kit, test gas can be non-invasively applied to the detector via the gassing points provided.

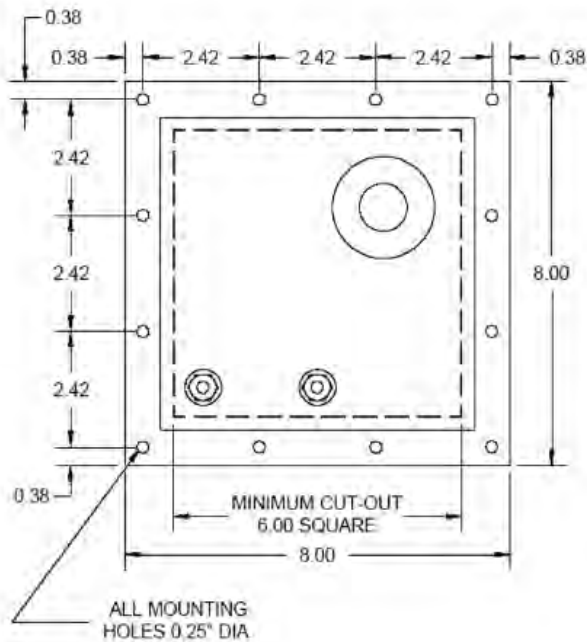

Note 1: Dimensions shown in inches.

3. INSTALLATION

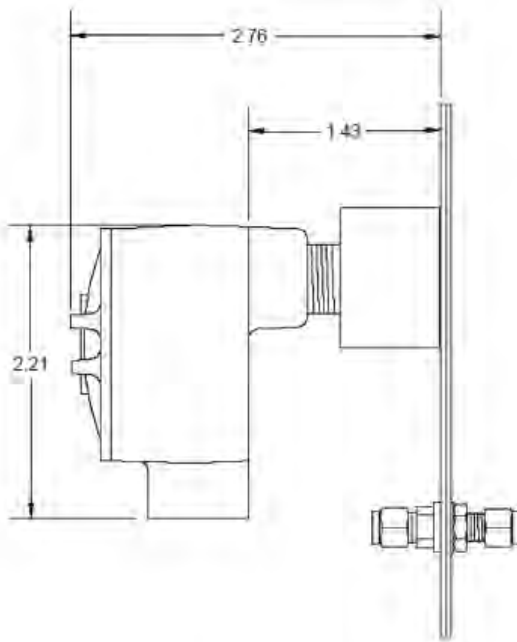

The duct mounting kit is assembled and installed onto a duct as below:-

- (1) Cut a square 6" x 6" hole in the duct wall. Drill the holes required to attach the mounting plate to the duct wall.
- (2) Remove the cover from the junction box.

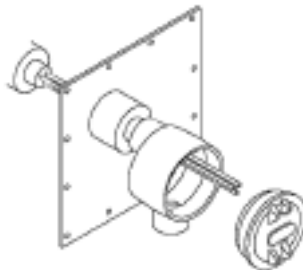

3. INSTALLATION

- (3) Feed the wires from the Searchpoint Optima Plus through the weldment into the junction box. **DO NOT SECURE THE WIRES TO THE TERMINALS AT THIS TIME.**
- (4) Secure the sensor to the weldment.
- (5) Attach the both tubing assemblies.

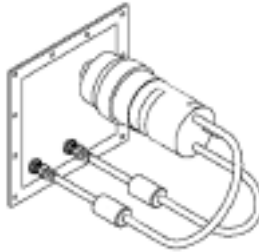

- (6) Secure the mounting plate to the duct.

4. ELECTRICAL CONNECTIONS

CAUTION

The reliability and performance of instrumentation installed at industrial and petrochemical facilities can be strongly influenced by the design and quality of the electrical installation. It is strongly recommended that before designing an electrical installation for Searchpoint Optima Plus the electrical installation design authority reads Section 4.1.

4.1 GENERAL

Searchpoint Optima Plus complies with the European EMC requirements set out in standard EN50270:1999. In order to maintain compliance with these standards it is essential that the electrical installation of Searchpoint Optima Plus is engineered appropriately.

Electrical installation standards and practices vary for different countries, companies and hazardous area approvals. It is the responsibility of the electrical installation design authority to determine the applicable standards / practices and ensure compliance with them. When designing electrical installations for Searchpoint Optima Plus it is recommended that the design authority considers the following:-

- a. Ideally, the cases of units should not be connected to electrically noisy (dirty) metalwork or conductors. Preferably, the case (internally connected to the unit's green / yellow GND wire) should be connected to a low noise instrument (clean) earth.
- b. Preferably, the field cable screen should be connected to the unit's green / yellow GND wire, providing a single, continuous earth screen connected to a low noise instrument (clean) earth. This connection must

4. ELECTRICAL CONNECTIONS

not be allowed to complete an earth loop or connect instrument earth to safety earth.

- c. If armoured cable is being used it is necessary to prevent safety (dirty) earth from becoming connected to instrument (clean) earth via the continuity plate in the field junction box. This is most easily achieved by the use of insulating cable glands for the field cable entry.
- d. For UL / CSA certified installations it is not practical to isolate the unit's case from safety (dirty) earth. The unit and its junction box should be earthed in a manner that complies with the certification requirements.
- e. Any earth / ground bonding arrangement employed should ensure that the maximum peak voltage between the unit's case earth and any field cable conductor is less than 350V. This includes conditions where transient surge voltages are generated by lightning or the switching of heavy electrical plant. Surge voltages in excess of 350V can cause permanent damage to the unit's RFI filters and such damage is not covered by warranty.
- f. Earthing / grounding arrangements that employ multiple protective earths or earth grids significantly increase the likelihood of large transient surge voltages being generated between a unit's case earth and the field cable conductors.
- g. If it is suspected that the earth / ground bonding arrangement employed will not prevent voltages between the unit's case earth and any field cable conductor from exceeding 350V it is strongly recommended that surge suppression devices be installed close to the unit. Suitable, certified surge suppression devices include MTL's TP-48-I-NDI and

4. ELECTRICAL CONNECTIONS

Pepperl & Fuchs' FN-LB-1. Two of these devices are sufficient to provide protection of the +24V, 0V, 4-20mA and RS485 (A) connections to a unit.

- h. In general, correctly engineered star earthing arrangements minimise earth current crosstalk and noise, improving the reliability and performance of instrumentation.
- i. Low noise instrument (clean) earth should only be connected to safety earth (usually dirty) at a single point on a site / installation. This connection should be made in such a manner that it does not introduce noise onto the instrument earth.
- j. The entire length of the field cabling connected to a unit should be screened / shielded. This screen / shield should be connected to a low noise instrument (clean) earth at a single end. (The screen / shield can be connected to the unit's earth in the junction box, provided that this is isolated from all other earths / grounds.)
- k. For installations where the field cable conductors run through conduit or armour connected to safety (dirty) earth, the conduit or armour should not be considered as a sufficient screen / shield. A separate cable screen / shield, connected to a low noise instrument earth should be employed.
- l. The screens / shields of field cabling should not be connected in a manner that creates earth loops or that will result in the screens / shields carrying large currents from heavy plant or equipment.
- m. The use of a single, screened / shielded cable for each field device ensures good screening / shielding and reduces crosstalk. Cabling arrangements that use a single cable to connect a number of field devices

4. ELECTRICAL CONNECTIONS

compromise screening and increase the potential for crosstalk. Such arrangements should only be employed if the electrical installation design authority is confident that this will not adversely affect the reliability or performance of the system.

- n. Any electrical interference induced onto the conductors of a 4-20mA loop by the installation must be kept below the levels necessary to comply with the general requirements of EN61779 or other applicable gas detector performance requirements / standards. In practice, this means that peak noise currents induced on the current loop should be no greater than +/- 0.25mA. If peak noise currents larger than this are induced on the current loop it is possible that spurious gas readings, alarms and faults will be reported by the control system monitoring the current loop.
- o. The 0V rail of a control card / control system is often connected directly to one side of the 4-20mA input's current sensing resistor. In such instances, any electrical noise on the 0V rail can be considered to be directly connected to the 4-20mA input. In order to reduce the likelihood of such noise adversely affecting the performance of a gas detection system it is desirable to keep noise on the 0V rail to a minimum. Safety earth / ground frequently carries a high level of electrical noise and it is therefore advisable not to connect the 0V rail to safety earth / ground. If the 0V rail cannot be isolated from earth it is advisable to either connect it to a low noise instrument (clean) earth or through a path that presents a high impedance to noise on the earth.
- p. For installations in Europe, all electrical equipment connected to the system should comply with EN50270. For non-European installations, electrical equipment connected to the system should comply with applicable national or international EMC standards.

4. ELECTRICAL CONNECTIONS

- q. Searchpoint Optima Plus is designed to operate correctly with supply voltages down to 18V. When supplied with 18V, the maximum current drawn by a single Searchpoint Optima Plus unit will be 250mA. The field cabling conductors should have sufficient cross sectional area to ensure that when a unit is drawing 250mA the voltage reaching it does not fall below 18V. For a control room voltage of 24V, the maximum round loop cable resistance must therefore be 24 Ohms. Round loop cable resistances greater than those necessary to ensure that units always receive at least 18V may result in unreliable operation.

- r. Ideally, the 24V supply reaching units should be free from large transients, fluctuations or high frequency noise. Transients or fluctuations which take the supply voltage outside of the 18-32V range may result in units switching off and re-booting.

- s. In order to reduce the likelihood of radio frequency interference affecting the operation of units it is recommended that neither units nor their cabling are installed in close proximity to the antennae of high powered radio, radar or satellite communication equipment.

4. ELECTRICAL CONNECTIONS

4.2 ANALOGUE CONNECTION

The unit's analogue 4-20mA output is non-isolated and shares the 0V return (black wire) connection with the DC supply to the unit. The 4-20mA output is factory configured for current source or current sink. The configuration is identified by a label on the white 4-20mA output wire. The connections to the unit are shown in the following figures.

Note: If using Searchpoint Optima Plus to replace an existing catalytic sensor, a Current to Bridge converter must be used.

4.3 DIGITAL CONNECTION

Searchpoint Optima Plus has a built-in RS485 digital communications link. When using Termination Units, this link can be connected to using the IS socket. For other junction boxes, this link can be connected to using the SHC Protection Device between the junction box terminals and the SHC-1 Handheld Interrogator.

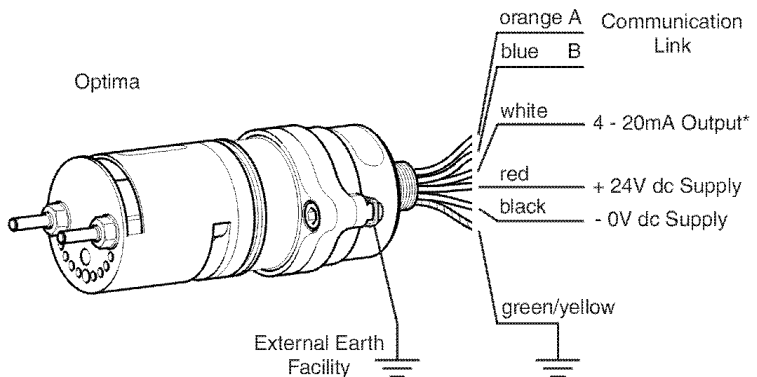

716A176

4. ELECTRICAL CONNECTIONS

The RS485 communications link is connected to the unit's orange (RS485(A)) and blue (RS485(B)) wires. If not used, these wires must be separately terminated in a suitable terminal or junction facility.

4.4 +24V POWER CONNECTION

The +24V DC power supply feed should be connected to the unit via the red (+24V) and black (0V return) wires.

4.5 EARTH CONNECTION

An earth connection can be made to the unit in a number of ways. When deciding how to earth the unit, consideration should be given to the recommendations in section 4.1. Physically, the earth connection can be made either via the unit's green/yellow earth wire, a metal nut between the unit and the junction box's earth continuity plate or a wire connected to the unit's external earthing point.

4. ELECTRICAL CONNECTIONS

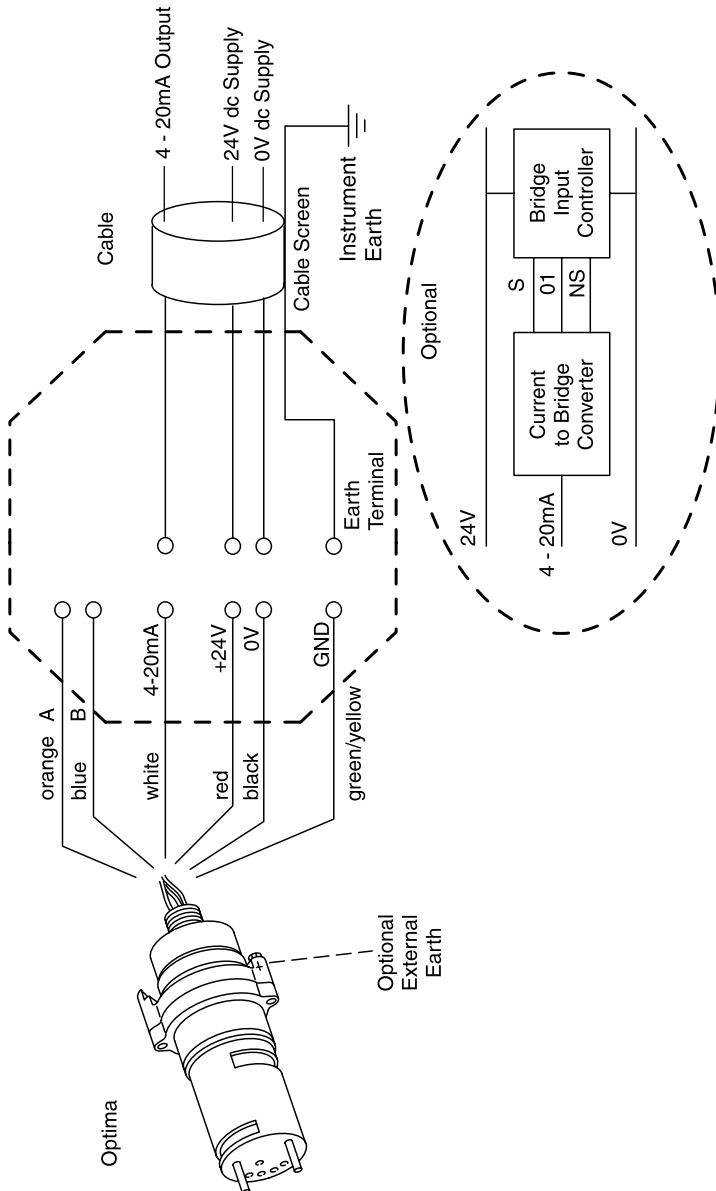

Minimum Configuration for Retrofit Application (Optional Current to Bridge Converter)

4. ELECTRICAL CONNECTIONS

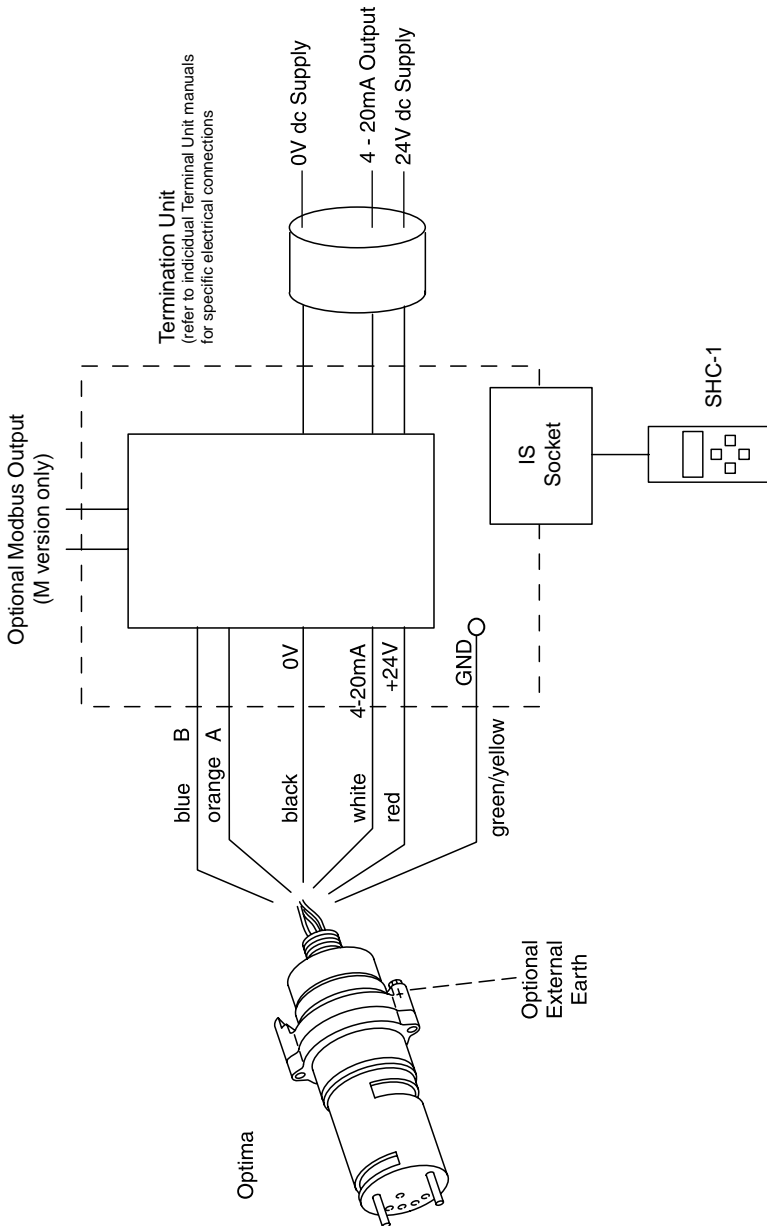

Configuration for Termination Unit with IS Socket and Hand-Held Interrogator

4. ELECTRICAL CONNECTIONS

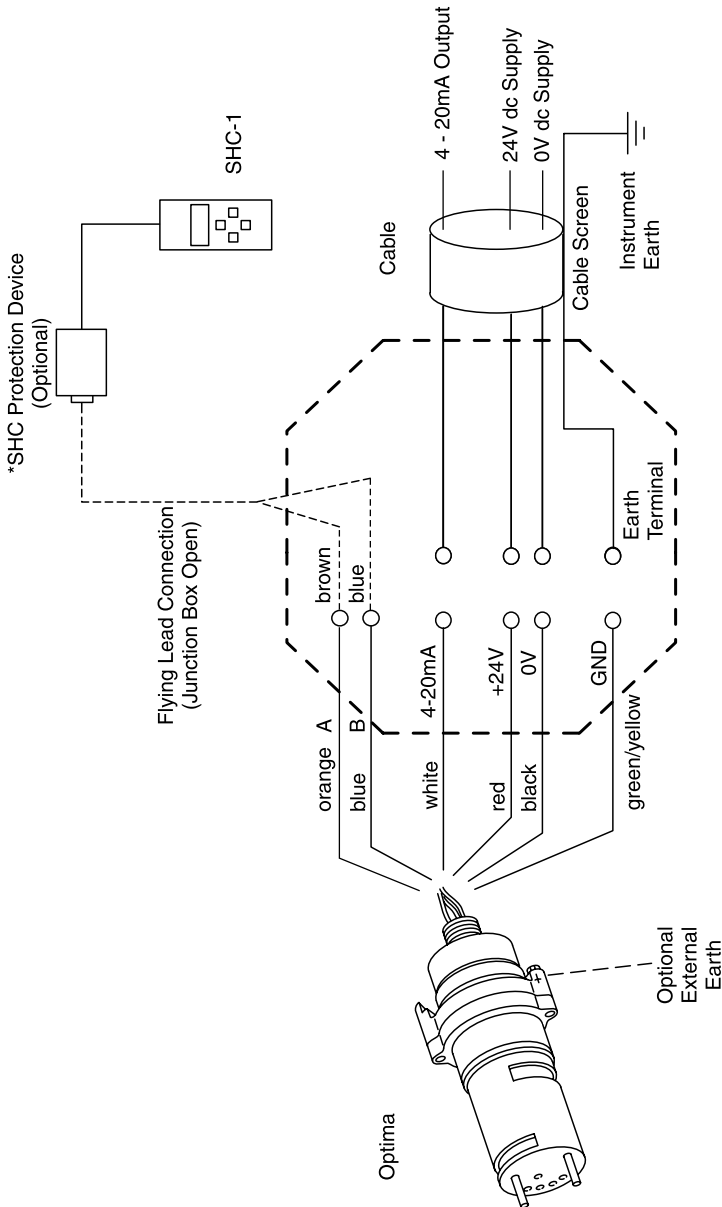

Standard Configuration for Retrofit Application (With SHC Protection Device and Hand-Held Interrogator Option.)

5. COMMISSIONING

5.1 GENERAL



WARNINGS

1. Alarm level signals may be intentionally generated during the commissioning procedure. Ensure that appropriate steps are taken to prevent the unintended sounding of alarms or executive actions. It is recommended that the control card corresponding to the detector is isolated or inhibited during the majority of the commissioning procedure.
2. In order to commission units installed with basic junction boxes (i.e. not DVC100 or DX100), it will be necessary to open the junction boxes under power. This will require the appropriate safe operating procedures to be employed.
3. The Optima Plus commissioning procedure is best performed using an SHC-1 Handheld Interrogator and a digital multimeter. Use of the SHC-1 interrogator in combination with a multimeter enables more comprehensive checks and testing (Section 5.2). If however, an SHC-1 interrogator is not available, basic commissioning can be performed using just a multimeter (Section 5.3).

IMPORTANT

Searchpoint Optima Plus is supplied calibrated and ready for use. It does not require calibration during commissioning. Reference is made in this section to a Gas Response Test. This is not a full calibration of the sensor where zero and span values are set, but a response test using a known concentration of gas to **validate** the calibration of the sensor.

5. COMMISSIONING

5.2 COMMISSIONING PROCEDURE USING SHC-1 AND MULTIMETER

5.2.1 Electrical Commissioning and Tests (SHC-1 & Multimeter)

The procedure for verifying the electrical installation of the unit is described below:-

- (1) Before applying power to the unit, ensure that the field wiring is correct and all electrical connections are in accordance with Section 4.
- (2) Check that the unit's 4-20mA output configuration is correct for the type of control card that it is connected to. (Source output for sink input, sink output for source input. Unit's output configuration is on label attached to white wire.)
- (3) Apply power to the control card connected to the unit being commissioned. Wait for 1 minute to allow the unit to initialise and stabilise. Using a multimeter set on dc volts, measure the voltage across the red (+24V) and black (0V return) connections. Nominally, this voltage should be +24V. Voltages in the range +18V to +32V are acceptable.
- (4) Using either the IS socket on the Termination Unit, or the SHC Protection Device, connect the SHC-1 Handheld Interrogator to the unit's RS485 comms link.(See Section 4.2 for SHC Protection Device connections.)
- (5) Select the DIAGNOSTICS option on the interrogator menu and instruct the unit to display any ACTIVE WARNINGS or ACTIVE FAULTS. (Diagnosis of FAULT / WARNING codes is described in Section 8.)

5. COMMISSIONING

- a. If there are any ACTIVE FAULTS, the cause(s) of these must be identified and remedied before the unit will become fully operational.
- b. If there are any ACTIVE WARNINGS, the unit can operate correctly despite the warning(s). However, for reliable long term operation it is strongly recommended that problems causing warnings are fixed before a unit is fully commissioned.

5.2.2 Gas Response Testing (SHC-1 & Multimeter)

The procedure for testing gas response as part of the commissioning process is described below:-

- (1) Select the DISPLAY mode on the SHC-1 Handheld Interrogator. Check that the displayed gas reading is 0.0% LEL. If the displayed gas reading is not 0.0% LEL, check that there is no background gas concentration present, the optics are clean and free from condensation and that the unit has been given sufficient time to stabilise in its intended operating environment. (For best results, it is recommended that a unit is left powered up for one hour before performing zero or span calibration / test activities.)
- (2) Using the SHC-1 interrogator, put the detector into INHIBIT (this will prevent gas readings from being signalled on the 4-20mA output).
- (3) Making use of either the gassing cover, or the remote gassing cell (where fitted), perform a functional gas test. The procedure for performing functional gas tests is detailed in Section 5.5. For a nominal 50% LEL test gas concentration, the displayed reading should be between 45% LEL and 55% LEL. (If necessary, test gas concentrations between 20%LEL and 95%LEL can be used with the same +/- 5% LEL test tolerance.)

5. COMMISSIONING

Provided the displayed gas reading falls within the +/-5% LEL test tolerance range, the functional gas test has been completed satisfactorily.

CAUTION

If the displayed gas reading is not as expected, do not proceed to re-calibrate the unit immediately. Instead, double check the unit's zero, the test gas and the gassing technique. (IR gas detectors do not exhibit significant span drift and in most instances, any problem will be with the zero or the test gas / technique.) Only consider re-calibrating a unit when certain that the zero, test gas and technique are correct and that the unit's gas response is significantly out. The calibration technique is detailed in Section 6.3.

5.2.3 System Level Testing (SHC-1 & Multimeter)

Confirmation of correct operation of the complete gas detection system can be done using either test gas at the required concentrations (Option B) or by FORCEing the unit's 4-20mA output under control of the SHC-1 interrogator (Option A):-

CAUTION

When performing system level tests, ensure that any resulting alarms or executive actions will not give rise to unintended emergency drills or loss of production / shut-down.

Note: It is assumed that the control system has been set up for currents of 4mA and 20mA to read 0.0% LEL and 100% LEL respectively. If necessary, the FORCE 4-20mA option can be used for setting up the control card. Be aware that a 10 minute timeout applies to FORCE'd 4-20mA outputs.

5. COMMISSIONING

Option A) System Test Using FORCE'd 4-20mA

- (1) The easiest way of performing system level functional tests is to use the SHC-1 interrogator to FORCE the 4-20mA output to currents that are just above the relevant alarm thresholds.
- (2) The FORCE 4-20mA option is available from the CALIBRATE menu. Using this option, FORCE the 4-20mA output to a current just above the A1 alarm threshold. For example, with an A1 of 20% LEL, a current of 7.5mA should suffice. Verify that the system reports and responds as intended to this A1 signal.
- (3) FORCE the 4-20mA output to a current just above the A2 alarm threshold. With an A2 of 60% LEL, a current of 14mA should suffice. Verify that the system reports and responds correctly to this A2 signal.
- (4) RELEASE the 4-20mA output. Confirm that the system returns to normal, with no active alarms or faults.

Option B) System Test Using Gas

If system level functional tests must be performed using gas, test gas concentrations at least 5% LEL (ideally 10% LEL) above each alarm threshold are required in order to allow for system tolerances.

- (1) Using either the gassing cover or the remote gassing cell, apply test gas to the detector at the concentration required to reliably exceed the A1 alarm threshold. For example, with an A1 alarm threshold of 20% LEL, the minimum nominal test gas concentration should be 25% LEL (ideally 30% LEL). Verify that the system responds as intended to an A1 signal generated in this manner.

5. COMMISSIONING

- (2) Apply test gas at the concentration required to reliably exceed the A2 alarm threshold. With an A2 alarm threshold of 60% LEL, the minimum nominal test gas concentration should be 65% LEL (ideally 70%LEL). Verify that the system responds correctly to an A2 signal generated in this manner.

5.2.4 Final Commissioning (SHC-1 & Multimeter)

The commissioning process is finished off as described below:-

- (1) Remove or disconnect any gas testing equipment from the unit.
- (2) Ensure that any test gas used is fully vented from the measurement chamber or gassing cell. Verify that the displayed gas reading returns to zero. (If the remote gassing cell has been used, ensure that once vented, it's inlet tubes are sealed with the protective caps provided (or a suitable alternative).)
- (3) If required, remove the detector from INHIBIT.
- (4) Select DIAGNOSTIC mode and verify that the unit has no ACTIVE FAULTs or ACTIVE WARNINGS.
- (5) Disconnect the SHC-1 interrogator. Replace the junction box lid (where removed).
- (6) When all of the relevant steps above are completed satisfactorily, the unit has been commissioned and is ready for operational use.

5. COMMISSIONING

5.3 COMMISSIONING PROCEDURE WITH MULTIMETER ONLY

5.3.1 Electrical Commissioning and Tests (Multimeter) Only

The procedure for verifying the electrical installation of the unit is described below:-

- (1) Before applying power to the unit, ensure that the field wiring is correct and in accordance with Section 4.
- (2) Check that the unit's 4-20mA output configuration is correct for the type of control card that the unit is connected to. (Source output for sink input, sink output for source input. The unit's output configuration is on a label attached to the white wire.)
- (3) Apply power to the control card connected to the unit being commissioned. Wait for 1 minute to allow the unit to initialise and stabilise. Using the multimeter set on dc volts, measure the voltage across the red (+24V) and black (0V return) connections. Nominally, this voltage should be +24V. Voltages in the range +18V to +32V are acceptable.
- (4) Remove power from the unit.
- (5) Insert the multimeter set to read current (mA) in series with the 4-20mA loop as follows:-

- a. Current Sink Output

Remove the unit's white 4-20mA output wire from the terminal for the 4-20mA loop connection. Connect the multimeter's negative probe to the white 4-20mA wire. Connect the multimeter's positive probe to either the +24V terminal or the 4-20mA loop terminal.

5. COMMISSIONING

b. Current Source Output

Remove the unit's white 4-20mA output wire from the terminal for the 4-20mA loop connection. Connect the multimeter's positive probe to the white 4-20mA wire. Connect the multimeter's negative probe to either the 0V terminal or the 4-20mA loop terminal.

- (6) Apply power to the unit and monitor its 4-20mA output to confirm that it executes the correct power-up sequence as below:-
- a. Output current of 0.0mA (0.0 to 0.5mA) for a period of approximately seven seconds.
 - b. Output current of 2mA (INHIBIT current, 1.8 to 2.2mA) for a period of up to one minute whilst the unit initialises and stabilises.
 - c. Output current of 4mA (ACTIVE zero gas current, 3.8mA to 4.2mA), which indicates that the unit is operational and reading 0.0% LEL gas.

Note: If the unit is powered up in a non-zero gas concentration, it will output a signal corresponding to the gas concentration.

5. COMMISSIONING

5.3.2 Gas Response Testing (Multimeter) Only

CAUTION

Without the SHC-1 interrogator it is not possible to INHIBIT the gas detector. To avoid unintended executive actions or alarms, it is recommended to either isolate the detector itself or inhibit / isolate the corresponding control card.

Functional gas testing can be performed using the multimeter to monitor the 4-20mA output:-

- (1) Isolate the detector by disconnecting the 4-20mA output from the loop terminal and connecting the multimeter to measure the 4-20mA current to either the +24V (for current sink) or 0V (for current source). Alternatively, if the control card has been isolated / inhibited, connect the multimeter in series with the 4-20mA loop.
- (2) Making use of either the gassing cover, or the remote gassing cell (where fitted), perform a functional gas test as detailed in Section 5.5.

CAUTION

If the 4-20mA current is not as expected, double check the unit's zero, the test gas and the gassing technique. (IR gas detectors do not exhibit significant span drift and in most instances the problem is with the zero or the test gas / technique.) Only consider re-calibrating a unit when certain that the zero, test gas and technique are correct and that the unit's gas response is significantly out. The calibration procedure is detailed in Section 6.3.

5. COMMISSIONING

For a nominal 50% LEL test gas concentration, the 4-20mA output current should be between 11mA and 13mA. If the measured current falls within the correct range, the functional gas test has been completed satisfactorily.

Note: Zeroing and calibration activities require use of the SHC-1 interrogator.

5.3.3 System Level Testing (Multimeter)

If it is necessary to confirm the correct operation of the complete gas detection system during commissioning (without an SHC-1 interrogator), this can only be done using test gases at concentrations which are at least 5% LEL (ideally 10% LEL) above the relevant alarm thresholds.

- (1) Remove power from the unit. Reconnect the unit's 4-20mA output to the appropriate loop terminal (the multimeter should still be in series to measure current).
- (2) Making use of either the gassing cover, or the remote gassing cell (where fitted), introduce gas at the required A1 test concentration into the unit. For example, with an A1 alarm threshold of 20% LEL, the minimum test gas concentration required is 25% LEL. The corresponding 4-20mA output current should be between 7.2mA and 8.8mA. Confirm that the correct current and system responses are observed when the A1 test gas is introduced into the unit.
- (3) Introduce gas at the required A2 test concentration into the unit. With an A2 alarm threshold of 60% LEL, the minimum test gas concentration required is 65% LEL. The corresponding 4-20mA output current should be between 13mA & 15mA. Confirm that the correct current and system responses are observed when the A2 test gas is introduced into the unit.

5. COMMISSIONING

5.3.4 Final Commissioning (Multimeter)

The commissioning process is finished off as described below:-

- (1) Remove or disconnect any gas testing equipment from the unit.
- (2) Ensure that any test gas used is fully vented from the measurement chamber or gassing cell. (If the remote gassing cell has been used, ensure that once vented, it's inlet tubes are sealed with the protective caps provided (or a suitable alternative)).
- (3) Verify that after the initialisation and stabilisation period (approximately 1 minute), the 4-20mA output returns to 4mA nominal (between 3.8mA and 4.2mA).
- (4) Remove power from the unit and disconnect the multimeter from the 4-20mA loop. Connect the white 4-20mA wire back directly to the loop terminal. Re-apply power to the unit.
- (5) Verify that the unit returns to ACTIVE status and that the gas reading displayed on the control card is 0.0% LEL.
- (6) Replace the junction box lid.
- (7) When all of the relevant steps above are completed satisfactorily, the unit has been commissioned and is ready for operational use.

5. COMMISSIONING

5.4 CONTROL SYSTEM SETUP

If the controller is in need of setting up, ie. for a 4 to 20mA signal to show an equivalent reading eg. 0 - 100% fsd, this may be done in two ways:

- i) By using the Hand-Held Interrogator to FORCE the required signal to the controller (see Section 6.4 of this manual)

or

- ii) With calibration gas applied to the sensor.

In each of these cases, a known signal is sent to the controller, and the controller is set to show the equivalent signal.

5.5 FUNCTIONAL RESPONSE CHECKING AND CALIBRATION

Searchpoint Optima Plus is supplied factory calibrated and when commissioning a unit, all that should be required to verify correct operation is a functional response check. The procedure for functional response checking is described in Section 7 Routine Checks.

Where local regulations or working practices require gas detectors to be calibrated when they are commissioned, this should be performed in accordance with the procedure described in Section 6 Calibration.

6. CALIBRATION

6.1 GENERAL

Searchpoint Optima Plus is supplied factory calibrated for a particular hydrocarbon gas (approximately 100 different gas calibrations are currently available). Properly installed and maintained, Optima Plus does not require routine calibration. This operational benefit is made possible by the inherent stability of the IR absorption process and the fully compensated optical configuration used. In order to maintain confidence in the continued correct operation of fielded Optima Plus units it is recommended that a functional gas test is incorporated into the planned maintenance procedure for the unit. In most applications and installations, a planned maintenance / service interval of 1 year is appropriate, although this will depend upon site conditions and requirements. EN50073 and national regulations should be observed.

Where site operating procedures or regulations require routine calibration of gas detectors, this is possible using the SHC-1 Handheld Interrogator and the gassing cover. Care needs to be taken in order to ensure that routine field calibrations do not reduce the calibration accuracy compared to the original factory calibration. (Factory calibration is performed in more controlled conditions than are readily achievable in the field.)

Functional gas testing and calibration are made considerably easier by use of the SHC-1 Handheld Interrogator. If an SHC-1 is not available, basic functional gas testing can be performed using just a multimeter to monitor the 4-20mA of the unit being tested.

CAUTION

Searchpoint Optima Plus is a robust, flammable gas detector, it is not an analyser. Where the performance or features of an analyser are required, an analyser should be used.

6. CALIBRATION

6.2 SHC-1 HANDHELD INTERROGATOR

The SHC-1 Handheld Interrogator is a portable, Intrinsically Safe (IS) device which can be used to calibrate, test and commission all of Honeywell Analytics Searchpoint and Searchline optical gas detection products. The SHC-1 interrogator communicates with detectors via a digital RS485 link. Electrically, this link can be made either by using the IS socket on the DVC100 / DX100 or by connecting the flying leads on the SHC Protection Device (04230-A-1025) to the appropriate junction box terminals.



WARNING

The IS certification of the SHC-1 Handheld Interrogator only remains valid if it is used in conjunction with the Termination Unit or the SHC Protection Device. Do not attempt to connect the SHC-1 interrogator directly to units, always use either the Termination Unit or the SHC Protection Device.

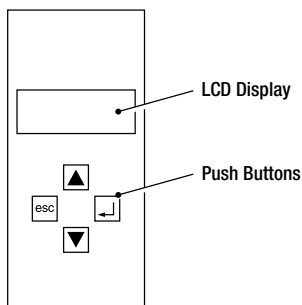

Hand-Held
Interrogator
Type SHC-1

Press \rightarrow and hold for three seconds to switch on.

Press \rightarrow and esc together and hold to switch off.

Unit powers down auto-matically after 10 minutes to prolong battery life.

6. CALIBRATION

6.2.1 Connecting the SHC-1 Hand-Held Interrogator

6.2.1.1 Termination Units

When using a Termination Unit, the SHC-1 Handheld Interrogator can be directly connected to the IS socket on the bottom of the Termination Unit.

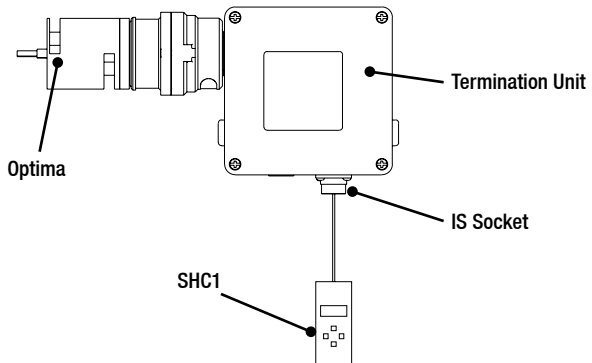

6.2.1.2 Other Junction Boxes (Use of SHC Protection Device)



WARNING

The SHC Protection Device can only be used in a safe area. ie. When a local safe area is achieved using a hot work permit or other appropriate gas free permit.

Interrogator connections to units mounted on junction boxes other than the DVC100 / DX100 can be made using the SHC Protection Device. The procedure for using the SHC Protection Device is as follows:-

- (1) Remove the cover to the respective junction box.

6. CALIBRATION

- (2) Connect the brown lead of the SHC Protection Device to the orange lead of the Optima communications link.
- (3) Connect the blue lead of the SHC Protection Device to the blue lead of the Optima communications link.
- (4) Connect the Hand-Held Interrogator SHC-1 to the SHC Protection Device connector.

Note: When transporting the SHC Protection Device in a hazardous area, the SHC Protection Device must be disconnected from the Hand-Held Interrogator.

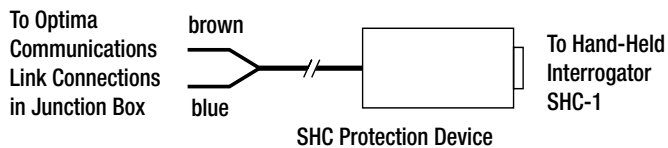

6.2.2 Hand-Held Interrogator Operating Modes

The Hand-Held Interrogator version 4v0 is compatible with Searchpoint Optima, Searchpoint Optima Plus and Searchline Excel. To work with a specific product the correct operating mode has to be selected as follows:

- (1) Press \downarrow to switch on the power.
- (2) The display will first show a title screen:

**Z - SHC 1 Optima
Interrogator 4v0**

The current operating mode is shown in the top right of the display.

- (3) Press **esc** and the display will show:

**Z - SHC 1 Optima +
Interrogator 4v0**

6. CALIBRATION

- (4) Press **esc** again and the display will show:



If **esc** is pressed again the operating mode will change to Optima and the different modes can be stepped through again.

- (5) When the display shows Optima + as the operating mode wait three seconds for the main menu to be displayed:



Note: 1. The current operating mode is remembered when the Hand-Held is switched off.

2. The operating mode can also be changed by selecting the change mode option on the main menu.

- (6) Press ▼ and the display will show:

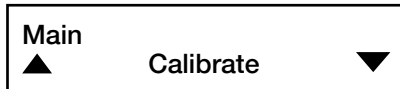

- (7) Press ▼ and the display will show:

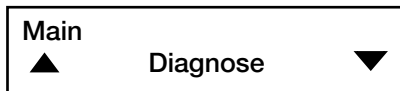

- (8) Press ▼ and the display will show:

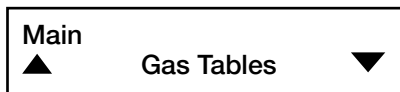

6. CALIBRATION

(9) Press ▼ and the display will show:

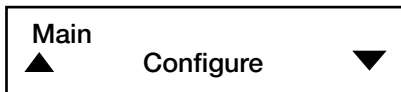

(10) Press ▼ and the display will show:

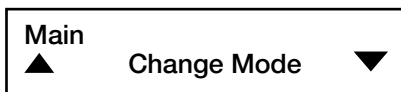

(11) Press ▼ and the display will show:



6. CALIBRATION

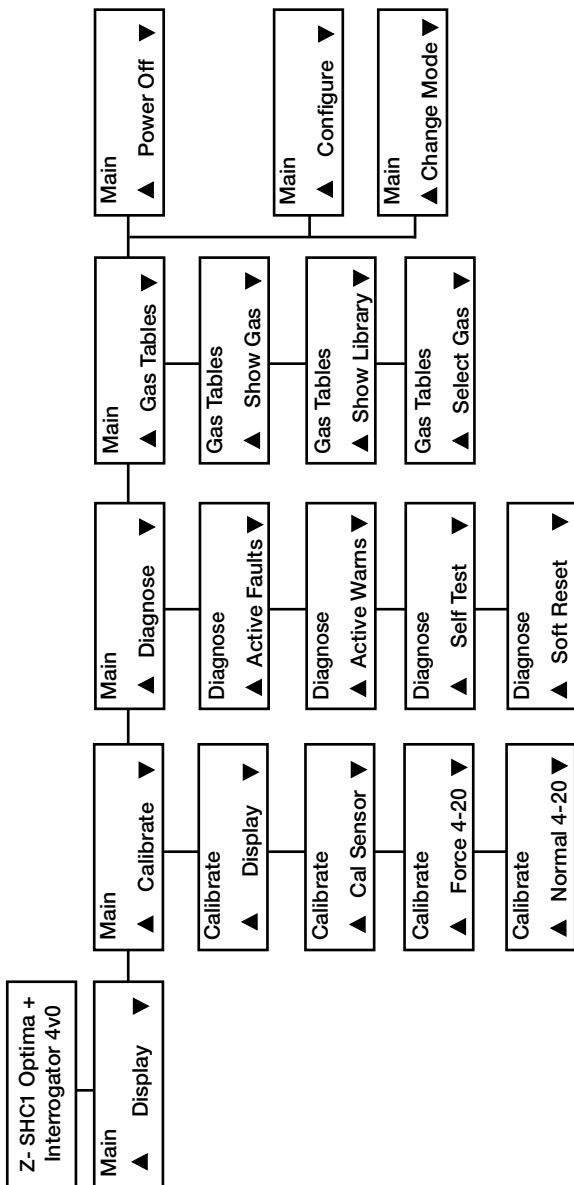

This diagram shows all the Hand-held Interrogator Software features. Use of the ▲ and ▼ keys to display the individual menu options. The options are selected by pressing ↵ and exited by press esc.

SHC-1 Hand-held Calibrator Menu Structure

6. CALIBRATION

6.2.3 Other Hand-Held Features

6.2.3.1 Display

Selecting this option from the main menu displays:

<p>Optima + Methane xx.x % LEL /</p>
--

The display shows the gas type, the gas reading and in the bottom right a status indicator:

- / Rotating bar indicates a healthy active unit.
- F indicates an active fault condition.
- W indicates an active warning.
- A indicates a gas concentration in excess of the units internal alarm threshold
- O indicates an active overrange.
- I indicates inhibit condition.

Pressing ▼ or ↵ changes the display to show:

<p>Optima + S/W 4v0</p>

The version of software currently installed within the Searchpoint Optima Plus unit.

Pressing ▼ , ▲ or ↵ will return the display to showing the current gas reading.

Pressing **esc** exits the display option to the main menu.

6. CALIBRATION

6.2.3.2 Calibrate

Display

The Display option on the Calibrate menu provides the same information as the Display option on the Main menu except the analogue output will be inhibited. This function is useful if a response check is to be carried out and you do not wish the gas reading to be reported on the analogue output.

Note: The rotating bar will not be shown on the gas reading display when the analogue output is inhibited.

Normal 4-20

This action releases the analogue output. It should be used if a communication error occurs while performing an operation with the Hand-Held which Inhibited the analogue output.

Note: The unit will release its analogue output automatically 10 minutes after it was Inhibited if no digital communication occurs.

6.2.3.3 Diagnostics

Active Faults/Active Warning

Selecting one of these actions displays any fault or warning conditions which are present in the unit. If more than one condition is simultaneously present, these may be scrolled through by pressing the ▲ or ▼ keys.

FAULT conditions prevent the unit from working as a gas detector and are always signalled on the analogue output as 0mA.

6. CALIBRATION

WARNING conditions indicate that the unit is operating close to the limits of its specified operating envelope. The unit may go into fault in the near future. If a fault condition is present in the unit while the active warnings are being displayed, the top line of the display will show Fault Present. Correct the Fault condition first.

A list of fault and warning conditions and the actions which should be taken to correct the problem are given in section 8.

Self Test

This action instructs the unit to complete a self test cycle. If a fault or warning condition was found in the unit, the Hand-Held display will show:

<p>Error 13 Error in Unit</p>

Details of the fault or warning can be viewed by selecting the Active Fault/Active Warning menu option.

Soft Reset

Selecting this option forces the unit to reboot. It is equivalent to switching the power to the unit off and then on.

6.2.3.4 Gas Table

The Show Gas menu option displays the current gas type. The Show Library action displays the part number and issue of the data base within the unit which contains the details of the different gasses which can be detected.

The Select Gas menu option allows the gas type of the unit to be changed. The gas types available on the standard unit are listed in Section 11.1.

The unit is inhibited while this action is performed. The unit should be calibrated after the gas type is changed.

6. CALIBRATION

6.2.3.5 Config

The Show Config option on the Config menu shows the values of a number of key parameters in the Searchpoint Optima Plus. These may be scrolled through by pressing the ▲ or ▼ keys.

Optima Plus Configuration Parameters

Configuration Parameters	Parameter Title	Purpose
Auto Zero	Zero Tracking	Enables automatic zero tracking function within the unit. Used only in specialist applications, function is normally disabled.
Alarm Threshold	Alarm Threshold	Sets a gas concentration threshold (adjustable over the range 10% to 50% full scale, default 25%) beyond which the unit considers a dangerous level of gas is present. A fault will be signaled if the output current can not be driven to a value in excess of this threshold.
Inhibit Current	Inhibit mA	Defines the output current for Inhibit condition.
Warning Current	Warning mA	Defines the output current when a warning is present.
Overrange Current	Overrange mA	Defines the output current when the gas concentration exceeds full scale.
Protocol Address	Digital Address	Defines the protocol address of the unit when connected into a multi-drop digital network. Used only in specialist applications.

6.2.3.6 Power Off

Entering this menu and pressing ↵ turns off the Hand-held Interrogator to preserve battery life.

6. CALIBRATION

6.3 CALIBRATING THE CONTROLLER

This procedure allows the user to calibrate the controller by FORCE'ing a known current out of the unit's 4-20mA output. Use of this technique enables calibration of the controller's 0-100% fsd scale without the need for gas. The output can be forced in the range 1.0 to 21mA (0.1mA resolution).

It is recommended that calibration of the controller is performed at two points, ideally 4mA (0.0% fsd) and 12mA (50% fsd). Provided that no background gas concentration is present, the unit's 4mA (0.0% fsd) output can be used to calibrate the control cards zero point. The span calibration of the controller can then be calibrated by FORCE'ing the required current as follows:-

- (1) Connect the Hand-Held Interrogator to the unit.
- (2) Press \downarrow to switch the power on, ensure the Hand-held is in Optima + mode and wait five seconds.
The display will show:



- (3) Press ▼ and the display will show:

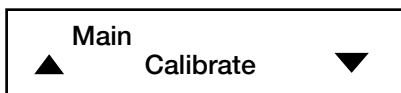

- (4) Press \downarrow and the display will show:



6. CALIBRATION

- (5) Press ▼ and the display will show:

Calibrate
▲ Cal Sensor ▼

- (6) Press ▼ and the display will show:

Calibrate
▲ Force 4-20 ▼

This selects the FORCE'd 4-20mA routine which can be used to calibrate the controller.

- (7) Press ↵ and the display will show:

O/P 4-20 current
▲ 4.0 mA ▼

- (8) Press ▲ or ▼ to change the displayed mA value in 0.1mA steps:

O/P 4-20 current
▲ 12.0 mA ▼

Choose the desired value.

- (9) Press ↵ and the display will show:

Fixed: nn.nn mA
Press enter

where nn.nn is the current measured by the Optima Plus diagnostic function. The analogue output is now set to the selected value set in step (8). Specified accuracy is $\pm 1\%$ FS ($\pm 0.2\text{mA}$).

6. CALIBRATION

- (10) Calibrate the controller to display the correct reading for the current being FORCE'd on the 4-20mA output.
- (11) Press **↵** and the display will show:

**Press Enter To
Release 4 - 20**

Note: The unit will return to normal operation after 10 minutes if no key is pressed.

- (12) Press **↵** and the display will show for 3 seconds:

4 - 20 Released

The analogue output has now returned to normal operation.

- (13) Wait and the display will show:

Calibrate
▲ Force 4-20 ▼

Returns to the Calibrate Menu.

- (14) Press **esc** twice to return to the Main Menu:

Main
▲ Display ▼

- (15) The Hand-Held Interrogator may be switched off by pressing **esc** and **↵** together.

6. CALIBRATION

6.4 CALIBRATING THE SENSOR

CAUTIONS

1. Searchpoint Optima Plus is supplied factory calibrated for a particular hydrocarbon gas and should not require routine gas calibration. In general, this factory calibration will be more accurate than what can be achieved in the field. Only perform gas calibration if this is required by local regulations or if there is clear evidence of a significant calibration error. In most instances, the zeroing and functional testing procedure described in Section 7 should be sufficient to maintain a unit's performance without the need for gas re-calibration.
2. Ensure that the correct calibration gas and concentration are used. The concentration of calibration gas should be known to be accurate to within +/-2.5% of the value declared on the cylinder / bottle.
3. It is important to present the calibration gas correctly to the detector. Only use Searchpoint Optima Plus gassing accessories as directed.
4. Searchpoint Optima, in common with other IR gas detectors, measures the total number of target gas molecules in it's beam and hence readings are directly related to the gas pressure in the measurement path. Avoid pressurising calibration gas inside the unit's measurement path by keeping gas flow rates below the maximum recommended levels and ensuring that gas can freely vent to atmospheric pressure. The maximum recommended flow rates are 0.3 l / min for the remote gassing cell, 2 l / min for the gassing cover and 2 l / min for the flow housing.

6. CALIBRATION

5. Do not attempt to perform calibration during periods of exceptionally low or high atmospheric pressure. (Normally associated with unusual or extreme weather conditions. Calibration is not recommended during storms, very strong winds or highly changeable weather conditions.)
6. Ordinarily, during production Optima Plus units are calibrated with gas in the main measurement chamber, which is where they will detect gas in operational service. The response in the RGC is not production calibrated. The RGC is not recommended for calibration or for high accuracy calibration testing. (The only exception to this is where units are being used to measure high %V/V gases using the RGC as a flow cell. In this instance, the units are production calibrated with gas in the RGC.)
7. Always allow unit's to stabilise in the operating environment for at least 30 minutes (ideally 1 hour) before performing gas calibration.

Equipment Required:

Gassing Cover

Instrument Air (if a zero in ambient air cannot be guaranteed)

Calibration Span Gas (i.e. 2.2% V/V methane for 50% LEL output if working in accordance with EN61779)

SHC-1 Handheld Interrogator

6. CALIBRATION

To calibrate the sensor, proceed as follows:

- (1) Connect the Hand-Held SHC-1, press \downarrow to switch on the power, check the Hand-held is in Optima + mode, wait five seconds and the display will show:



- (2) Press \downarrow and the display will show:

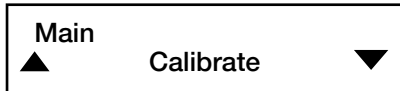

- (3) Press \downarrow and the display will show:



- (4) Press \downarrow and the display will show:

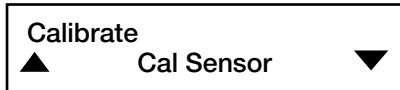

- (5) Press \downarrow and the display will show:

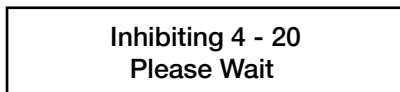

This sets the analogue output to the inhibit level (default 2mA) for the duration of the calibration sequence.

- (6) Remove weather protection and dust barrier. Check that the optics are clean and dry. Clean / dry optics if necessary. Refit the dust barrier and weather protection.

6. CALIBRATION

- (7) Wait and the display will show:

**Ensure Zero Gas
Press Enter**

Note: If at this stage the zero reading in ambient air cannot be guaranteed, fit the gassing cover over the weather protection and apply instrument air at one litre/minute for 30 seconds.

- (8) Press ↵ and the display will show:

**Processing Data
Please wait**

After 10s the display will show:

Zero Calibrated

The new baseline (zero) is now set.

- (9) Wait and the display will show:

**Cal Span, Enter
Exit Cal, ESC**

- (10) Either:

- a. press **esc** to end the calibration sequence without carrying out a span calibration, or
- b. press ↵ and the display will show:

**Press Enter To
Select Gas Conc.**

6. CALIBRATION

This means set the gas concentration (ie. 50% LEL: for 2.2% methane if working in accordance with EN61779).

- (11) Press \downarrow and the display will show:

Span Gas 50.0 % LEL

- (12) Press \blacktriangle or \blacktriangledown to change the displayed gas value between 30 and 125%LEL (1% steps) to the value being applied.

- (13) Press \downarrow and the display will show:

Press Enter when Stable: xx.x
--

- (14) Fit the gassing cover over the weather protection of the Searchpoint Optima.
- (15) Apply span calibration gas at a rate of one litre/minute and wait for reading to stabilise. This will take approximately 30 seconds to 1 minute, depending upon flow rate.

Press Enter when Stable: xx.x
--

- (16) Press \downarrow and the display will show:

Processing Data Please wait
--

After 10s the display will show:

Span Calibrated

6. CALIBRATION

- (17) Wait and the display will show:

Remove gas, Press
Enter: xx.x

- (18) Remove the gassing cover from the weather protection. Ensure the reading has returned to 00.0% LEL.

- (19) Press ↵ and the display will show:

Press Enter To
Release 4 - 20

Releases the analog output from 2mA (inhibit signal) to normal operation (4mA).

- (20) Press ↵ and the display will show for 3 seconds:

4 - 20 released

The analogue output has now returned to normal operation.

- (21) Wait and the display will show:

Calibrate
▲ Cal Sensor ▼

Returns to the Calibrate Menu.

- (22) Press **esc** twice to return to the Main Menu:

Main
▲ Display ▼

6. CALIBRATION

- (23) The Hand-Held Interrogator may be switched off by pressing esc and ↵ together.

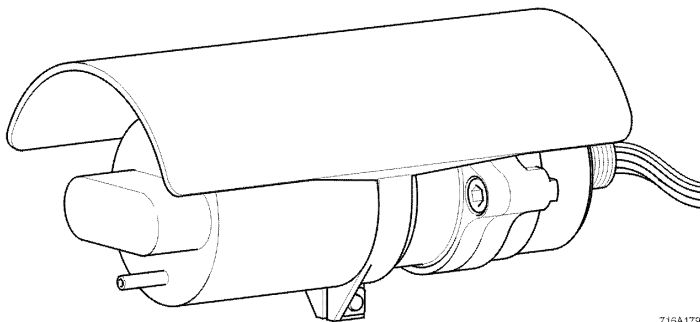

716A179

Gassing Cover Fitted Over Weather Protection

7. ROUTINE CHECKS

7.1 GENERAL

Searchpoint Optima Plus is designed to require minimal routine maintenance and testing during use. Installed and operated correctly, the only maintenance actions required should be occasional cleaning and re-zeroing.

Continuous self-diagnostics ensure that if a unit develops a problem, this is reported as a FAULT or WARNING. Warnings are reported by a default signal of 3 mA (configurable). Provided that a unit is reporting 4mA (or a configured WARNING signal) it is an active gas detector.

Inspection and maintenance intervals vary depending upon local regulations and requirements. EN50073 and national regulations should be observed. If no specific requirements exist, it is recommended that units are inspected and functionally tested at twelve monthly intervals. Details of the recommended routine inspection and functional test procedure are presented in Section 7.2

7.2 INSPECTION AND FUNCTIONAL RESPONSE CHECK PROCEDURE

The recommended procedure for inspecting and functionally testing Searchpoint Optima Plus units is detailed below:-

Equipment Required:-

Gasping Cover (or Calibration Cap)

Test Gas (normally equivalent to 50% fsd)

SHC-1 Handheld Interrogator

Cleaning materials (soft cloth or cotton buds, mild detergent or window cleaner)

- (1) Inspect the Searchpoint Optima Plus unit, it's junction box and cabling for any signs of physical damage.

7. ROUTINE CHECKS

- (2) Connect the SHC-1 interrogator to the unit.
- (3) INHIBIT the unit by selecting the DISPLAY option in the CALIBRATE menu.
- (4) Unscrew the two retaining nuts and remove the Standard Weather Protection. Inspect the Standard Weather Protection for damage or build up of debris / contaminants. If required, clean or replace weather protection.
- (5) Inspect the Dust Barrier and clean or replace if required.
- (6) Remove the Dust Barrier and inspect the optics.
- (7) Clean any dust or contaminants from the optics using mild detergent or window cleaner and a soft cloth or cotton bud.

Note: If a remote gassing cell is fitted, the cell window can be unscrewed and removed for cleaning purposes where necessary. When replacing, ensure that the cell window is fully screwed home (the effective thickness of the gassing cell is reliant upon this).

CAUTIONS

1. Do not attempt to clean the optics using abrasive or corrosive materials.
2. Do not attempt to clean the unit using a sand-blaster or similar equipment.
3. Do not use concentrated organic solvents to clean the unit. These substances contain hydrocarbons which may give rise to gas readings when they evaporate.

7. ROUTINE CHECKS

- (8) Refit or replace the Dust Barrier and Standard Weather Protection.
- (9) Verify that there are no ACTIVE FAULTs or WARNINGs by checking that the '/' line is present on the right side of the CALIBRATE / DISPLAY screen. If there are FAULTs or WARNINGs, the '/' will be replaced with either an F or a W.
- (10) If ACTIVE FAULTs or WARNINGs are present, investigate these by using the DIAGNOSTIC menu options. Wherever possible, correct any ACTIVE FAULTs or WARNINGs before proceeding to the next stage.

Having completed the above steps, you are now ready to perform a functional response check. Functional response checks can either be performed using the Gassing Cover and %LEL concentration gas or using the Remote Gassing Cell and high %V/V gas. The procedures for performing functional response checks are described in the following sections.

7.2.1 Response Check Using Gassing Cover and %LEL Concentration Gas

Note: For best results when performing functional response checks it is important to re-ZERO a unit before the response check.

- (1) For best results, allow the sensor to remain under power for one hour prior to performing response check. This allows the unit's temperature to stabilise in the operating environment.
- (2) Fit the Gassing Cover over the weather housing, ensuring the gas entry slot at the base of the standard weather protection is covered.

7. ROUTINE CHECKS

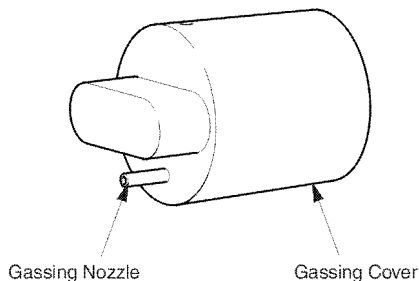

716A177

- (3) Ensure that there is a suitable zero gas inside the unit's main measurement chamber and the remote gassing cell (if fitted). Suitable zero gases include fume/vapour-free atmospheric air, instrument air and nitrogen. (In most outdoor or well ventilated installations, atmospheric air will suffice for zeroing. Instrument air or nitrogen should only be necessary for poorly ventilated installations or where a significant hydrocarbon background is present or expected.)
- (4) Select the CALIBRATE / CAL SENSOR menu option and re-zero the unit. (Do not re-calibrate the unit's span gas response.)
- (5) Select the CALIBRATE / DISPLAY menu option.
- (6) Using the Gassing Cover, apply test gas to the unit. Allow approximately 30 seconds to 1 minute for the gas concentration in the measurement chamber to stabilise.
- (7) Monitor the DISPLAY'ed gas reading and confirm that it is within +/-5% LEL of the anticipated reading. If the reading is within +/- 5% LEL of what is anticipated, the unit is definitely operating correctly. Do not consider re-calibrating units with apparent "calibration errors" less than +/- 5% LEL. Be aware that field calibration

7. ROUTINE CHECKS

and response checking techniques are not sufficiently accurate to determine whether such small “errors” are genuine, or to correct them.

- (8) If the DISPLAY’ed gas reading is within +/-10% fsd of the anticipated reading, it is possible that there might be a calibration error but it is still more likely that the error will be due to the prevailing conditions or test gas / technique. Before considering re-calibration, double-check the following:-
- a. The optics are clean and un-contaminated.
 - b. The unit has been correctly zeroed in a genuine zero gas background.
 - c. The correct test gas and concentration are being used for the range being tested.
 - d. The tolerance on the test gas concentration is significantly less than the apparent reading error.
 - e. There is adequate test gas in the cylinder.
(Cylinders that are nearly empty tend to read on the low side.)
 - f. The test gas in the measurement chamber / remote gassing cell is not being pressurised due to high flow rates or blockages / restrictions.
 - g. The atmospheric pressure is not unusually high or low.
 - h. The unit has had sufficient time to stabilise in it’s operating environment. (At least 30 minutes, ideally 1 hour after any significant change or power-up.)
 - i. An approved, Honeywell Analytics supplied gas testing accessory is being used. (Either the gassing cover, calibration cap or the remote gassing cell.)

7. ROUTINE CHECKS

If after checking the above, the error remains, consider re-calibrating the unit in accordance with the procedure detailed in Section 6.4.

- (9) Errors in the DISPLAY'ed gas reading larger than +/- 10% fsd are rare. Where encountered, they are more likely to be associated with the considerations listed in (8) for double-checking than errors in the actual unit's calibration. Ensure that all of the considerations are fully checked before re-calibrating. If the apparent calibration error is larger than +/-15% fsd, contact Honeywell Analytics or their representatives for advice before attempting re-calibration.
- (10) Before releasing the detector from INHIBIT, ensure that any test gas inside the unit's measurement chamber has been fully removed. This can be achieved either by blowing instrument air / nitrogen through the Gassing Cover, or by removing the Gassing Cover and allowing the test gas to escape (this takes around 30 seconds).
- (11) Release the detector from INHIBIT by selecting the MAIN DISPLAY menu option.
- (12) Provided that on the MAIN DISPLAY, the unit is reading 0.0% LEL and the '/' line is rotating, the unit is operating normally and all tests and maintenance activities have been completed.

If the '/' line has been replaced by a W, there is an ACTIVE WARNING in the unit, which should be investigated and where possible cleared before leaving the unit for operational use.

If the '/' line is not rotating or has been replaced by an F, there is an ACTIVE FAULT. The unit will not operate with an ACTIVE FAULT. Use the DIAGNOSTICS menu option to identify the cause of the FAULT and remedy where possible.

7. ROUTINE CHECKS

- (13) Disconnect the SHC-1 interrogator from the unit.
- (14) The functional response check has been completed

7.2.2 Response Check Using Remote Gassing Cell & High %V Gas

- Note:*
1. *This only applies if the optional Remote Gassing Cell has been selected and fitted.*
 2. *The Remote Gassing Cell is designed to facilitate functional response checking of units installed in positions where obtaining access is difficult. The RGC is not recommended for calibration or for high accuracy calibration testing. During production, Optima Plus units are calibrated with gas in the main measurement chamber, which is where they will detect gas in operational service. The response in the RGC is not production calibrated. (The only exception to this is where units are being used to measure high %V/V gases using the RGC as a flow cell. In this instance, the units are production calibrated with gas in the RGC.)*
 3. *The functional response check limits recommended for this procedure include reasonable allowances for the effects of atmospheric pressure, test gas tolerances and test repeatability. These functional response check limits are representative of what the user should expect to achieve under typical field conditions.*
 4. *This procedure assumes the Searchpoint Optima Plus has been calibrated for 0 - 100% LEL methane.*

7. ROUTINE CHECKS



CAUTIONS

1. In order to avoid pressurisation, gas should flow through the remote gassing cell at no more than 0.3 litre/min.
2. Ensure that the exhaust pipe is not blocked since this may pressurise the flow through the cell and may cause permanent damage to the unit.
3. Never blow air from the lungs directly into the remote gassing cell since the presence of any foreign substances within the cell will adversely affect the operation of the unit.
4. Always use a Flow Filter on the inlet of the remote gassing cell when a remote gassing pipe is permanently installed.
5. For other gases, contact Honeywell Analytics Limited.

7. ROUTINE CHECKS

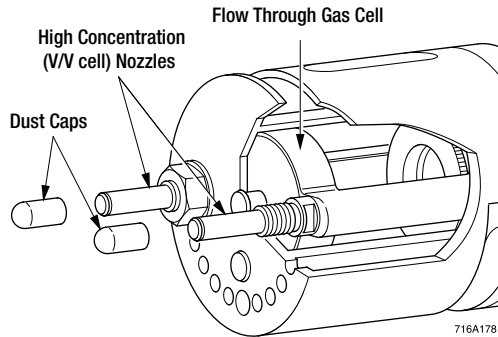

Equipment Required:

Flow Through Cell Gassing Kit, consisting of:

Lengths of plastic tube with In Line Particle Filter.
Cylinder of 50% v/v Methane.
Cylinder of nitrogen (zero gas).
Exhaust Pipe (at least one metre of plastic tube).
Multimeter.

- (1) Remove the dust caps from the two pipes / tubes leading to the Remote Gassing Cell Nozzles. (Whilst the RGC is not being used for response checking, the pipes / tubes leading to the RGC should be sealed to prevent dirt / moisture ingress into the RGC. It is assumed that the dust caps supplied fitted to the gassing cell nozzles will be used for this purpose.)
- (2) Connect the outlet from the zero gas cylinder to the pipe / tube leading to the RGC.
- (3) Ensure that the exhaust pipe / tube coming from the RGC is clear and that it vents well away from the Searchpoint Optima. (If concentrated %V/V gas leaving the exhaust pipe / tube gets into the main measurement chamber it will significantly affect the readings obtained when using the RGC.)

7. ROUTINE CHECKS

- (4) Flush the RGC with zero gas for at least 30 seconds.
- (5) Select the CALIBRATE / CAL SENSOR menu option and re-ZERO the unit. (Do not re-calibrate the unit's span gas response.)
- (6) Disconnect the zero gas and connect the high concentration %V/V span test gas to the pipe / tube leading to the RGC.
- (7) Apply 50%V/V methane to the RGC at a flow rate of 0.3 litres / minute.
- (8) Allow approximately 30 seconds to 1 minute for the gas concentration in the RGC to stabilise.
- (9) Monitor the DISPLAY'ed gas reading and confirm that it is within +/-10% LEL of the anticipated reading (57.5%LEL +/- 10%LEL for 50%V/V methane in the RGC.). If the reading is within +/- 10% LEL of what is anticipated, the unit is operating correctly. Do not consider re-calibrating units with apparent errors less than +/- 10% LEL. Be aware that field calibration and response checking techniques using the RGC are not sufficiently accurate to determine whether such errors are genuine, or to correct them.
- (10) If the DISPLAY'ed gas reading differs from the anticipated reading by more than +/- 10% LEL, it is possible that there might be a calibration error but it is still more likely that any errors will be due to the prevailing conditions, test gas or gassing technique. Before considering re-calibration, double-check the following:-
 - a. The optics are clean and un-contaminated.
 - b. The unit has been correctly zeroed in a genuine zero gas background.

7. ROUTINE CHECKS

- c. The correct test gas and concentration are being used for the range being tested.
- d. The tolerance on the test gas concentration is significantly less than the apparent reading error.
- e. There is adequate test gas in the cylinder.
(Cylinders that are nearly empty tend to read on the low side.)
- f. The test gas in the measurement chamber / remote gassing cell is not being pressurised due to high flow rates or blockages / restrictions.
- g. The atmospheric pressure is not unusually high or low.
- h. The unit has had sufficient time to stabilise in it's operating environment. (At least 30 minutes, ideally 1 hour after any significant change or power-up.)
- i. An approved, Honeywell Analytics supplied gas testing accessory is being used. (Either the gassing cover, calibration cap or the remote gassing cell.)

If after checking the above, the error remains, consider re-calibrating the unit in accordance with the procedure detailed in Section 6.4.

- (11) Before releasing the detector from INHIBIT, ensure that any test gas inside the unit's RGC has been fully removed. This can be achieved by blowing instrument air / nitrogen through the RGC for approximately 1 minute.
- (12) Re-seal the pipes / tubes leading to the RGC using the dust caps provided (or a suitable alternative).
- (13) Release the detector from INHIBIT by selecting the MAIN DISPLAY menu option.

7. ROUTINE CHECKS

- (14) Provided that on the MAIN DISPLAY, the unit is reading 0.0% LEL and the '/' line is rotating, the unit is operating normally and all tests and maintenance activities have been completed.

If the '/' line has been replaced by a W, there is an ACTIVE WARNING in the unit, which should be investigated and where possible cleared before leaving the unit for operational use.

If the '/' line is not rotating or has been replaced by an F, there is an ACTIVE FAULT. The unit will not operate with an ACTIVE FAULT. Use the DIAGNOSTICS menu option to identify the cause of the FAULT and remedy where possible.

- (15) Disconnect the SHC-1 interrogator from the unit.
- (16) The functional response check has been completed.

7.3 INSPECTION AND TESTING OF UNITS INSTALLED IN DUCTS

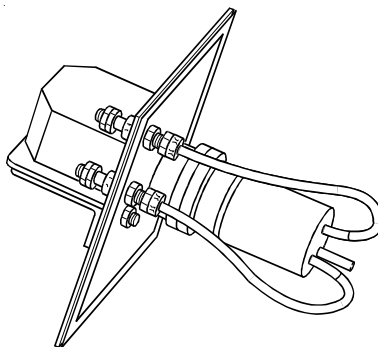

Obtaining access to units mounted in ducts can be more difficult than for units in open installations. Ideally, one would wish to perform all inspection and testing activities without removing units or their mounting plates from the duct wall.

7. ROUTINE CHECKS

The duct mounting kit makes it possible to interrogate and functionally gas test units in-situ, which covers most recommended maintenance and testing activities. However, it is not possible to inspect or clean a unit whilst it is inside the duct. The requirement to inspect and clean a unit varies depending upon the conditions inside the duct:-

- a. **Clean / Dry Ducts:** Where the conditions inside a duct are clean and dry, the likelihood of contaminant or condensation build-up on the dust barrier or optics is relatively low. Provided that a unit is not reporting any FAULTs or WARNINGs, it should not be necessary to physically inspect it. Typical clean / dry duct installations include filtered, onshore HVAC inlets and outlets from clean plant / building areas.
- b. **Dirty / Damp Ducts:** Where the conditions inside a duct are dirty or damp, the likelihood of contaminant or condensation build-up on the dust barrier or optics is significantly increased. It is therefore strongly recommended that units are temporarily de-mounted from the duct in order to perform inspection and cleaning. Typical dirty / damp duct installations include offshore HVAC inlets and un-filtered plant / building inlets.

The procedure for testing and inspection of units installed in ducts is essentially the same as that described in Section 7.2.

7. ROUTINE CHECKS

7.4 REMOVAL AND REFITTING OF FLOW HOUSING

7.4.1 Removal of Flow Housing

Before the inspection check can be carried out on a Searchpoint Optima Unit fitted with a Flow Housing, the Flow Housing must be removed as follows:

- (1) Disconnect any pipework attached to the flow housing.
- (2) Using a ½ inch A/F open ended spanner, remove the two black nuts which retain the flow housing. Keep the O-ring seals which are below the retaining nuts.
- (3) Slide the flow housing off the Optima. NB: This may require some force due to the friction of the O ring.
- (4) The window and mirror can now be inspected and cleaned if necessary.

7.4.2 Refitting of Flow Housing

To refit the flow housing, proceed as follows:

- (1) Check the window and mirror are free from contamination.
- (2) Ensure that the large sealing O ring, in the body of the flow housing, and the two small O rings, which go below the retaining nuts, are clean and in good condition. Replace if in doubt.
- (3) Slide the flow housing over the end of the Searchpoint Optima and push until the flow housing is firmly seated.

7. ROUTINE CHECKS

- (4) Place the small O-rings on the threaded pipes which are used to secure the flow housing. Fit the retaining nuts to the threaded pipes and tighten them down.
- (5) Ensure that the main seal and the seals below the retaining nuts are fully compressed and providing a good seal.
- (6) Reconnect any pipework that was attached to the flow housing.

8. FAULT FINDING

8.1 TROUBLESHOOTING

The table below describes some possible faults and problems that can be encountered and their most likely causes and remedies. The user should be aware that there are often significant differences between what appears to be the problem and the actual problem when fully diagnosed. Experience has shown that a methodical, whole-system orientated approach is the most effective for solving problems with gas detection systems and installations.

Fault / Problem	Cause / Remedy	
Output is 0mA	Cause:	Unit is in FAULT condition
	Remedy:	Connect SHC-1 interrogator to unit and use DIAGNOSTIC menu options to ascertain reason for FAULT report.
	Cause:	Electrical installation problem.
	Remedy:	(1) Check +24V power supply to unit. (2) Check cables and connections, especially 4-20mA loop connections. (3) Check that unit has correct 4-20mA output configuration for use with the controller.
	Cause:	Optical surfaces are obscured by dirt / contaminants.
	Remedy:	Clean optical surfaces.
	Cause:	Unit's zero position has negative offset.
	Remedy:	Check that optics are clean and dry. Re-zero unit.

8. FAULT FINDING

Fault / Problem		Cause / Remedy
Output is 0mA	<p>Cause:</p> <p>Remedy:</p>	<p>Unit has developed an electrical fault.</p> <p>Most electrical faults result from damage caused by site / installation problems. Check for correct wiring, voltage spikes / transients, power surges and earthing problems.</p>
Unit fails to respond to SHC-1 Handheld Interrogator	<p>Cause:</p> <p>Remedy:</p> <p>Cause:</p> <p>Remedy:</p> <p>Cause:</p> <p>Remedy:</p> <p>Cause:</p> <p>Remedy:</p> <p>Cause:</p> <p>Remedy:</p> <p>Cause:</p> <p>Remedy:</p>	<p>Incorrect connection of interrogator's communication link.</p> <p>Check that the SHC-1 is correctly plugged into IS socket or that SHC Protection Device leads are connected to the right junction box terminals.</p> <p>Incorrect software version in Handheld Interrogator.</p> <p>Optima Plus only works with version 3V0 interrogator software <u>and above</u>. Check interrogator software version.</p> <p>No power applied to Optima Plus unit.</p> <p>Check +24V power supply to unit.</p> <p>Incorrect mode selected on interrogator.</p> <p>Select Optima + mode on interrogator.</p> <p>Battery failed in Handheld Interrogator.</p> <p>Check / replace interrogator battery.</p>

8. FAULT FINDING

Fault / Problem		Cause / Remedy
Unit does not respond to test gas.	<p>Cause:</p> <p>Remedy:</p>	<p>If unit is sending 4mA (active), this is more likely to be a problem with the test gas or gassing technique than with the unit.</p> <p>(1) Check that the functional gas test procedure is being performed correctly. (See Section 7.2)</p> <p>(2) Check that correct test gas and concentration are being used.</p> <p>(3) Check that the gas cylinder is not empty.</p> <p>(4) Check that any gas tubing or inlet pipes used are not broken or blocked.</p> <p>(5) Check that the unit is not in FAULT (0mA) or FORCE'd to a particular 4-20mA output current.</p>
Unit does not produce the predicted response to test gas.	<p>Cause:</p> <p>Remedy:</p> <p>Cause:</p> <p>Remedy:</p>	<p>Problem with test gas or gassing technique.</p> <p>(1) Check that the functional gas test procedure is being performed correctly. See Section 7.2, paying particular attention to items 15) to 17). (Also see Section 6.4 CAUTIONS.)</p> <p>(2) Check that the correct test gas and concentration are being used.</p> <p>Calibration error or span drift.</p> <p>If certain that the gas and gassing technique are correct and that any discrepancy is due to the unit's calibration, re-calibrate the unit in accordance with Section 6.4.</p>

8. FAULT FINDING

Fault / Problem		Cause / Remedy
<p>Unit's output appears to be drifting.</p>	Cause:	Correct response to genuine, low level fluctuations in gas concentration where the unit is installed.
	Remedy:	A commonly misinterpreted problem which is resolved when the source of the fluctuating gas leak is finally identified. If a unit is transmitting a gas reading, double-check the gas concentration at the <u>exact</u> point where the detector is installed using a sensitive portable gas detector that has been carefully zeroed. (Do not use a standard catalytic detector on a 0-100% LEL range, they are not sensitive enough to reliably detect low % LEL concentrations.)
	Cause:	Build-up of contaminants on optics, especially oil-mist, exhaust fumes, grease and solvents.
	Remedy:	Check that dust barrier is fitted correctly, clean and intact. Closely inspect the optics to be sure that nothing is building up on them. Clean and re-zero unit if necessary.
	Cause:	Exposure of unit to extreme temperatures.
	Remedy:	Check unit's FAULT / WARNING log to see if it has records of Temp Lim Exceeded. If temperature problems are confirmed, either relocate or shield the detector or consider use of a sampling system.

8. FAULT FINDING

Fault / Problem		Cause / Remedy
<p>Unit's output appears unstable and erratic.</p>	<p>Cause:</p> <p>Remedy:</p>	<p>Electrical interference being directly introduced onto 4-20mA cabling.</p> <p>Connect an oscilloscope between the 4-20mA input and the 0V at the control card and look for noise on the signal. (A Technical Note is available describing the measurement and interpretation of noise on 4-20mA cabling.) Be aware that where present, this noise does not come from the unit, nor as a result of electrical interference effecting the unit, it is being introduced directly onto the cabling.</p> <p>Causes of electrical interference in industrial and commercial installations vary widely. Section 4. details precautions and recommendations that should be taken into account when engineering the electrical installation for a gas detection system. Provided that these are adequately addressed, electrical noise on the 4-20mA cabling should not be a problem.</p> <p>If an installation is noisy but cannot be improved due to safety regulations or cost, some improvements can be achieved by paying attention to control card filtering and signal processing. For gas detection applications, 4-20mA bandwidths should be filtered down to a few Hertz and signal averaging and transient rejection algorithms should be used.</p>

8. FAULT FINDING

Fault / Problem		Cause / Remedy
<p>Unit's output appears unstable and erratic. (cont.)</p>		<p><i>Note: These filtering and processing measures are not typically taken on standard PLC inputs / systems and this has led to problems when such systems are used for gas detection applications.)</i></p> <p>Cause: Unit has developed an electrical fault.</p> <p>Remedy: Most electrical faults result from damage caused by site / installation problems. Check for correct wiring, voltage spikes / transients, power surges and earthing problems. Correct any electrical installation problems. Return unit to Honeywell Analytics for repair.</p> <p>Cause: Unit is experiencing an intermittent fault or is fluctuating about the FAULT / WARNING threshold for a particular diagnostic test.</p> <p>Remedy:</p> <ol style="list-style-type: none"> (1) Check the unit's FAULT / WARNING log to find clues as to what might be causing the intermittent or fluctuating fault condition. (2) Check that the optics are clean and dry and that no foreign objects are moving in the measurement chamber. (3) If no cause for the intermittent behaviour can be identified, return the unit to Honeywell Analytics for further investigation and / or repair.

8. FAULT FINDING

8.2 DIAGNOSIS OF WARNING AND FAULT MESSAGES

The table below describes the WARNING and FAULT messages which can be reported by a unit when the DIAGNOSTIC menu options are used on the Handheld Interrogator. Where possible, appropriate remedial actions to clear these WARNINGS and FAULTS are identified. Note: If the remedial action is successful, the warning or fault will automatically clear.

SHC-1 Handheld Text	Description	Remedial Action(s)
W-See Inst Guide Temp Lim Exceeded	<p>WARNING:</p> <p>Specified operating temperature limits nearly exceeded. (High or low.)</p> <p>FAULT:</p> <p>Specified operating temperature limits have been exceeded. (High or low.)</p>	<p>(1) Relocate the unit away from any intense sources of heat or cold.</p> <p>(2) Shield the unit from intense sources of heat or cold.</p> <p>(3) Install the unit in a sampling system.</p> <p>Once the unit has been operated outside of it's specified and certified operating temperature range, it's certification and warranty are invalidated. Remove the unit from service and permanently dispose of it. (Honeywell Analytics cannot repair or re-work equipment that has been exposed to conditions outside of it's certified range.)</p> <p><i>Employ suitable measures to ensure that this problem does not recur. See (1) to (3) above.</i></p>

8. FAULT FINDING

SHC-1 Handheld Text	Description	Remedial Action(s)
<p>W-See Inst Guide Bad 24V Supply</p>	<p>WARNING: The 24V supply voltage is just outside of the specified limits. (18V to 32V)</p> <p>FAULT: The 24V supply voltage is well outside of the specified limits. (<16V or >34V)</p>	<p>(1) Check the 0V and 24V connections and cabling to the unit.</p> <p>(2) Verify that the round-trip resistance of the supply cable is less than 25.5 ohms.</p> <p>(3) Check that the supply voltage at the controller is at least 24V.</p> <p>(4) Take appropriate measures to ensure that the supply voltage reaching unit is between 18V and 32V.</p> <p>See (1) to (4) above.</p>
<p>W-See Inst Guide Bad 4-20mA Loop</p>	<p>WARNING: The 4-20mA monitoring system has detected a current error greater than +/- 0.5mA.</p>	<p>(1) Check the 4-20mA loop connections and cabling.</p> <p>(2) Check that the loop resistance is less than 600 Ohms.</p>

8. FAULT FINDING

SHC-1 Handheld Text	Description	Remedial Action(s)
<p>W-See Inst Guide</p> <p>Bad 4-20mA Loop</p>	<p>FAULT: The unit is unable to transmit a current which represents a gas concentration in excess of the units internal alarm threshold</p>	<p>(3) Check the 4-20mA output of the unit as described in Section 5.2</p> <p>In addition to the above, check that the unit's 4-20mA output is correctly configured for the controller input.</p>
<p>W-See Ops Guide</p> <p>Lamp Output</p>	<p>WARNING: One of the lamps' output has been diagnosed as being close to the minimum operating limit.</p>	<p>(1) Clean the optics. If this WARNING does not clear, the unit's diagnosis of low lamp output is probably correct.</p> <p>(2) If convenient, replace the Optima Plus unit with a spare and return it to Honeywell Analytics for service or repair. Alternatively, wait for the lamp output to fall below the minimum operating limit, at which point the unit will signal a FAULT. (This will probably happen within the following 12 months.)</p>

8. FAULT FINDING

SHC-1 Handheld Text	Description	Remedial Action(s)
W-See Ops Guide Lamp Output	FAULT: The lamp output has fallen below the minimum operating limit.	Replace the Optima Plus unit with a spare and return it to Honeywell Analytics for service or repair.
W-See Ops Guide Obscured Optics	WARNING: Foreign objects or contaminants are present in the optical path. FAULT: The optical path has become heavily obscured by contaminants or foreign objects.	(1) Remove the weather protection and dust barrier. (2) Clean the optics and remove any foreign objects from the measurement path. See (1) & (2) above.
W-See Ops Guide Neg Gas Reading	WARNING: There is a small negative offset on the unit's zero gas reading. FAULT: There is a significant negative offset on the unit's zero gas reading.	(1) The main cause of negative offsets is moisture / condensation on the optics. Check that the optics are clean and dry. If the units is in an environment where very damp / condensing conditions are prevalent, consider additional protection. (Fitting of Storm Baffle or use of sampling system.)

8. FAULT FINDING

SHC-1 Handheld Text	Description	Remedial Action(s)
W-See Ops Guide Neg Gas Reading		<p>(2) Zero offsets can also be caused by exposing the unit to extreme temperatures. Check log for Temp Lim Exceeded entries.</p> <p>(3) Provided that optics are clean and dry, re-zero unit. (See Section 7.2)</p>
W-See Ops Guide Zero Track Limit	<p>WARNING (ONLY): The smart zero tracking routine has reached it's compensation limit.</p>	<p>Only possible on units with this option enabled (the default setting is 'disabled').</p> <p>(1) Check that optics are clean and dry.</p> <p>(2) Check log to see that unit has not been exposed to extreme temperatures.</p> <p>(3) Re-zero unit.</p>
W-See Ops Guide Signal Quality	<p>FAULT (ONLY): The optical signals being measured inside the unit are too low, noisy or unstable to produce accurate gas readings.</p>	<p>(1) Check that the optics are clean and dry. If this clears the problem, re-zero the unit.</p> <p>(2) Check that there are no foreign objects or substances moving inside the measurement chamber.</p>

8. FAULT FINDING

SHC-1 Handheld Text	Description	Remedial Action(s)
<p>W-See Ops Guide Signal Quality</p>		<p>(3) Check that the unit is not being exposed to excessive vibration or temperatures.</p> <p>(4) Check that the 24V power supply to the unit is relatively stable and free from transients, interruptions and surges.</p> <p>(5) Ensure that the unit is adequately protected from thermal shock. (Rates of change greater than 3 degrees centigrade per minute can cause problems.)</p> <p>(6) Attempt to restart the unit by either switching the power off and on again or selecting the DIAGNOSTIC > SOFTWARE RESET option on the SHC-1.</p> <p>(7) If the above checks / actions do not resolve the problem, the unit has probably developed a hardware fault. Return the unit to Honeywell Analytics for repair.</p>

8. FAULT FINDING

SHC-1 Handheld Text	Description	Remedial Action(s)
W-See Ops Guide Internal Failure	FAULT (ONLY): An internal hardware fault has been diagnosed.	(1) Attempt to restart the unit by switching the power off and on again or selecting the DIAGNOSTIC > SOFTWARE RESET option on the SHC-1. (2) If the problem persists, return the unit to Honeywell Analytics for repair / replacement.
W-Informative Alarm	WARNING (ONLY): The unit is or has detected a gas level that exceeds the alarm threshold.	Provided for establishing whether genuine alarm signals have been generated by the unit. Minimum alarm threshold is 10%.

9. REPLACEMENT OF HAND-HELD INTERROGATOR BATTERY

CAUTION

Only use batteries specified below.
Replace the battery only in a Safe Area.

To replace the battery in the Hand-Held Interrogator SHC-1 proceed as follows:

OLDER NON ATEX VERSION CERT. NO BASEX95C2005
ONLY USE DURACELL MN1604 TYPE 6LR61 OR VARTA
4022,6LR61

LATER ATEX VERSIONS CERT NO. BAS03ATEX0073
ONLY USE DURACELL MN1604 TYPE 6LR61

- (1) Remove the Interrogator from its protective pouch.
- (2) Using a 2.5mm allen hexagonal key, loosen the four screws on the rear cover of the Interrogator.
- (3) Carefully lift the front half of the Interrogator away from the rear cover, ensuring the flexible connector connecting the key pad to the electronics module is not damaged.
- (4) Unclip the old battery and fit the new battery in position.
- (5) Carefully replace the front half of the Interrogator back into the rear cover, ensuring the flexible connector lies flat.
- (6) Using a 2.5mm allen hexagonal key, tighten the four screws on the rear cover of the Interrogator.

10. ORDERING DETAILS

INSTRUMENT	
Certified:	ATEX/SAA
2108N4000	Hydrocarbon calibration, with dust barrier, weather housing, deluge/heat shade, configured as current source output
2108N4001	Ethylene calibration, with dust barrier, weather housing, deluge/heat shade, configured as current source output
2108N4010	Hydrocarbon calibration, with dust barrier, weather housing, deluge/heat shade, configured as current source output including remote gassing cell
2108N4011	Ethylene calibration with dust barrier, weather housing, deluge/heat shade, configured as current source output including remote gassing cell
2108N5000	Hydrocarbon calibration, for use in remote sampling systems complete with flow housing
2108N5001	Ethylene calibration, for use in remote sampling systems complete with flow housing
Certified:	UL
2108N4100	Hydrocarbon calibration, with dust barrier, weather housing, deluge/heat shade, configured as current source output
2108N4101	Ethylene calibration, with dust barrier, weather housing, deluge/heat shade, configured as current source output
2108N4110	Hydrocarbon calibration, with dust barrier, weather housing, deluge/heat shade, configured as current source output including remote gassing cell
2108N4111	Ethylene calibration with dust barrier, weather housing, deluge/heat shade, configured as current source output including remote gassing cell
2108N5100	Hydrocarbon calibration, for use in remote sampling systems, includes flow housing, configured as current source output
2108N5101	Ethylene calibration, for use in remote sampling systems, includes flow housing, configured as current source output
Certified:	CSA
2108N4200	Hydrocarbon calibration, with dust barrier, weather housing, deluge/heat shade, configured as current source output
2108N4201	Ethylene calibration, with dust barrier, weather housing, deluge/heat shade, configured as current source output
2108N4210	Hydrocarbon calibration, with dust barrier, weather housing, deluge/heat shade, configured as current source output including remote gassing cell
2108N4211	Ethylene calibration with dust barrier, weather housing, deluge/heat shade, configured as current source output including remote gassing cell
2108N5200	Hydrocarbon calibration, for use in remote sampling systems, includes flow housing, configured as current source output

10. ORDERING DETAILS

2108N5201	Ethylene calibration, for use in remote sampling systems, includes flow housing, configured as current source output
ACCESSORIES	
2108B0259	Dust Barrier
2108B0276	Weather housing labyrinth
2108B0280	Storm Baffle (ATEX)
2108B0282	Optima Plus Flow Housing
2108D0258	Optima Plus Gassing Cover (used for calibration)
2108B0272	Optima Plus Calibration Cap
2108D0275	Optima Plus Deluge / Heat Shade
04200-A-1201	Optima 4-20mA To Bridge Converter
2104B2381	DX100i XP Termination Unit UL with IS barrier
2104B2382	DX100M XP Termination Unit UL with MODBUS capability
2104B6211	DVC100i MK2 Termination Unit ATEX
2104B6212	DVC100M MK2 Termination Unit ATEX with MODBUS capability
2104B6205	DVC100i Termination Unit SAA
2104B6206	DVC100M Termination Unit SAA with MODBUS capability
04230-A-1001	Hand Held Interrogator ATEX Certified (4V0 software) for Optima, Optima Plus and Excel
2104B2351	Hand Held Interrogator UL Certified (4V0 software) for Optima, Optima Plus and Excel
2104B2354	Hand Held Interrogator CSA Certified (4V1 software) for Optima, Optima Plus and Excel
04230-A-1010	Hand Held Interrogator SAA Certified (4V0 software) for Optima, Optima Plus and Excel
2108B1455	Hand Held EEPROM upgrade (4V0)
04230-A-1025	SHC protection device module and lead
2104B6250	SHC Calibrator Connector System 10m
2441-0022	6 wire Junction Box (UL certified)
00780-A-0100	Term Hsg-Bartec DE1155 With Continuity Plate 1x25mm- 3x20mm Entries (ATEX certified)

10. ORDERING DETAILS

04200-A-1040	Optima Junction Box Adaptor Plate
2442-0016	Universal Duct Mounting Kit
2104B0349	Optima Duct Mounting Kit MK2
04200-N-9002	Fit 2 Cable Glands To Optima DVC100
2441-0001	Stainless Steel Tag, 3.0" x 0.5", #10 (M5) screw
2992-0038	Adapter M25 female to 3/4 NPT male Stainless Steel
157-001-074	Adapter 3/4 NPT female to M25 male Stainless Steel
157-001-075	Adapter M20 male to 3/4 NPT female Stainless Steel
SPARES	
2108B2001	Hydrocarbon Optima Plus, ATEX/SAA
2108B2003	Ethylene Optima Plus, ATEX/SAA
2108B2101	Hydrocarbon Optima Plus, UL
2108B2103	Ethylene Optima Plus, UL
2108B2201	Hydrocarbon Optima Plus, CSA
2108B2203	Ethylene Optima Plus, CSA
MANUALS (HARD COPY)	
Note: Electronic copies of the manuals are supplied on CD with each instrument	
2108M0509	Optima Plus Installation Guide (English)
2108M0501	Optima Plus Operating Instructions (English)
2104M0701	DX100 Series Termination Units Technical Handbook (English)
2104M0408	DVC100(I) MK2 Termination Unit Quick Start Guide (English)
2104M0409	DVC100(M) MK2 Termination Unit Quick Start Guide Guide (English)
2104M0412	DVC100(I) SAA Termination Unit Quick Start Guide (English)
2104M0413	DVC100(M) SAA Termination Unit Quick Start Guide Guide (English)

11. SPECIFICATION

11.1 SEARCHPOINT OPTIMA PLUS SPECIFICATION

MEASUREMENT RANGE: 0 to 100% LEL

DETECTABLE GASES

GAS TABLES FOR USE WITH THE HYDROCARBON VERSION OF OPTIMA PLUS

CALIBRATED AGAINST EN50054 LEL VALUES					
	Table No.	Table Name	Full Scale	LEL (%V/V)	EXAM Approved
Standard Gases	D3001	Methane	100%LEL	5	Y
	D3002	Ethane	100%LEL	3	
	D3004	Propane	100%LEL	2	Y
	D3005	Butane	100%LEL	1.5	Y
Special Gases	D3006	Propene	100%LEL	2	
	D3012	Acetone	100%LEL	2.15	
	D3018	Butan-1-ol	100%LEL	1.4	
	D3020	Butyl acetate	100%LEL	1.2	
	D3022	Butanone	100%LEL	1.8	
	D3024	Cyclohexane	100%LEL	1.2	
	D3026	Cyclohexanone	100%LEL	1.3	
	D3028	Ethanol	100%LEL	3.3	
	D3030	Ethyl acetate	100%LEL	2.1	
	D3032	Heptane	100%LEL	1.1	
	D3034	Hexane	100%LEL	1.2	
	D3040	Methanol	100%LEL	5.5	
	D3042	Toluene	100%LEL	1.2	
	D3044	o-Xylene	100%LEL	1	
	D3048	Diethyl ether	100%LEL	1.7	
	D3054	p-Xylene	100%LEL	1	
	D3056	Pentanes	100%LEL	1.4	
	D3059	Dimethyl ether	100%LEL	3	
	D3064	N,N-Dimethyl formamide (DMF)	100%LEL	2.2	
D3073	Propane	100%LEL	2.0	Y	

11. SPECIFICATION

CALIBRATED AGAINST EN61779 LEL VALUES					
	Table No.	Table Name	Full Scale	LEL (%V/V)	EXAM Approved
Standard Gases	D3170	Methane	100%LEL	4.4	Y
	D3171	Ethane	100%LEL	2.5	
	D3172	Propane	100%LEL	1.7	Y
	D3173	Butane	100%LEL	1.4	Y
Special Gases	D3013	Acetone	100%LEL	2.5	Y
	D3019	Butan-1-ol	100%LEL	1.7	Y
	D3021	Butyl acetate	100%LEL	1.3	Y
	D3023	Butanone	100%LEL	1.8	Y
	D3025	Cyclohexane	100%LEL	1.2	
	D3027	Cyclohexanone	100%LEL	1	Y
	D3029	Ethanol	100%LEL	3.1	Y
	D3031	Ethyl acetate	100%LEL	2.2	Y
	D3033	Heptane	100%LEL	1.1	Y
	D3035	Hexane	100%LEL	1	Y
	D3037	Propan-2-ol	100%LEL	2	Y
	D3039	Propyl acetate	100%LEL	1.7	
	D3041	Methanol	100%LEL	5.5	Y
	D3043	Toluene	100%LEL	1.1	Y
	D3045	o-Xylene	100%LEL	1	Y
	D3049	Diethyl ether	100%LEL	1.7	
	D3055	p-Xylene	100%LEL	1	Y
	D3056	Pentanes	100%LEL	1.4	
	D3062	Octane	100%LEL	0.8	
	D3070	Isobutane	100%LEL	1.3	
	D3078	i-Propyl Acetate	100%LEL	1.8	
D3084	Chloroethane	100%LEL	3.6		
D3085	Propan-1-ol	100%LEL	2.2		
D3090	1,2-Dichloroethane	100%LEL	6.2		
D3098	Dimethyl ether	100%LEL	2.7	Y	
D3174	Propene	100%LEL	2	Y	

11. SPECIFICATION

ADDITIONAL RANGES OFFERED					
	Table No.	Table Name	Full Scale	LEL (%V/V)	EXAM Approved
Special Gases	D3017	Hexamethytrisiloxane (HMDS)	100%LEL	1.3	
	D3036	Propan-2-ol	100%LEL	2	
	D3038	Propyl acetate	100%LEL	1.8	
	D3047	Benzin 60/95	100%LEL	1	Y
	D3050	Methane V/V	100%V/V	NA	
	D3058	AVTUR JP8	100%LEL	0.8	
	D3060	Decamethyltetrasiloxane (DCMTS)	100%LEL	0.9	
	D3061	Octane	100%LEL	1	
	D3063	Octamethyltetrasiloxane (OMTS)	100%LEL	0.9	
	D3067	JP1	100%LEL	0.6	
	D3068	Methyl isobutyl Ketone (MIBK)	100%LEL	1.4	
	D3069	Isobutane	100%LEL	1.8	
	D3077	1-Pentene	100%LEL	1.4	
	D3081	1-Octene	100%LEL	0.7	
	D3083	1-Hexene	100%LEL	1.2	
	D3087	Methane 100k	100k ppm	NA	
	D3088	Ethylene 100k	100k ppm	NA	
	D3089	Propane 100k	100k ppm	NA	
	D3092	Propene 50k	50k ppm	NA	
	D3093	1-Methoxy-2-Propanol	100%LEL	1.8	Y
	D3094	3-Ethoxy-1-Propanol	100%LEL	1.3	
	D3095	Benzin 80/110	100%LEL	0.9	Y
	D3096	Propane 10k	10k ppm	NA	Y
	D3097	Propane 5k	5k ppm	NA	Y
	D3100	Propane 400k	400k ppm	NA	
	D3101	Propylene Glycol Methyl Ether Acet	100%LEL	1.3	
	D3102	Propane 600k	600k ppm	NA	
	D3105	Propane 20k	20k ppm	NA	
	D3107	Butane 18k	18k ppm	NA	
	D3108	Methyl amyl Ketone (MIAK)	100%LEL	1.3	
	D3111	1-Ethoxy-2-Propanol	100%LEL	1.3	Y
	D3150	Band A	100%LEL	NA	
	D3151	Band B	100%LEL	NA	
D3152	Band C	100%LEL	NA		
D3153	Band D	100%LEL	NA		
D3175	Propane 5k	5k ppm	NA	Y	

11. SPECIFICATION

GAS TABLES FOR USE WITH THE ETHYLENE VERSION OF OPTIMA PLUS

CALIBRATED AGAINST EN50054 LEL VALUES					
	Table No.	Table Name	Full Scale	LEL (%V/V)	EXAM Approved
Standard Gases	D3225	Ethylene	100%LEL	2.7	Y
Special Gases	D3227	Benzene	100%LEL	1.2	
	D3228	Styrene	100%LEL	1.1	
	D3229	Buta-1,3-diene	100%LEL	1.4	

CALIBRATED AGAINST EN61779 LEL VALUES					
	Table No.	Table Name	Full Scale	LEL (%V/V)	EXAM Approved
Standard Gases	D3240	Ethylene	100%LEL	2.3	Y
Special Gases	D3227	Benzene	100%LEL	1.2	
	D3228	Styrene	100%LEL	1.1	
	D3229	Buta-1,3-diene	100%LEL	1.4	

Note: For other gases, solvents and vapours, contact Honeywell Analytics.

ACCURACY

OPTIMA PLUS (HC):

Baseline < +/- 1% LEL,
50% FSD < +/- 2% LEL

OPTIMA PLUS (ET):

Baseline < +/- 2% LEL,
50% FSD < +/- 3% LEL

REPEATABILITY:

< +/- 2% LEL @ 50% FSD

LINEARITY:

< +/- 5% FSD

RESPONSE TIME:

T50 < 4.5 seconds,
T90 < 6.5 seconds
(For methane, weather protection fitted.)
T50 < 3 seconds, T90
< 5 seconds (Raw response.)

11. SPECIFICATION

OPERATIONAL AND CERTIFIED

TEMPERATURE RANGE: -40°C to +65°C

DRIFT OVER TIME OR

TEMPERATURE RANGE: Baseline < +/- 2% LEL,
50% FSD < +/- 4% LEL

OPERATING HUMIDITY: 0 to 99% RH (non-condensing)

PRESSURE RANGE: 900 to 1100 mbar
(non-compensated)

PRESSURE COEFFICIENT: < 0.1% of reading per mbar

POWER SUPPLY: 18 to 32V (24V nominal)

POWER CONSUMPTION: < 4.5W max

CURRENT DEMAND: < 235mA at 18V
< 190 mA at 24V
< 155mA at 32V

STABILISATION TIME: 1 hour, nominal.

OUTPUTS

ANALOGUE: 4-20mA, non-isolated, current
source or sink. (Default
configuration is current source.)

**MAXIMUM 4-20mA
LOOP RESISTANCE:** 600 Ohms.

DIGITAL: RS485 (Two way, point to point.)

11. SPECIFICATION

OUTPUT SIGNALS:

MEASURING RANGE: (0-100% FSD)	4-20mA
INHIBIT:	1 to 3mA (Default 2mA)
WARNING:	0 to 6mA (Default 3mA*)
FAULT:	0mA
OVER-RANGE:	20 to 21mA (Default 21mA)

CERTIFICATION

APPROVALS:

ATEX:	BAS99ATEX2259X II 2GD EEx d IIC T100°C (T _{amb} -40°C to +55°C) T135°C (T _{amb} -40°C to +65°C)
UL:	Class 1, Div 1, Groups B,C and D. -40°C to +65°C

PERFORMANCE

APPROVALS:	EN61779 EXAM, BVS 03 ATEX G 016 X. See DETECTABLE GASES (section 11.1) for table of approved gases. Approval only valid for 4-20mA output
-------------------	--

EMC COMPLIANCE:	EN50270:1999
------------------------	--------------

ENVIRONMENTAL PROTECTION:

IP 66 / 67

VIBRATION:

10 Hz to 30 Hz, 1,0 mm total
excursion; 31 Hz to 150 Hz, 2 g
acceleration peak.
EN 61779-1:2000 section
4.4.13.2.2.

*Note for ATEX compliance the warning value should not be set between 3 and 5mA

11. SPECIFICATION

DIMENSIONS:

Length: 165mm
Diameter: 73mm

WEIGHT:

1.6kg.

MATERIAL:

316 stainless steel.

11. SPECIFICATION

11.2 CROSS INTERFERENCE TO OTHER GASES AND VAPOURS

Searchpoint Optima is despatched pre-calibrated and ready for installation. The signal output configuration, gas and range for which the unit is calibrated are indicated on a label attached to the main housing.

THE FOLLOWING IS ONLY APPLICABLE WHEN DETECTING HYDROCARBONS:

A Searchpoint Optima Plus Unit calibrated for a particular hydrocarbon will have a response to most other hydrocarbon gases. The cross-sensitivity figures below are approximate and are for guidance only:

Concentration v/v:

2.5%	methane
0.4%	ethane
0.3%	propane
0.2%	butane
0.3%	pentane
0.3%	hexane
0.3%	heptane
0.3%	octane
0.8%	propylene
2.7%	ethylene



Approximate amount of gas required to give an output equal to 50% LEL methane, on Searchpoint Optima calibrated for 100% LEL (fsd) methane.

11. SPECIFICATION

11.3 HAND-HELD INTERROGATOR SHC-1 SPECIFICATION

CERTIFICATION:	BASEEFA 03 ATEX 0073 II 2G EEx ia IIC T4 T _{amb} : -40°C to +40°C
OPERATING TEMPERATURE RANGE:	0°C to +40°C.
STORAGE TEMPERATURE RANGE:	-10°C to +40°C.
OPERATING HUMIDITY:	0 to 99% RH.
DIMENSIONS:	Long: 190mm. Depth: 40mm. Width: 80mm.
WEIGHT:	0.5kg.
MATERIAL:	Stainless Steel ANSI 316.

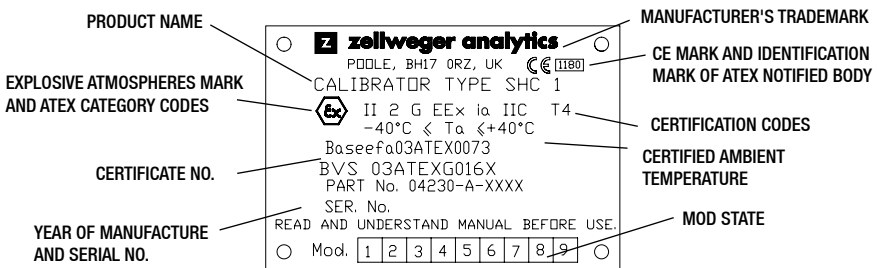

11. SPECIFICATION

11.4 SHC PROTECTION DEVICE



WARNING

Not Certified for use in hazardous areas.

OPERATING

TEMPERATURE RANGE: -40°C to +65°C.

OPERATING HUMIDITY: 0 to 99% RH.

DIMENSIONS:

Lead Length: Long: 670mm

Box Dimensions: Long: 78mm.
Depth: 39mm.
Width: 59mm.

WEIGHT: 0.2kg.

MATERIAL: High Impact ABS.

11. SPECIFICATION

11.5 TERMINATION UNIT DVC100 SPECIFICATION

CERTIFICATION:	ATEX II 2G EEx e m ia IIC (I and M versions)
OPERATING TEMPERATURE:	-40°C to +65°C.
INGRESS PROTECTION:	IP67 to EN 60529:1992
STORAGE TEMPERATURE:	-10°C to +40°C).
OPERATING HUMIDITY:	0 to 99% RH.
DIMENSIONS:	W160 x W160 x D94mm (6 ¼ x 6 ¼ x 3 ¾ inches)
WEIGHT:	2.1kg.
MATERIAL:	DMC reinforced polyester.
EMC COMPLIANCE:	EN 50270:1999 (ATEX approved I and M versions)

Refer to individual manuals for detailed specification.

11. SPECIFICATION

11.6 DX TERMINATION UNITS SPECIFICATION

CERTIFICATION:	UL and CSA CLASS I, Div 1 GROUPS B, C, D.
OPERATING TEMPERATURE:	UL: -25°C to +40°C (-40°F to +104°F) CSA: -55°C to +40°C (-67°F to +104°F)
INGRESS PROTECTION:	IP66 to EN 60529:1992
STORAGE TEMPERATURE:	-10°C to +40°C (14°F to +104°F)
OPERATING HUMIDITY:	0 TO 99% RH
DIMENSIONS:	W212 x H152.4 x D117.5mm (8.35 x 6 x 4.625 inches)
WEIGHT:	2.5kg (5lbs 8oz.)
MATERIAL:	Aluminum

Refer to individual manuals for detailed specification.

12. CERTIFICATION DETAILS

ATEX

CERTIFICATION LABEL DETAILS

An explanation of the information shown on the equipment certification label is shown below:

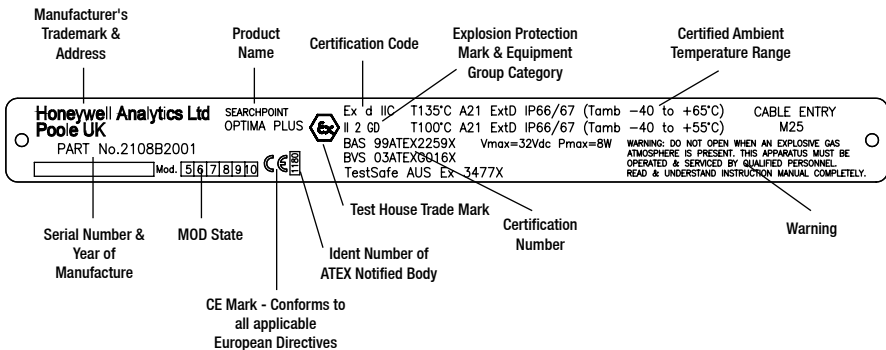

Special conditions for safe use according to BAS99ATEX2259X

The following special properties have to be considered at operation of the device:

- The integral supply cables must be mechanically protected and terminated in suitable terminal or junction facility.
- For replacement purposes the cover fixing screws shall be grade A4-80 minimum.

12. CERTIFICATION DETAILS

Special conditions for safe use according to BVS 03 ATEX G 016 X

The following special properties have to be considered at operation of the device:

- When interconnected with a control unit the specifications of the interface shall be observed. It shall be ensured that the control unit is able to interpret the status signals of the device below 4mA and above 20mA correctly.
- The parameter “warning” shall not be set to values between 3mA and 5mA.
- The advices in the instruction manual concerning the tolerable exposure to vibrations and the specified range of ambient pressure at operation shall be observed.

12. CERTIFICATION DETAILS

ATEX

Searchpoint Optima Plus

II 2GD ATEX
EEx d IIC T4.
-40°C to +65°C
+T5 -40°C to +55°C
V max - 32V

DVC100 MK2 (I) and (M)

EEx e m ia IIC T5
EEx d IIC T4.
-40°C to +65°C
V max - 50V
I max - 5A
Cable Gland M20/M25
Sensor Entry up to 40.65mm diameter

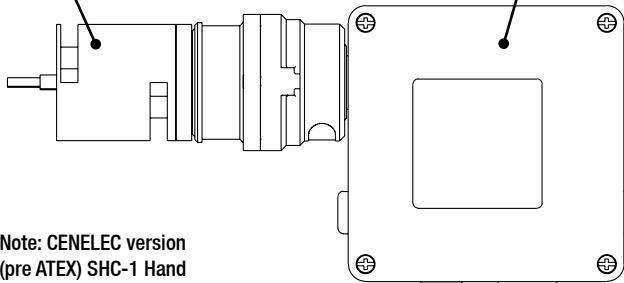

Note: CENELEC version
(pre ATEX) SHC-1 Hand
Held Interrogator can be
used with the CENELEC
Termination Unit.

IS Cable
Length 15m Maximum



Hand Held Interrogator SHC-1
ATEX Version
II 2G EEx ia IIC T4
-40°C to +40°C

Standard Configuration

12. CERTIFICATION DETAILS

ATEX

Searchpoint Optima Plus
II 2GD ATEX
EEx d IIC T4.
-40°C to +65°C
+T5 -40°C to +55°C
V max - 32V

DVC100 MK2 (I) and (M)
EEx e m ia IIC T5
-40°C to +65°C
V max - 50V
I max - 5A
Cable Gland M20/M25
Sensor Entry up to 40.65mm diameter

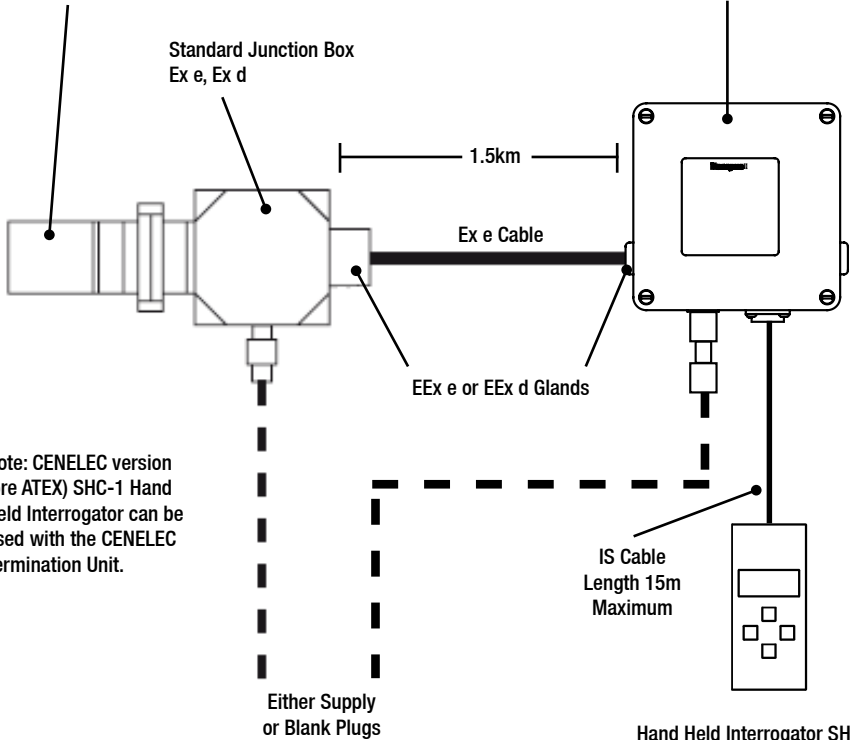

Note: CENELEC version
(pre ATEX) SHC-1 Hand
Held Interrogator can be
used with the CENELEC
Termination Unit.

Hand Held Interrogator SHC-1
ATEX Version
II 2G EEx ia IIC T4
-40°C to +40°C

Alternative Configuration

12. CERTIFICATION DETAILS

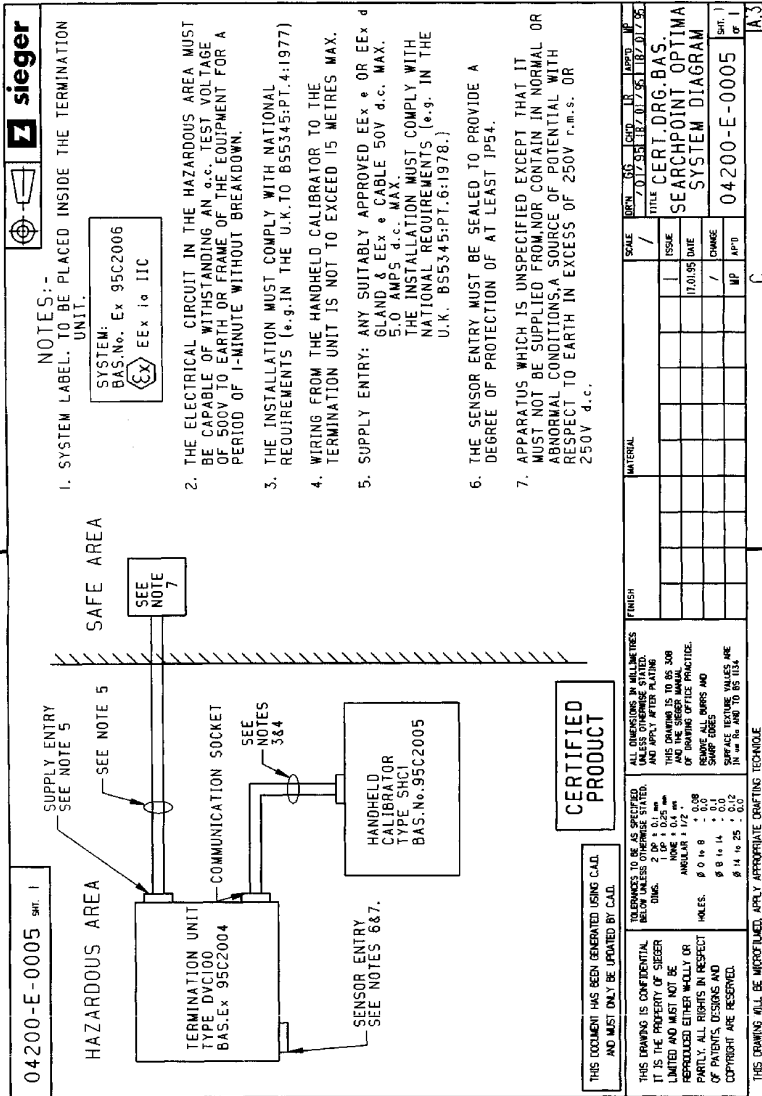

NOTE: ATEX Version of SHC1 Certificate no. Baseefa 03ATEX0073, may be used in place of SHC1 Certificate BAS no. 95C2005 in above diagram. ATEX termination units 03ATEX0261 and 03ATEX0287 may be used in place of termination unit BAS.EX 95C2004 in above diagram.

12. CERTIFICATION DETAILS

UL

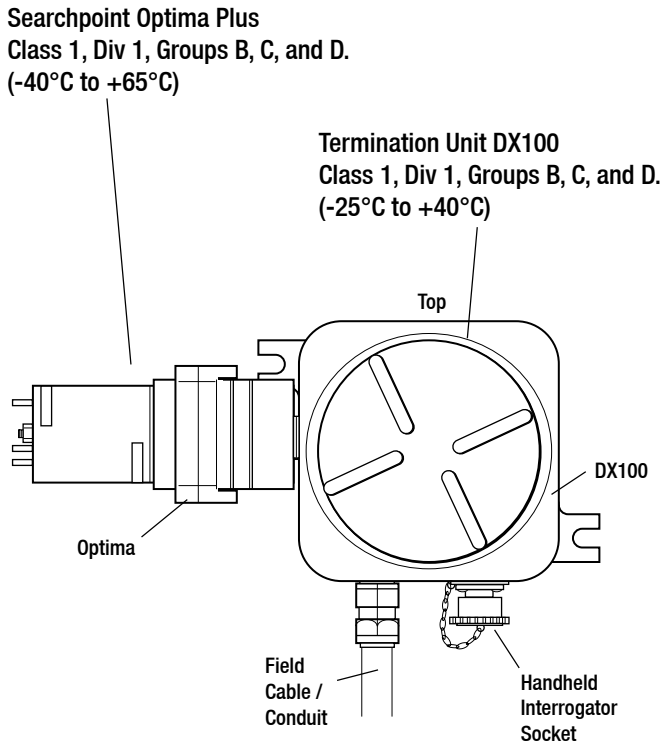

13. WARRANTY

For warranty information, consult the latest issue of WA100 - General Statement of Limited Warranty

NOTES

NOTES



Thank you for reading this data sheet.

For pricing or for further information, please contact us at our UK Office, using the details below.



UK Office

Keison Products,

P.O. Box 2124, Chelmsford, Essex, CM1 3UP, England.

Tel: +44 (0)330 088 0560

Fax: +44 (0)1245 808399

Email: sales@keison.co.uk

Please note - Product designs and specifications are subject to change without notice. The user is responsible for determining the suitability of this product.