



MC227 & MC228X1 CONTROLLER

INSTRUCTION BOOK

Please take your time to read this Instructions book in order to understand the safe and correct use of your new Bibby Scientific product.

It is recommended the Responsible Body for use of this equipment reads this Instruction book and ensures the user(s) are suitably trained in its operation.

CONTENTS

Section 1	Introduction	Page 3
Section 2	Symbols and using this Instruction book	Page 4
Section 3	Safety Information.	Page 5
Section 4	Unpacking and contents	Page 7
Section 5	Installation	Page 8
Section 6	Environmental Protection.	Page 9
Section 7	Product Operation.	Page 10
Section 8	Technical Specification.	Page 12
Section 9	Maintenance	Page 13
Section 10	Customer Support	Page 15
Section 11	Spares and Accessories	Page 16
Section 12	Notes	Page 18
Section 13	EC declaration of Conformity	Page 20
Appendix A	Decontamination Certificate.	Page 17

© The copyright of this instruction book is the property of Bibby Scientific Limited. This instruction book is supplied by Bibby Scientific Limited on the express understanding that it is to be used solely for the purpose for which it is supplied. It may not be copied, used or disclosed to others in whole or part for any purpose except as authorised in writing by Bibby Scientific Limited. Bibby Scientific Limited reserves the right to alter, change or modify this document without prior notification.

In the interest of continued development Bibby Scientific Limited reserve the right to alter or modify the design and /or assembly process of their products without prior notification.

This product is manufactured in Great Britian by Electrothermal, part of the Bibby Scientific Group of companies.

Note: All illustrations in this document are for reference only.

1. INTRODUCTION:

- 1.1. MC227 is a 230V~AC controller. The MC228x1 is a controller 115V~AC.
- 1.2. This series of Power controllers have been designed to regulate the power input to laboratory heating equipment. These controllers can be mounted on a standard ½" (12mm) dia scaffold or retort stand, they can also be wall mounted using mounting bracket or stand directly on the bench.

2. SYMBOLS AND USING THIS INSTRUCTION BOOK.

2.1. Throughout this Instruction book the following symbols are shown to identify conditions which pose a hazard to the user, or to identify actions that should be observed. These symbols are also shown on the product, or its packaging. When a symbol is shown next to a paragraph or statement it is recommended the user takes particular note of that instruction in order to prevent damage to the equipment or to prevent injury to one's self or other people.

The Responsible Body and the Operator should read and be familiar with this Instruction book in order to preserve the protection afforded by the equipment.

To prevent injury or equipment damage it is the manufacturer's recommendation that all persons using this equipment are suitably trained before use.

2.2. Symbols Defined.



Caution, risk of danger. See note or adjacent symbol.



Protective conductor terminal to be earthed.
(Do not loosen or disconnect).



Caution / risk of electric shock.



Recyclable Packing Material.



Do not dispose of product in normal domestic waste.



Bio Chemical Hazard. Caution required. Will require decontamination.

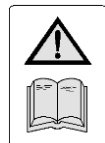

Refer to instructions book.

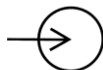

Input mains terminal.



Output mains terminal.

3. SAFETY INFORMATION.

This product has been designed for safe operation when used as detailed in accordance with the manufactures instructions.

NOTE: Failure to use this equipment in accordance with the manufactures operating instructions may compromise your basic safety protection afforded by the equipment and may invalidate the warranty / guarantee. The warranty / guarantee does not cover damaged caused by faulty installation or misuse of the equipment.

3.1. Prevention of Fire and Electric shock.



To prevent a risk of fire or electric shock, **DO NOT** open your product case without authorisation. Only qualified Service personnel should attempt to repair this Controller.



Replace fuses only with the type as listed in section, Parts and Accessories and Technical Specifications. (See fuse type and rating).



Ensure the Mains Power Supply conforms to rating found on the data plate located on the base of this product.



Never Operate this equipment with out connection to earth / ground. Ensure the mains supply voltage is correctly earthed / grounded in accordance with current area legislation.



Do not install or remove any heating apparatus from the controller whilst power is applied.

3.2. General safe Operating Practice.



Always follow good laboratory practice when using this Equipment. Give due recognition to your company's safety and legislative health & safety procedures and all associated legislation applicable to your areas of operation. Check laboratory procedures for substances being heated and ensure all hazards (e.g. explosion, implosion or the release of toxic or flammable gases) that might arise have been suitably addressed before proceeding. When heating certain substances the liberation of hazardous gases may require the use of a fume cupboard or other means of extraction.



Ensure equipment is used on a clean, dry, non-combustible, solid work surface with at least 300mm suitable clearance all around from other equipment.



Do not position the product so that it is difficult to disconnect from the mains supply.



Do not immerse the controller in water or fluids.



Do not spill substances onto this unit. If spillage does occur, disconnect unit from mains supply and follow instructions as detailed in Section 'Maintenance'.



To prevent electronic overheat and potential fire **Do not** cover this product when connected to the mains power supply.



It is **not** recommended to leave any heating apparatus unattended during operation.



Only use Original Equipment manufacture's spares and accessories. Ref Section 10.



The equipment is not spark, flame or explosion proof and has not been designed for use in hazardous areas in terms of BSEN 60079-14:1997. Keep flammable, low flash point substances away from heating apparatus.



Do not operate or handle any part of this product with wet hands.



Keep the Mains Plug and Lead set cable away from the heating apparatus being controlled.



Refer to Instructions book for the resistive load of equipment to ensure controller is suitable for application. (See sub-section 8.1)



Always observe the Manufactures operating and safety instructions for the equipment to be connected to the controller.

NOTE: *if this product is not used in accordance with the Manufacturers Instructions then the basic safety protection afforded by the equipment may not be preserved and the guarantee invalidated.*

4. UNPACKING AND CONTENTS.

- 4.1. Please check the contents of your carton against the diagram.
(Please note MC227 & MC228X1x1 has a hard wired input).

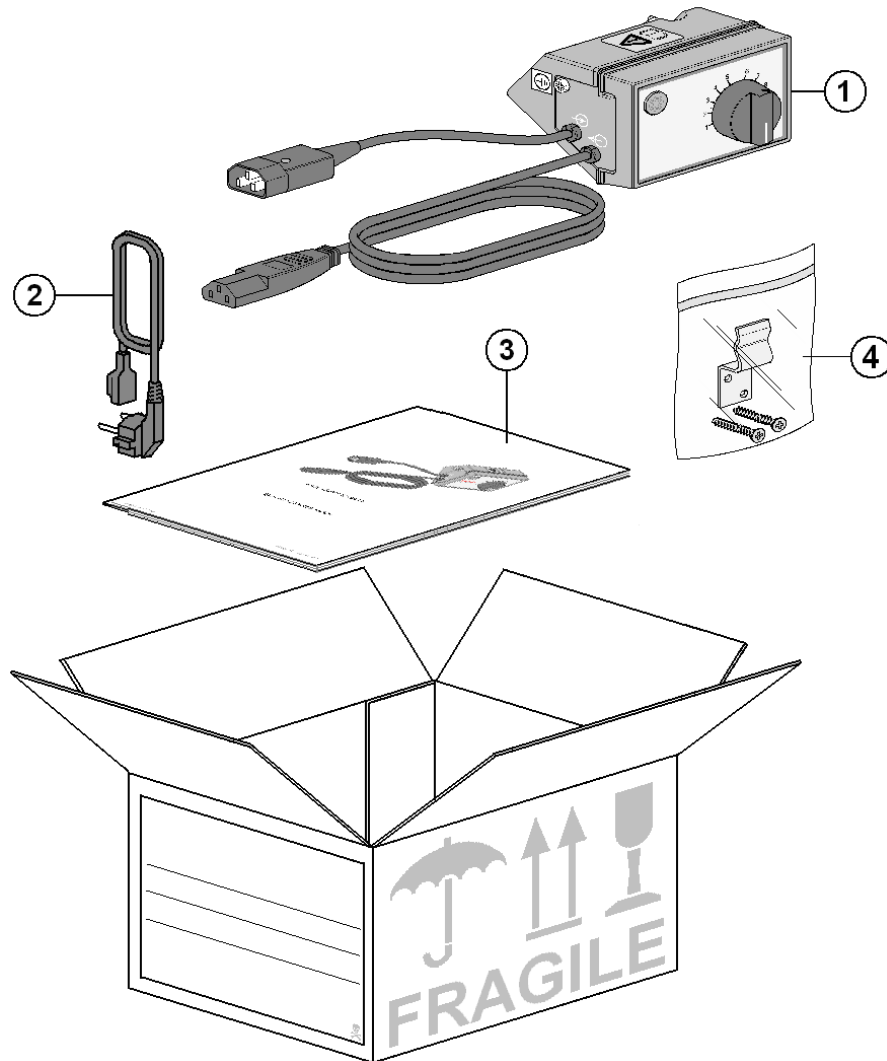

Contents.

Item	Description	Qty
1	MC227 & MC228X1 Control unit	1
2	Moulded mains cord and plug set. (Input) <i>(May be different to illustration).</i>	A/R
3	Instructions book (this document).	1
4	Wall fixing Bkt and screws x 2 – per bag.	1

<p>or future reference please record your products Serial and Model Numbers.</p>	<p>Serial Number</p>	<p>Model Number</p>
--	-----------------------------	----------------------------

5. INSTALLATION

5.1. Electrical safety and installation.

5.2. This equipment is designed to safe under the following conditions:-

- Indoor use.
- Altitude up to 2000 meters.
- Temperatures between 5°C and 40°C.
- Maximum relative humidity 80% for temperatures up to 31°C decreasing linearly to 50% relative humidity at 40°C.
- Mains supply voltage fluctuations up to $\pm 10\%$ of the nominal voltage.
- Transient overvoltage's typically present on the mains supply (Overvoltage Category II)
- Applicable rated pollution degree 2.

5.3.  This equipment must be earthed / grounded to a fixed earth / grounded mains socket outlet. The mains supply is to be earthed / grounded in accordance with current legislation.

5.4. Ensure only the correct rated mains input fuses are fitted. (Where applicable ensure the correct mains cable fuse if fitted). See Technical Information Section 8 of this Instruction book.

5.5. Check the voltage on the product data label of this unit. Ensure the rating conforms to your local supply. If an 115V product is used in a 230V supply area, then a 230/115V transformer must be installed between the 230V mains supply and the product, by a competent electrician.

Only connect controller to resistive loads. Refer to sub-section 8.1.

5.6. It is recommended this unit be connected to a mains supply source which incorporates an RCD or GFCI device.

The unit is supplied with a moulded mains cord and plug set wired as follows:-

	Green / Yellow	or	Green	=	Earth / Ground
	Blue	or	White	=	Neutral
	Brown	or	Black	=	Live / line hot.

5.7. If the controller is to be used on a retort rod, make sure it isn't positioned over any heating apparatus.

6. ENVIRONMENTAL PROTECTION

6.1. Maximum consideration has been given to environmental issues within the design and manufacturing process without compromising end product performance and value.



6.2. Packaging materials have been selected such that they may be sorted for recycling.



6.3. At the end of your product and accessories life, it must not be discarded as domestic waste. Ref: EU Directive 2002/96/EC on Waste Electrical and Electronic Equipment Directive (WEEE). Please contact your distributor / supplier for further information. For end users outside of the EU consult applicable regulations.

6.4. This product should only be dismantled for recycling by an authorised recycling company.



This product and accessories must be accompanied by a completed Decontamination Certificate prior to any disposal. Copies of the Certificate are available from your distributor of Bibby Scientific products, or you may copy and enlarge from 'Appendix A' of this instruction book.

Bibby Scientific's Electrothermal branded product range is registered with the Environment Agency under the name of as Electrothermal Engineering Limited as being a producer of WEEE (Waste Electronic and Electrical Equipment) through b2b Compliance, an authorised waste collection compliance scheme.

7. PRODUCT OPERATION.

7.1. The illustrations below show detailed layout of the MC227 & MC228X1 control unit.

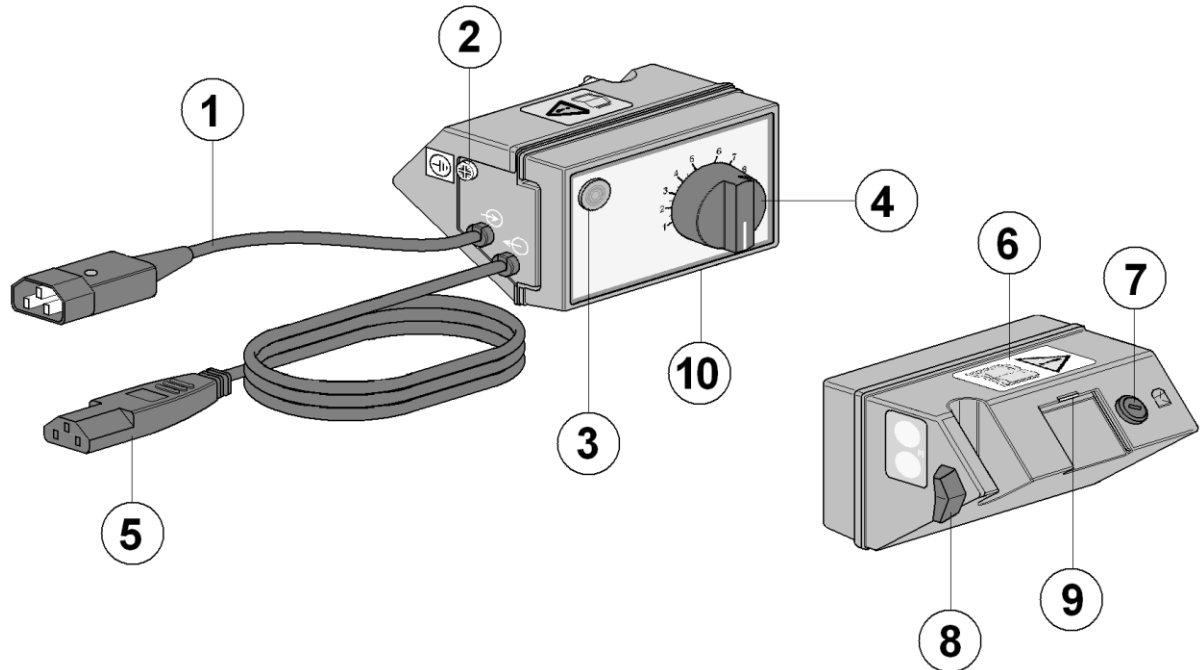

230V illustration

- 1 Mains Input socket.
- 2 Earth continuity test point
- 3 Controlled appliance heaters on neon lamp. (*Amber*).
- 4 Regulator control knob.
- 5 Mains output – connection to appliance
- 6 Refer to instructions book.
- 7 Fuse holder (*See section 8 & 11 for further information*).
- 8 Rod support clamp.
- 9 Support clip.
- 10 Dataplate label. (*See for correct voltage type*).

Check the Dataplate label and ensure your mains electrical supply voltage is compatible with this product.

7.2. Connect the IEC output plug from the controller to your heating apparatus product as illustrated.

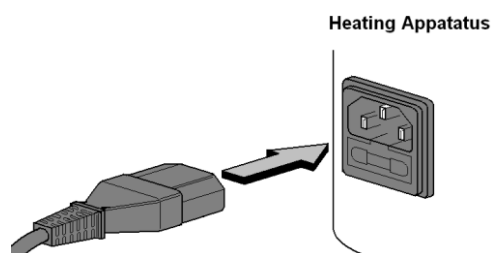

The MC227 & MC228X1 controllers is can be used with the following Electrothermal products:

- EM, EMA, EMV and EMX Series Electromantles
- CMU, CMUT, CMUA, CMUV Series Electromantles

7.3. Connect to the mains electricity supply.

7.4. Switch the controller on by turning the regulator control knob clockwise to increase power. The amber neon lamp on the controller will pulsate to show that power is being supplied to the mantel, heating tape or cord etc. The frequency of the pulse will increase as the regulator control knob setting is increased. At maximum setting the amber neon will be continually illuminated.

7.5. When your process is complete, switch off the controller and disconnect it from the mains electricity supply.

7.6.  **For safe operating practice always refer to the Instruction book of the equipment being used.**

8. TECHNICAL SPECIFICATION.

8.1. Specifications.

Mains supply voltage	230V~AC 50/60 Hz
Mains supply voltage MC227 & MC228x1	115V~AC 50/60 Hz
Maximum coupled power consumption	MC227 230V – 2.3kW MC228x1 115V – 1.1kW
Controller power consumption	<1 Watt.
Fuse rating at 230V	10A 32x6mm Quick Blow
Fuse rating at 115V	10A 32x6mm Quick Blow
Mains cord and moulded IEC plug and lead set cable (UK) 13A BS1362 AZ9165	3 core earthed / ground. 2 meters long Moulded IEC plug and Lead set – supply cord H05 V V-F- Replace only with equivalent cable.
Mains cord and moulded IEC plug and lead set cable (Europe) AZ6747	3 core earthed / ground. 2 meters long Moulded IEC plug and Lead set – supply cord H05 V V-F- Replace only with equivalent cable.
Mains cord and moulded IEC plug and lead set cable (USA) AZ6746	3 core earthed / ground. 2 meters long Moulded IEC plug and Lead set – supply cord SJT VW 1- 105° Replace only with equivalent cable.
Mains cord and moulded IEC plug and lead set cable (Australia) M7079	3 core earthed / ground. 2 meters long Moulded IEC plug and Lead set – supply cord H05 V V-F Replace only with equivalent cable.
Lead set plug fuse (UK – only)	13A BS1362

The Ingress Protection rating for this product is classified as IPX 0.



Do not allow this product to come into contact with liquid.

8.2. Dimensions & weight (unpacked).

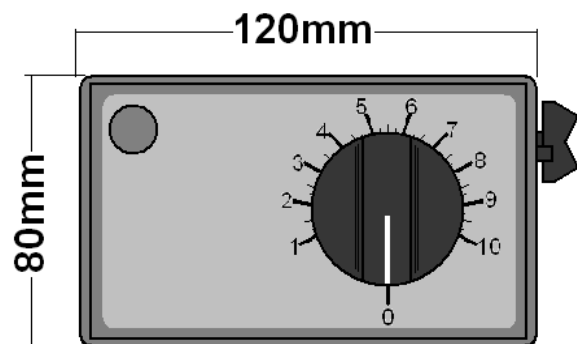
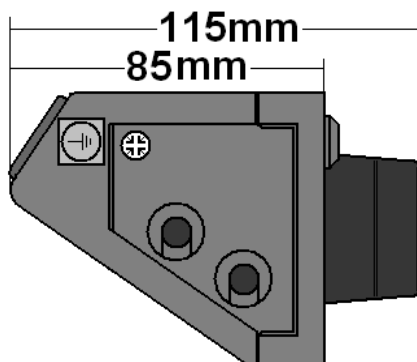

Weight 0.82 Kg

9. MAINTENANCE.

9.1. General information.

 Unplug the unit from the mains voltage supply and allow it to cool before undertaking any maintenance tasks.

 Maintenance should only be carried out under the direction of the Responsible Body, by a competent electrician. Failure to do so may result in damage to the product and in extreme cases be a danger to the end user.

With proper care in operation this equipment has been designed to give many years of reliable service. Contamination or general misuse will reduce the effective life of this product and may cause a hazard.

Maintenance for the unit should include:

- Periodic electrical safety testing (an annual test is recommended as the minimum requirement).
- Regular inspection for damage with particular attention to the mains lead and plug set.
- Routine cleaning of the equipment should be undertaken using a clean cloth.

DO NOT USE SOLVENTS FOR CLEANING ANY PART OF THIS EQUIPMENT.

9.2. Replacing controller fuse.

MC227 & MC228X1X1

① Unscrew the fuse holder cap from the fuse housing and ② remove the fuse. Fit replacement fuse of the correct rate and value (see section 11 – Spares and accessories).

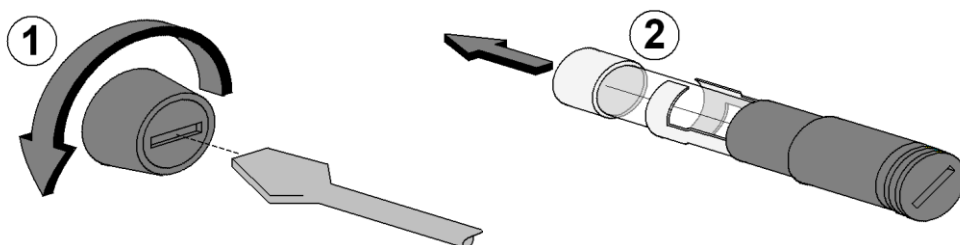

9.3. Spillage and Decontamination.

In the event of spillage switch off and unplug this product from the mains electrical supply. Wipe off all excess liquid from the product and surrounding area using an absorbent soft cloth. Allow sufficient time for any ingressed liquid to evaporate before commencing with use.

If in doubt please consult Customer Support. Refer to section 10.



If the equipment has been exposed to contamination, the Responsible Body is responsible for carrying out appropriate decontamination. If hazardous material has been spilled on or inside the equipment, decontamination should only be undertaken under the control of the Responsible Body with due recognition of possible hazards. Before using any cleaning or decontamination method, the Responsible Body should check with the manufacturer the proposed method will not damage the equipment.

Prior to further use, the Responsible Body shall check the electrical safety of the unit. Only if all safety requirements are met can the unit be used again. The above procedure is intended as a guide. Should spillage occur with a toxic or hazardous fluid then special precautions may be necessary.

Decontamination Certificate.

Note: In the event of this equipment or any part of the unit becoming damaged, or requiring service, the item(s) should be returned to the manufacturer for repair accompanied by a decontamination certificate. **Copies of the Certificate are available from Distributor/Manufacturer. Appendix A of this instructions book may be copied and enlarged.**

At the end of life, this product must be accompanied by a Decontamination Certificate. See section 6.3 and 6.

10. CUSTOMER SUPPORT

For help and support in using this product, please contact Customer Services at the following address.

Bibby Scientific Limited.

Beacon Road,
Stone,
Staffordshire ST15 0SA,
Great Britain.

Tel: +44(0)1785 812121
Fax: +44(0)1785 810405

- General enquiries :
info@bibby-scientific.com
- Order enquiries :
sales@bibby-scientific.com
- Technical support :
electrothermalhelp@bibby-scientific.com
- www.electrothermal.com

For the America's and Canada, contact:

Techne Incorporated, 3 Terri Lane,
Suite 10 Burlington, NJ 08016 USA.

Toll free:800-225-9243Tel: 609-589-2560

Fax: 609-589-2571

Email: labproducts@techneusa.com

Http www.techneusa.com

11.SPARES AND ACCESSORIES.

Order Number	Description.	Qty
Neon (230V) Amber	M5608	1
Neon (115V) Amber	M5620	1
Fuse (230V) F10A	AZ9034	10
Fuse (115V) F10A	AZ9034	10
Energy Regulator (230V)	AZ9127	1
Energy Regulator (115V)	AZ9128	1
Mounting Bracket Kit	AZ6704	1
Mains cord and moulded IEC plug and lead set (UK) 230V ~ AC	AZ9165	1
Mains cord and moulded IEC plug and lead set (USA) 115V ~ AC	AZ6746	1
Mains cord and moulded IEC plug and lead set (Europe) 230V ~ AC	AZ6747	1
Mains cord and moulded IEC plug and lead set (UK) 230V ~ AC	AZ9165	1

APPENDIX 'A'. DECONTAMINATION CERTIFICATE.

<p>Bibby Scientific Limited. Beacon Road, Stone, Staffordshire ST15 0SA. Great Britain Tel: +44(0)1785 812121. Fax: +44(0)1785 810405 E-mail: electrothermalhelp@bibby-scientific.com</p>		
<p><u>DECONTAMINATION CLEARANCE CERTIFICATE</u></p>		
<p>For the Inspection, Repair or Return of Medical, Laboratory or Industrial Equipment.</p>		
<p>Prior to a Service Engineer working on equipment that has been in an environment where substances hazardous to health may have been used, you are requested to provide the following information:</p>		
<p>CUSTOMER DETAILS</p>		
<p>Company:-</p>	<p>Address:-</p>	
<p>Department:-</p>	<p>Post Code:-</p>	
<p>Contact Name:-</p>		
<p>Tel No:-</p>		
<p>Fax No:-</p>		
<p><u>Product Description</u></p>		
<p>Model No:-</p>	<p>Serial No:-</p>	
<p>Has the equipment been exposed to any of the following. Please answer all questions by deleting YES/NO as applicable and by providing details in section 2 below.</p>		
<p>A. Blood, body fluids, Pathological specimens</p>	<p>YES/NO</p>	<p>Provide details if YES</p>
<p>B. Biodegradable material that could become a hazard</p>	<p>YES/NO</p>	<p>Provide details if YES</p>
<p>C. Other biohazard</p>	<p>YES/NO</p>	<p>Provide details if YES</p>
<p>D. Chemical or substances hazardous to health</p>	<p>YES/NO</p>	<p>Provide details if YES</p>
<p>E. Radioactive substances State name(s) and quantities of isotopes and checks made for residual activity</p>	<p>YES/NO</p>	<p>Provide details if YES</p>
<p>F. Other hazards</p>	<p>YES/NO</p>	<p>Provide details if YES</p>
<p>2. Please provide details of any hazard present as indicated above. Include details of names and quantities of agents as appropriate:-</p>		
<p>3. Your method of decontamination (please describe):-</p>		
<p>4. Are there likely to be any areas of residual contamination (please specify)</p>		
<p>I declare that the above information is true and complete to the best of my knowledge and belief.</p>		
<p>Authorised signature:-</p>	<p>Name (please print):-</p>	
<p>Title/Position:-</p>		
<p>For and behalf of:-</p>	<p>Date:-</p>	

12. NOTES.

13. EC DECLARATION OF CONFORMITY.

CE marked products and associated accessories covered by this Instruction book conform to the essential requirements of the following directives:

EMC Directive.

Low Voltage Directive.



Thank you for reading this data sheet.

For pricing or for further information, please contact us at our UK Office, using the details below.



UK Office

Keison Products,

P.O. Box 2124, Chelmsford, Essex, CM1 3UP, England.

Tel: +44 (0)330 088 0560

Fax: +44 (0)1245 808399

Email: sales@keison.co.uk

Please note - Product designs and specifications are subject to change without notice. The user is responsible for determining the suitability of this product.