



(Reaction Block not included).

RS9000 A HEATED, ORBITAL AGITATOR REACTION STATION.

PS83000 (230V). PS83000x1 (115V).

INSTRUCTION BOOK



ATTENTION: 42Kg Product Weight.



The unpacked weight of this equipment is 42Kg. To avoid injury it is recommended that it always be lifted by 2 persons.

Please take your time to read this Instructions book in order to understand the safe and correct use of your new Bibby Scientific product.

It is recommended the responsible Body for the use of this equipment reads this instruction book and ensures the user(s) are suitably trained in its operation.

CONTENTS

Section 1.	Introduction.	Page 3
Section 2.	Symbols used in this Instructions book.	Page 4
Section 3.	Safety Information.	Page 5
Section 4.	Unpack and Contents.	Page 4
Section 5.	Installation.	Page 9
Section 6.	Environmental protection.	Page 10
Section 7.	Production Operation.	Page 11
Section 8.	Technical Specifications.	Page 20
Section 9.	Maintenance	Page 21
Section 10.	Parts and Accessories.	Page 24
Section 11.	Customer Support.	Page 26
Section 12.	Notes.	Page 27
Section 13.	EC Declaration of Conformity	Page 28
Appendix 'A'	Decontamination certificate	Page 25

© The copyright of this instruction book is the property of Bibby Scientific Limited. This instruction book is supplied by Bibby Scientific Limited on the express understanding that it is to be used solely for the purpose for which it is supplied. It may not be copied, used or disclosed to others in whole or part for any purpose except as authorised in writing by Bibby Scientific Limited. Bibby Scientific Limited reserves the right to alter, change or modify this document without prior notification.

In the interest of continued development Bibby Scientific Limited reserve the right to alter or modify the design and /or assembly process of their products without prior notification.

This product is manufactured in Great Britain by Electrothermal, part of the Bibby Scientific Group of companies.

1. INTRODUCTION











- 1.1. Your RS9000 Agitator Reaction Station is flexible and ready for the tough demands of today's modern laboratory. With an 'easy to operate / easy to read, revolutionary CTC panel (Capacitance Touch Control), setting the required temperature and agitation speed takes just moments. The toughened, laminated glass panel is chemical impervious to most acids and solvents through which a clear digital readout displays real-time temperature and agitation data on the high definition LCD. Cool blue illuminated touch key zone areas are visible in both bright and dim lighting conditions and are less harmful to light sensitive chemicals than other illuminations, while an acid etched finish on the glass reduces unwanted glare and reflection. A 'Hot Surface' safety-warning symbol illuminates to warn the user when the agitation plate temperature has reached 50°C ($\pm 4^\circ\text{C}$), and remains operational even when this product is unplugged from the mains power supply.
- 1.2. For stability this product has a solid bronze chassis on which the renowned X – Y gyration system, proven to provide many years of reliable service is mounted. Tapered roller bearings provide smooth running agitation allowing full, accurate control of agitation speed even at low revolutions. Advanced Micro controllers and superior firmware monitor temperature and agitation speed constantly and make the required adjustments as necessary. The direct heat plate accommodates all OEM interchange agitation blocks while the auto park position facility all add up to make this product Reaction Station perhaps the most versatile agitation station on the market.
- 1.3. This product has been designed as a stand-alone Reaction Station or to be incorporated into a robotic system, and may be controlled via a PC where various temperature, agitation speed and time profiles can be set. This product has a very compact rugged profile, allowing most robotic platforms to hold your Reaction Station. RS9000 units are compact and solid but they can be manoeuvred in and out of the workstation or a robotic system enabling you to use this product as an independent Agitation Reaction Station in the morning and part of workstation or robotic system in the afternoon.

2. SYMBOLS USED IN THIS INSTRUCTION BOOK.

2.1. Throughout this Instruction book the following symbols are shown to identify conditions which pose a hazard to the user, or to identify actions that should be observed. These symbols are also shown on the product, or its packaging. When a symbol is shown next to a paragraph or statement it is recommended the user takes particular note of that instruction in order to prevent damage to the equipment or to prevent injury to one's self or other people.

To prevent injury or equipment damage it is the manufacturer's recommendation that all persons using this equipment are suitably trained before use.

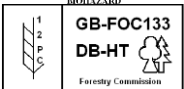
2.2. Symbols Defined.

	Caution, risk of danger. See note or adjacent symbol.
	Protective conductor terminal to be earthed. (Do not loosen or disconnect).
	Caution / risk of electric shock
	Recyclable Packing Material
	Do not dispose of product in normal domestic waste.
	Caution. Hot surface.
	Refer to Instructions book.
	Product Weight Warning.
	Bio Chemical Hazard. Caution required. Will require decontamination.
	Timber Import Insect free.
	Stirring Facility On / Off
	Heating Facility On / Off

3 SAFETY INFORMATION.

This product has been designed for safe operation when used as detailed in accordance with the Manufacture's instructions.

NOTE: Failure to use this equipment in accordance with the manufacture's operating instructions may compromise your basic safety protection afforded by the equipment and may invalidate the warranty / guarantee. The warranty / guarantee does not cover damaged caused by faulty installation or misuse of the equipment.

3.1 Prevention of Fire and Electric Shock



To prevent a risk of fire or electric shock, **DO NOT** open your product case without authorisation. Only qualified Service personnel should attempt to repair this product



Replace fuses only with the type as listed in section, Parts and Accessories and Technical Specifications. (See fuse type and rating)



Ensure the Mains Power Supply conforms to rating found on the data plate located on the back of this Product.



Never Operate this equipment with out connection to earth / ground. Ensure the mains supply voltage is correctly earthed / grounded in accordance with current area legislation.

3.2 General safe Operating practice.



Always follow good laboratory practice when using this equipment. Give due recognition to your company's safety and legislative health & safety procedures and all associated legislation applicable to your areas of operation. Check laboratory procedures for substances being heated and ensure all hazards (e.g. explosion, implosion or the release of toxic or flammable gases) that might arise have been suitably addressed before proceeding. When heating certain substances the liberation of hazardous gases may require the use of a fume cupboard or other means of extraction.



If the Hot surface warning symbol is illuminated or flashing on the front control panel, then the agitation plate or if fitted reaction block is at a temperature above 50°C. (±4°C).



Ensure equipment is used on a clean, dry, non-combustible, solid work surface with at least 300mm suitable clearance all around from other equipment.



Do not position the product so that it is difficult to disconnect from the mains supply.



Do not immerse unit in water or fluids.



Do not spill substances onto this unit. If spillage does occur, disconnect unit from mains supply and follow instructions as detailed in Section 'Maintenance'.



To prevent electronic overheat and potential fire **Do not** cover your Agitation Block / or Fan Grills when connected to the mains power supply. ***Even with heat and agitation facility turned off.***



It is **not** recommended to leave any heating apparatus unattended during operation.



Only use Original Equipment manufacture's spares and accessories. Ref Section 10.



The equipment is not spark, flame or explosion proof and has not been designed for use in hazardous areas in terms of BSEN 60079-14:1997. Keep flammable, low flash point substances away from the apparatus.



Do not operate or handle any part of this product with wet hands.



Do not touch your Agitation place or block when 'Hot Surface Warning Symbol' is illuminated or flashing.



Do not lean or stretch over your this product, glassware and fixings when in use.



Do not leave this product switched on without a charged flask(s) in place.



Do not place a cold glass vessel into a hot block.



Keep the Mains Plug and Lead set cable away from the heating surface.

4 UNPACKING & CONTENTS.

4.1 Unpacking (as detailed on the carton of this product).



This product should be received on a wooden pallet with a cardboard cover. **This units weight is 42Kg.** Care should be taken when unpacking it. Cut the strapping and open the cover.

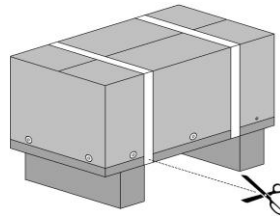

Lift out the Posi-Drive Screwdriver and 13mm Spanner contained within.

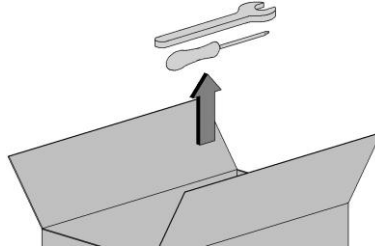

Using the screwdriver provided. Remove all screws from around side of cover.

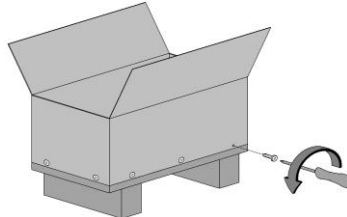

Using the spanner provided remove the four transit bolts located under the pallet.

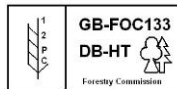
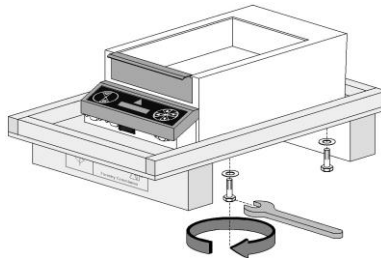

Note: The wood used is certified insect free and conforms to US timber import legislation. Wood used for packing this product is cut from sustainable forests.

4.2 Contents.

Please check the contents of this product against the diagram.

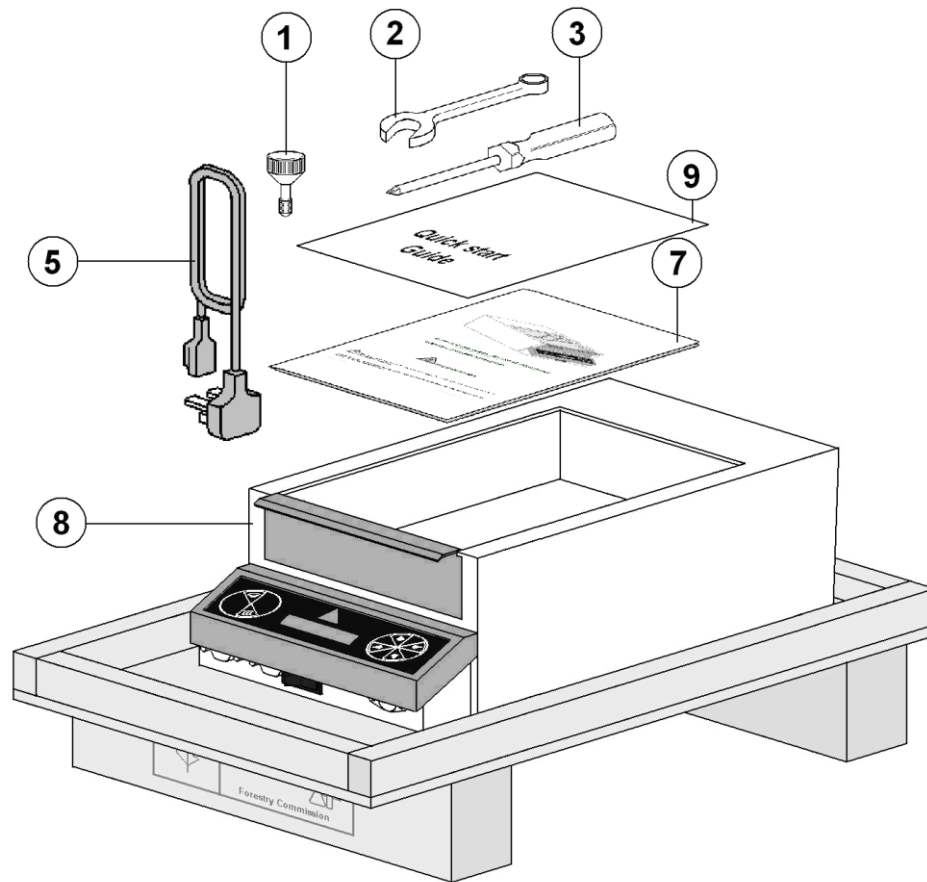

Item No	Description	Qty
1.	Agitation Block Retention Screw (Fitted to the unit).	1
2.	Spanner 13mm.	1
3.	Screwdriver Posi 2 Point.	1
5.	Mains cable.	A/R
7.	Instruction book	1
8.	RS9000 Unit.	1
9.	Quick Start Sheet	1

For your future reference please record your products Serial and Model numbers.	<i>Unit Serial Number</i>	<i>Unit Model/Cat Number.</i>
--	---------------------------	-------------------------------

5 INSTALLATION.

5.1 Electrical and safety installation.

5.2 This equipment is designed to safe under the following conditions:-

- Indoor use.
- Altitude up to 2000 meters.
- Temperatures between 5°C and 40°C.
- Maximum relative humidity 80% for temperatures up to 31°C decreasing linearly to 50% relative humidity at 40°C.
- Mains supply voltage fluctuations up to $\pm 10\%$ of the nominal voltage.
- Transient overvoltages typically present on the mains supply.
- Applicable rated pollution degree 2.



5.3 This equipment must be earthed / grounded to a fixed earth / grounded mains socket outlet. The mains supply is to be earthed / grounded in accordance with current legislation.

5.4 Ensure only the correct rated mains input fuses are fitted. (Where applicable ensure the correct mains cable fuse if fitted). See Technical Information Section 8 of this Instructions book.

5.5 Check the voltage on the product data label of this unit. Ensure the rating conforms to your local supply.

5.6 It is recommended this unit be connected to a mains supply source which incorporates an RCD or GFCI device.

5.7 The unit is supplied with a moulded plug and mains lead set wired as follows.



Green / Yellow or **Green** = **Earth / Ground**
Blue or **White** = **Neutral**
Brown or **Black** = **Live / line hot.**

6 ENVIRONMENTAL PROTECTION.

6.1 Electrothermal has given due consideration to environmental issues within the design and manufacturing process without compromising end product performance and value.



6.2 Packaging materials have been selected such that they may be sorted for recycling.



6.3 At the end of this product and accessories life, it must not be discarded as domestic waste. Ref: EU Directive 2002/96/EC on Waste Electrical and Electronic Equipment Directive (WEEE). Please contact your distributor for further information. For end users outside of the EU, consult applicable regulations.

6.4 This product should only be dismantled for recycling by an authorised recycling company.



If the equipment has been exposed to spillage or contamination, the Responsible Body is responsible for carrying out appropriate decontamination. If hazardous material has been spilt on or inside the equipment, decontamination should only be undertaken under the control of the Responsible Body with due recognition of possible hazards. Before using any cleaning or decontamination method, the Responsible Body should check with the manufacturer the proposed method will not damage the equipment.

Prior to further use, the Responsible Body shall check the electrical safety of the unit. Only if all safety requirements are met can the unit be used again. The above procedure is intended as a guide. Should spillage occur with a toxic or hazardous fluid then special precautions may be necessary.

Decontamination Certificate.

Note: In the event of any part of this unit becoming damaged, the damaged item(s) should be returned to the manufacturer for repair accompanied by a decontamination certificate. **Copies of the Certificate are available from Distributor/Manufacturer. Appendix A of this instructions book may be copied and enlarged. At the end of life this product must be accompanied with a Decontamination Certificate.**

Bibby Scientific's Electrothermal branded product range is registered with the Environment Agency under the name of as Electrothermal Engineering Limited as being a producer of WEEE (Waste Electronic and Electrical Equipment) through b2b Compliance, an authorised waste collection compliance scheme.

7 PRODUCT OPERATION.

This unit has been designed for safe operation when used as described in accordance with the Instruction book.

Note: Failure to use this equipment in accordance with the manufactures Instructions book may compromise your basic safety protection afforded by this equipment and may invalidate the terms of the Warranty / Guarantee.

7.1 Overview

This product ha been designed for easy operation. The illustrations show a detailed layout of this product.

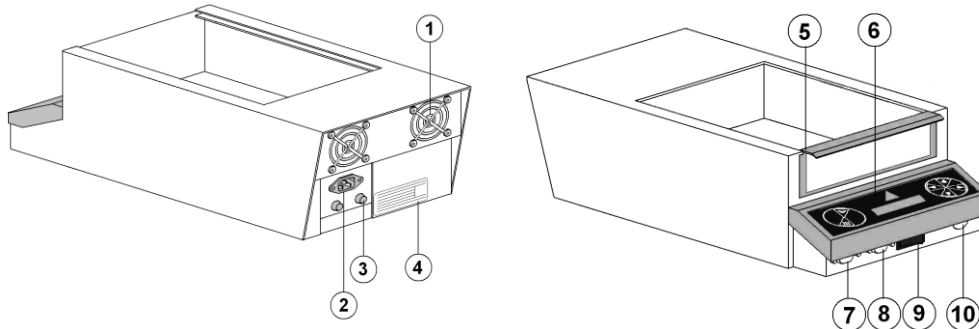

Item	Description.
1	Fans (electronic cooling)
2	IEC mains input socket
3	Fuses
4	Data plate
5	Door (reaction block loading).
6	Control panel with display
7	RS232 data transfer socket
8	RS485 data transfer plug
9	On / Off switch
10	Probe connection din plug.

7.2 Installing the Reaction Block

Push down on the front sliding door. Unscrew the locking screw and remove.

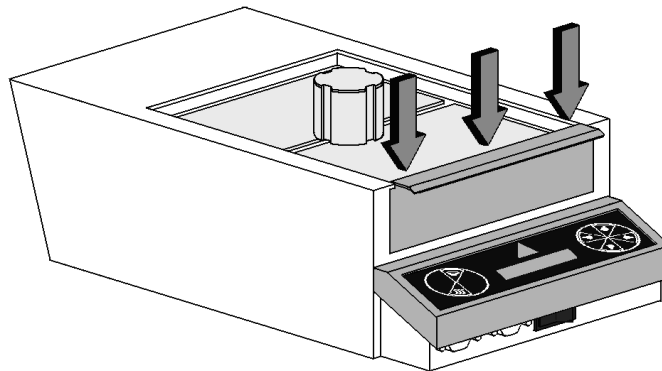

Carefully slide the Reaction Block into position ensuring the central screw of the reactor block is located firmly into the slot provided on the slide plate.

Fasten the locking screw back into position through the front hole in the Reaction Block.

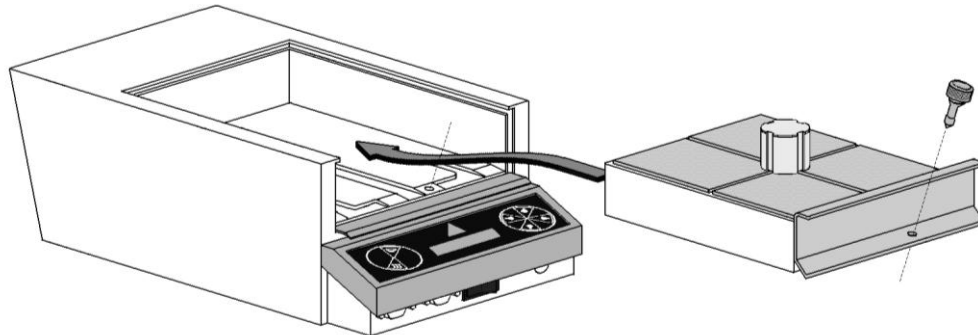

7.3 General Information.

NOTE: For best heating consistency across the Reaction Block the underside of the block needs to make good contact with the Agitation Plate. A damaged underside on your Reaction Block may impair heating performance. For best results the screw height from the under-surface of the Reaction Block to the top of the screw head should be 3.7mm to 3.9mm.

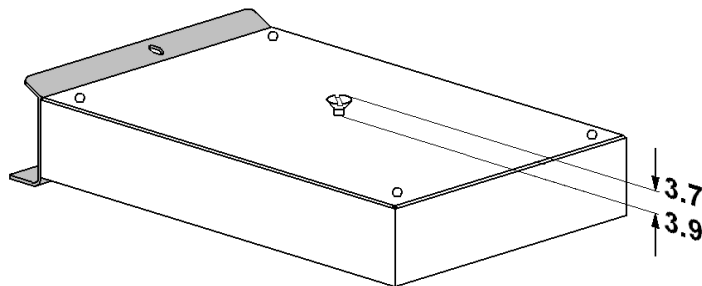

NOTE: The surface of the Agitation Plate may be slightly discoloured. This discolouration is normal and occurs during the testing stage of manufacture when the Agitation Plate is first heated up.

NOTE: If this product has been stored in a damp condition, allow time for the unit to thoroughly dry out before use.

7.4 General Operation.

7.4.1 Initial Power On.

Insert the Mains Lead into the Mains Socket as shown in. Ensure the mains supply voltage is the same as detailed on the data plate.

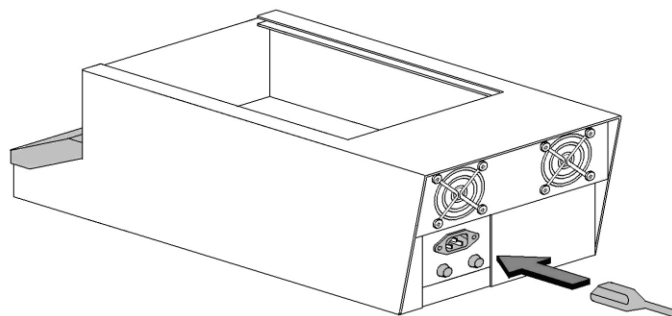



WARNING If the Hot Surface Warning Symbol is flashing on the front control panel then the agitation plate or the reaction block is at a temperature greater than **50°C** ($\pm 4^\circ$).

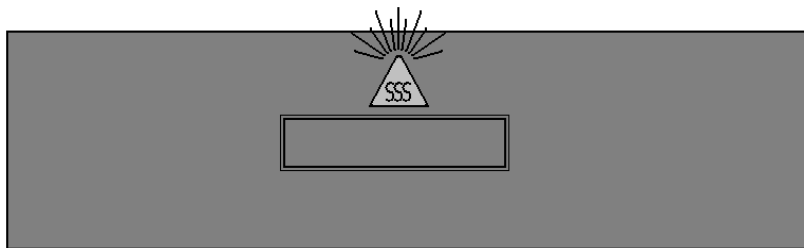

Turn the Reaction Station on by pressing the I/O rocker switch located on the front of this product. The display panel with digital display will now illuminate.

This product will perform a status self-check before displaying the firmware version for a couple of seconds.

Note: If the hot surface warning symbol was flashing before power up it will now stop flashing and remain on constantly to indicate the agitation plate or the reaction block is at a temperature greater than 50°C.

7.4.2 Emergency Stop.

This product Agitation Reaction Station can be stopped rapidly in case of emergency by pressing down on the front sliding door. The front display will indicate a 'Door Open' condition. Heating and stirring activities will stop. To reset, close the door and press the function key zones on the front panel to reactivate.

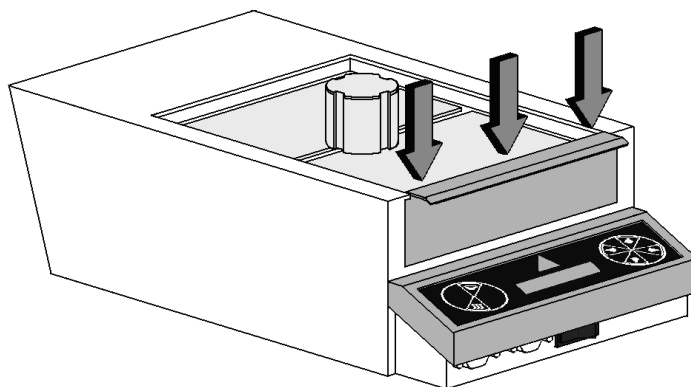

Note: Under Emergency stop condition the agitation plate position will **not** stop in the auto park position.

7.4.3 Temperature Selection and Operation.

On 'Power up,' this product will automatically default to the previous used settings.

Note: On the first 'Power up' this product will defer to the factory settings of 000 for the temperature and 100 for the agitation speed. See for front screen explanation.

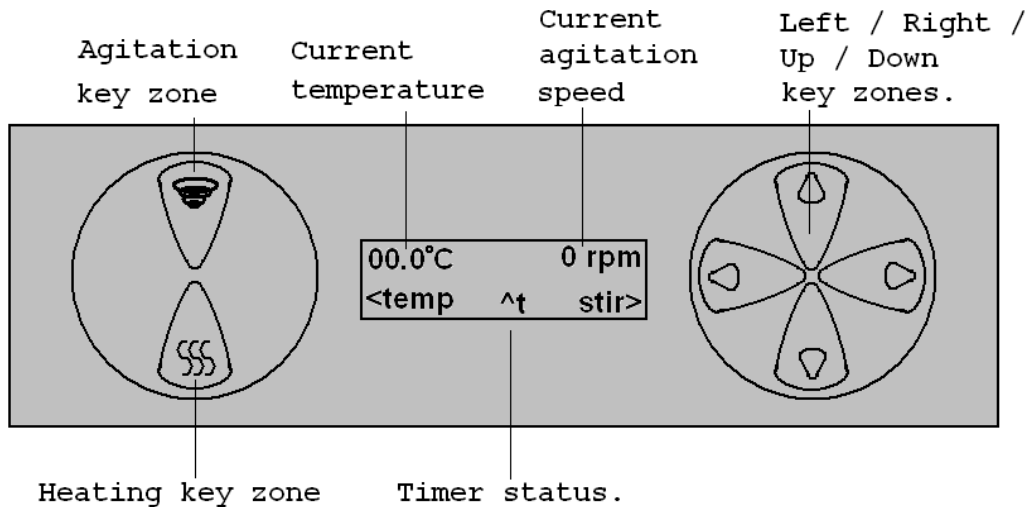

Front Screen display.

Touch the left hand illuminated key zone from the group of four key zones on the control panel to move into temperature selection mode. The direction is indicated by the (<) symbol next to the word 'temp' on the display.



Touch the right hand direction key zone to activate the temperature selection mode.

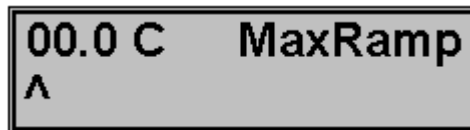

Touch the left or right hand direction key zones to move the display cursor to select a change in the hundreds, tens or unit temperature values.

Touch the up and down key zones to select the temperature value.

With the desired temperature has been selected touch the temperature key on key zone.

☺ (The key zone symbol will now flash red to show the heating function is operational, once the set temperature is reached flashing will stop and the key symbol will remain constantly illuminated red).

To turn off the heating facility, touch the temperature key zone once more.

7.4.4 Temperature Ramp rate Selection.

Note: Don't forget to set the target temperature when setting the temperature ramp rate..

The heating ramp rate is selected from the heating menu. From the front screen touch the left hand key zone until the cursor is sitting under the text 'MaxRamp'

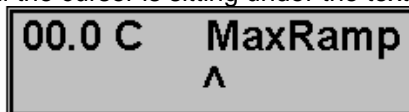

Touch the up key zone to display degrees/minute temperature rise. Use the up arrow key to select the time period required.

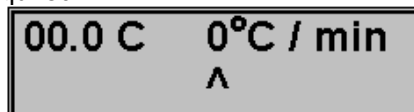

Touch the heating key zone to commence heating.

As previous, the key zone symbol will now flash red to show the heating function is operational, once the set temperature is reached flashing will stop and the key will remain illuminated red.

Note: If the keypad remains untouched for more than 1 minute this product will revert to the front screen display with your setting retained.

7.4.5 Agitation Speed Selection.

To select the agitation speed facility, touch the right hand key zone to move into the stir speed selection mode. The direction is indicated by the arrow (>) next to the word 'stir' on the display.

Touch the left and right hand direction key zones on the control panel to move into the agitation speed setting mode.



Touch the right hand key zone to activate the agitation speed selection. Touch the up and down key zones to select the desired stir speed.

Note: the cursor can only be move between the 100' and 10's rpm parameters when selecting the desired agitation speed.



Repeat pressing the right key to take you back to the from display screen.

Turn on the agitation facility by touching the agitation function zone.



(The key zone symbol will now flash red to show the stirring function is operational, one the required stir speed has been reached the key will stop flashing and the key will remain illuminated red).

To turn off the agitation facility, touch the agitation function zone again.

Note: During manufacture every effort has been made to run in this product, however, it may require an additional running in. If 600rpm agitation speed is selected the first time you use this product it may trip into fault condition "Motor H/C" (Motor high current). Turn it off, then on. Select an agitation speed less than 500rpm. After 50 hours running you RS9000 should be run in and maximum agitation speed may be selected. If fault continues please contact your supplier.

7.4.6 Agitation Speed Ramp Rate Selection.

Note: Don't forget to set the target Agitation speed when setting the Agitation ramp rate. The agitation is selected from the stirring menu. From the front screen touch the right hand key zone and go into the agitation set up. Touch the right hand selection key zone until the cursor is sitting under the '0 min'



The agitation speed may now be entered in rpm rise over intervals of one minute. (rpm/ 1 min). Repeat pressing the right key to take you back to the from display screen.

Touch the agitation selection key zone to activate the facility.
As previous (The key zone symbol will now flash red to show the agitation function is operational, once the set agitation speed is reached flashing will stop and the key will remain illuminated red).

Note: As previous, if the keypad remains untouched for more than 1 minute this product will revert to the front screen display with your setting retained.

7.4.7 Timer Operation.

A timer facility can be set to turn off the heater facility. The timer can be set in 1 hour intervals from 1 hour to 99 hours.

Note: The timer facility will only turn off the heating function. Agitation remains operational.

The timer function is selected from the front screen menu. Before selecting the timer, set the required temperature and, if required the ramp rate). Press the heater on key to commence the heating function.

The **^t** indicates timer selection by touching the up key. Touch the up key once and the screen will now look like.

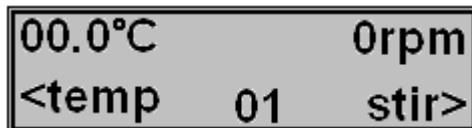

Repeat pressing the up key to change the hours until the required time period is selected. Press the down key to reduce the hours selected.

The timer will count down by the hour indicating the remaining time on period before heating facility is deactivated. When the heating facility is deactivated the red key zone illumination will be extinguished and the front screen menu will again display the **^t** symbol.

7.4.8 Probe Operation (Optional).

An optional probe can be purchased and plugged into the din socket located on the front panel. When a probe is seen by this product the letter **e** will appear on the front panel indicating external temperature device connected.

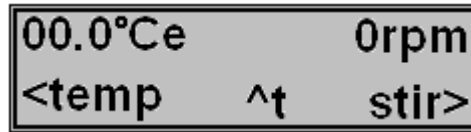

Temperature is set as described. ***The temperature remains controlled by the internal function of the unit.***

The probe provides the facility to measure the temperature of your sample. To heat your sample, set this product to the required temperature. Insert the probe in your sample and turn on the heat facility. Due to the number of agitation block variations the probe temperature will not reach that of the specified set temperature. This has been specifically designed to protect sensitive samples from over temperature damage. You will need to gradually increase the selected temperature until the required sample temperature is reached.

If using PC control software an 'Off set' can be entered.

7.5 Connecting the Data Cable RS232 / RS485.

Refer to Robotic System Instruction book for control input information. Connect 9-way cable to Robotic System. Connect the 'D' type 9-way connector to the appropriate 232 / 485 socket. Fasten the plug of the data cable to the socket by screwing tight the thumb screws of the 'D' type 9-way connector.

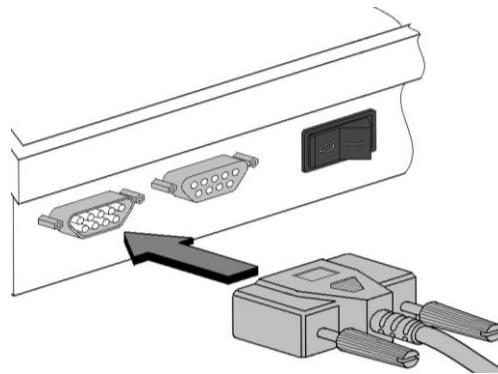

7.6 Installation onto a Robotic System

Note: This activity should be undertaken in conjunction with the Instructions book supplied with the Robotic Work Station.

Lift the Reaction Station carefully into the Robotic System ensuring the location pegs pass up through the location holes in the feet of the Reaction Station. Refer to Robotic System Guide for location peg adjustment. Refer to Robotic System Guide should the Reaction Station require clamping.



NOTE: The Reaction Station is heavy. Lifting it into a Robotic System will require two people.

7.7 Remote Control via RS232.

The Software to access this option can be supplied on request.

Full control of all the functions is available via the RS232 serial port on the front of the RS9000. All necessary communications firmware has been included within the RS9000 electronics. Connection to a host PC will enable unattended control of speed and temperature ramping over a user defined time period. During remote operation the display left and right cursor key zones will remain illuminated red to indicate remote operation.

When this product is dispatched from the factory the baud rate setting will be 9600. An 'Auto Baud Rate' facility will automatically track the baud rate of a host PC and adjust any settings required automatically.

7.7.1 RS232 Pin Configuration.

PC			RS9000	
Not Used	Pin 1		Pin 1	Not Used
Transmit	Pin 2		Pin 2	Received
Received	Pin 3		Pin 3	Transmit
Not Used	Pin 4		Pin 4	Not Used
Ground	Pin 5		Pin 5	Ground
Not Used	Pin 6		Pin 6	Not Used
Not Used	Pin 7		Pin 7	Not Used
Not Used	Pin 8		Pin 8	Not Used
Not Used	Pin 9		Pin 9	Not Used

7.8 Remote Control via RS485.

The RS485 port is to be used only in conjunction with Gilson control protocols.

The RS9000 employs an auto RS232 / RS485 detection for connection to peripheral equipment.

7.8.1 RS485 Pin Configuration.

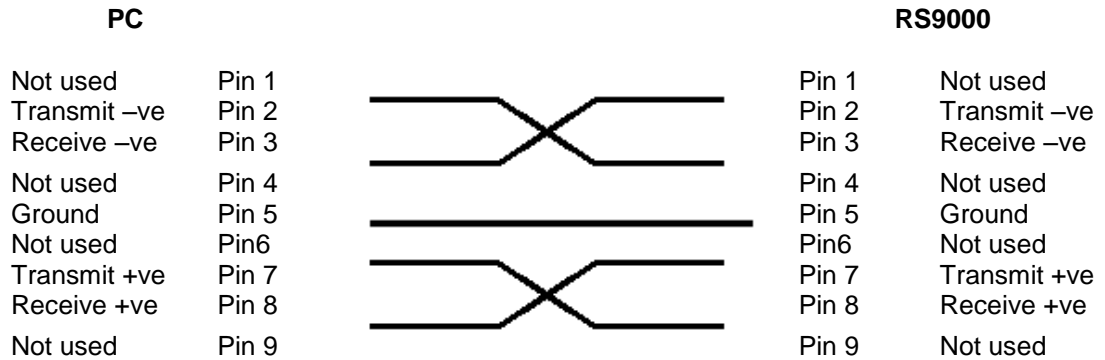

8 TECHNICAL SPECIFICATION.

8.1 Specification.

Mains Supply Power.	230V-AC or 115/100V-AC @ 50/60Hz
Mains Power Lead set (UK) 13A BS1362	3 core earthed / ground. 2 meters long Moulded IEC plug and Lead set – supply cord H0 V V-F- Replace only with equivalent cable.
Mains Power Lead set (Europe)	3 core earthed / ground. 2 meters long Moulded IEC plug and Lead set – supply cord H0 V V-F- Replace only with equivalent cable.
Mains Power Lead set (USA)	3 core earthed / ground. 2 meters long Moulded IEC plug and Lead set – supply cord SJT VW 1- Replace only with equivalent cable.
Lead set plug fuse (UK – only)	5A
Power Consumption	900W
Operating Ambient Temperature	5°C to 40°C
Heating Temperature Range	Ambient + 5 to 150°C
Timer Range	1 to 99 hours.
Agitation Speed	100 to 600 RPM.
LCD Display	Backlit blue double line 13 dot matrix.
Fuse Type and Rating	230V- F10A Quick Blow 1 ¼” 115 / 100V - F12A Quick Blow 1 ¼”
Glass touch panel	3mm clear with 2mm anti reflective clear with a toughed grey laminate bonded sandwich.
Touch key zones	Capacitance sensor touch.
Maximum load weight.	7 kg. (excluding reaction block weight).

8.2 The Ingress protection rating for this product is classified as IPX1.

8.3 Dimensions & Weight.

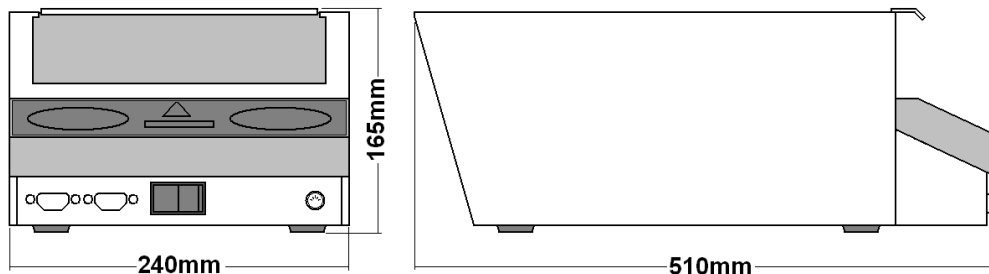

Weight 42Kg (unpacked) without a reaction block in position.

9 MAINTENANCE.

9.1 General Information.



Unplug the unit from the mains voltage supply and allow it to cool before undertaking any maintenance tasks.



Maintenance should only be carried out under the direction of the Responsible Body, by a competent electrician. Failure to do so may result in damage to the product and in extreme cases be a danger to the end user.

With proper care in operation this equipment has been designed to give many years of reliable service. Contamination or general misuse will reduce the effective life of this product and may cause a hazard.

Maintenance for the unit should include:

- Periodic electrical safety testing (an annual test is recommended as the minimum requirement).
- Regular inspection for damage with particular attention to the mains lead and plug set.
- Routine cleaning of the equipment should be undertaken using a clean cloth.

DO NOT USE SOLVENTS FOR CLEANING ANY PART OF THIS EQUIPMENT.

9.2 Fuse Replacement.

The mains fuse holders are located at the rear of this product. Refer to Technical specification, 'Fuse Rating' for correct fuse type and rating. Turn this product Agitation Reaction Station off and remove it from the mains supply. ① Unscrew both fuse holder caps from the fuse housings and ② remove the fuses. Inspect fuse for damage. Fit replacement fuse(s) and refit into fuse housing. (See 8.1 for fuse type and specification).

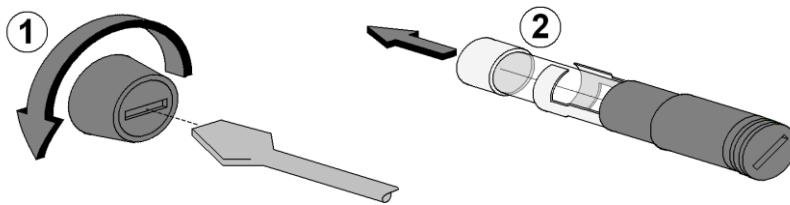

9.3 Fault Conditions.

This product has a self diagnostic check facility. If one of the following fault condition messages are seen please take the following action:-

Fault	Action
Motor H/C	Refer to note paragraph 7.9. Check for obstruction between Reaction Block and product case. If fault is persistent call for service.
Motor Speed Err	If fault is persistent call for service.
Probe L/Z	Internal temperature sensor damaged. Call for service.
Door Open	Close door.

9.4 Servicing.

This product should be serviced by your Bibby Scientific Service Engineer or by an agent on behalf of the manufacture. If in doubt contact Bibby Scientific. See Section 11.

Servicing by your Electrothermal Engineer or by an agent on behalf of the manufacture will include the following:-

- Motor Brush inspection and replacement if required.
- Drive Belt inspection and tension adjustment.
- Wiring inspection with reference to all moving parts.
- Sound and noise evaluation.
- Lubrication of mechanical drive.
- Performance Diagnostic evaluation.

This product has the facility to retain diagnostic evaluation data which will be accessed by the Service Engineer for use during service.

9.5 Decontamination.



If the equipment has been exposed to spillage or contamination, the Responsible Body is responsible for carrying out appropriate decontamination. If hazardous material has been spilt on or inside the equipment, decontamination should only be undertaken under the control of the Responsible Body with due recognition of possible hazards. Before using any cleaning or decontamination method, the Responsible Body should check with the manufacturer the proposed method will not damage the equipment.

Prior to further use, the Responsible Body shall check the electrical safety of the unit. Only if all safety requirements are met can the unit be used again. The above procedure is intended as a guide. Should spillage occur with a toxic or hazardous fluid then special precautions may be necessary.

Decontamination Certificate.

Note: In the event of any part of this unit becoming damaged, the damaged item(s) should be returned to the manufacturer for repair accompanied by a decontamination certificate. **Copies of the Certificate are available from Distributor/Manufacturer. Appendix A of this instructions book may be copied and enlarged. At the end of life this product must be accompanied with a Decontamination Certificate.**

9.6 Spillage.

In the event of spillage switch off and unplug this product from the mains electrical supply. Remove the Reaction block and wipe off all excess liquid from the agitation plate and surrounding area using an absorbable soft cloth. Allow sufficient time for any ingressed liquid to evaporate before commencing with use.

If in doubt please consult Customer support. Refer to section 11.

10 PARTS & ACCESSORIES.

AZS4017	Fuse 10A (230V)
AZS4025	Fuse 12A (115V)
AZS4141	Heater Cartridge (110V)
AZS4142	Heater Cartridge (230V)
M7876	Motor Brushes. (2 per)
AZ6745	UK Mains Lead
AZ6746	US Mains Lead
AZ6747	Euro Mains Lead
PS80052	Reaction Block for test tubes, 96 x 16mm
PS80064	Reaction Block for test tubes, 40 x 24mm
PS80074	Reaction Block for 4 x standard Microtitre plates
PS80047	Reaction Block for 4 x 96 well PTFE Microtitre plates
PS80065	Reactor for Charybdis Calypso System
PS80048	96 well PTFE Microtitre plate, 9 x 8mm ID
PS80114	Reaction Block for 96 x 1.5ml Eppendorf tubes
PS80049	96 well PTFE Microtitre plate lid
PS80051	96 well PTFE Microtitre complete with lid
AZ140940	Probe (external).

APPENDIX 'A'. DECONTAMINATION CERTIFICATE.

Bibby Scientific Limited. Beacon Road, Stone, Staffordshire ST15 0SA. Great Britain

Tel: +44(0)1785 812121. Fax: +44(0)1785 810405 E-mail: electrothermalhelp@bibby-scientific.com

DECONTAMINATION CLEARANCE CERTIFICATE

For the Inspection, Repair or Return of Medical, Laboratory or Industrial Equipment.

Prior to a Service Engineer working on equipment that has been in an environment where substances hazardous to health may have been used, you are requested to provide the following information:

CUSTOMER DETAILS

Company:- Address:-
Department:-
Contact Name:-
Tel No:-
Fax No:- Post Code:-

Product Description

Model No:- Serial No:-

Has the equipment been exposed to any of the following, Please answer all questions by deleting YES/NO as applicable and by providing details in section 2 below.

A. Blood, body fluids, Pathological specimens	YES/NO	Provide details if YES
B. Biodegradable material that could become a hazard	YES/NO	Provide details if YES
C. Other biohazard	YES/NO	Provide details if YES
D. Chemical or substances hazardous to health	YES/NO	Provide details if YES
E. Radioactive substances State name(s) and quantities of isotopes and checks made for residual activity	YES/NO	Provide details if YES
F. Other hazards	YES/NO	Provide details if YES

2. Please provide details of any hazard present as indicated above. Include details of names and quantities of agents as appropriate:-

3. Your method of decontamination (please describe):-

4. Are there likely to be any areas of residual contamination (please specify)

I declare that the above information is true and complete to the best of my knowledge and belief.

Authorised signature:-

Name (please print):-

Title/Position:-

For and behalf of:-

Date:-

11 CUSTOMER SUPPORT.

For help and support in using this product, please contact Customer Services at the following address.

Bibby Scientific Limited.

Beacon Road,
Stone,
Staffordshire ST15 0SA,
Great Britain.

Tel: +44(0)1785 812121
Fax: +44(0)1785 810405

For the America's and Canada, contact:

Techne Incorporated, 3 Terri Lane,
Suite 10 Burlington, NJ 08016 USA.

Toll free:800-225-9243Tel: 609-589-2560
Fax: 609-589-2571
Email: labproducts@techneusa.com
Http www.techneusa.com

- General enquiries :
info@bibby-scientific.com
- Order enquiries :
sales@bibby-scientific.com
- Technical support :
electrothermalhelp@bibby-scientific.com
- www.electrothermal.com

12 NOTES.

13 EC DECLARATION OF CONFORMITY.

CE marked products and associated accessories covered by this Instruction book conform to the essential requirements of the following directives:

EMC Directive.

Low Voltage Directive.



Thank you for reading this data sheet.

For pricing or for further information, please contact us at our UK Office, using the details below.



UK Office

Keison Products,

P.O. Box 2124, Chelmsford, Essex, CM1 3UP, England.

Tel: +44 (0)330 088 0560

Fax: +44 (0)1245 808399

Email: sales@keison.co.uk

Please note - Product designs and specifications are subject to change without notice. The user is responsible for determining the suitability of this product.