



Gas Measurement Instruments Ltd

Leak Surveyor User Handbook



Q 09760

Issue 2

28/07/04

Part Number: 42207

GMI welcomes comments on all our publications. Your comments can be of great value in helping us to improve our customer publications. Please send any comments that you have to our Sales Department at GMI. Contact details are provided inside the back cover of this handbook.

Instrument Service / Repair contact details are also provided inside the back cover of this handbook.

COPYRIGHT

This User Handbook is copyright of Gas Measurement Instruments Ltd (GMI) and the information contained within is for use only with the Leak Surveyor instrument. Reproduction, in whole or in part, including utilisation in machines capable of reproduction or retrieval without written permission of Gas Measurement Instruments Ltd is prohibited. Reverse engineering is not permitted.

LIABILITY

Every care has been taken in the preparation of this document, but GMI Ltd do not accept any responsibility for errors or omissions and their consequences. Information in this document is subject to change without notice. This document does not constitute a specification or basis for a contract. Your statutory rights under law are not affected.

MODIFICATION NOTICES

GMI aim to notify customers of relevant changes in the product operation and maintain this manual up to date. In view of the policy of continuous product improvement there may be operational differences between the latest product and this manual.

This Handbook is an important part of the Leak Surveyor product. Please note the following points:

- It should be kept with the instrument for the life of the product.
- Amendments should be attached.
- This Handbook should be passed on to any subsequent owner/user of the instrument.
- Although every care is taken in the preparation of this Handbook it does not constitute a specification for the instrument.



SOFTWARE

Software supplied on EPROM or similar device for use in a particular product, may only be used in that product and may not be copied without the written permission of Gas Measurement Instruments Ltd. Reproduction or disassembly of such embodied programmes or algorithms is prohibited. Ownership of such software is not transferable and GMI Ltd does not warrant that the operation of the software will be error free or that the software will meet the customer's requirements.

DISPOSAL ADVICE

When no longer in use, dispose of the instrument carefully and with respect for the environment. GMI will dispose of the instrument without charge if returned to the factory.

SAFETY

- The instrument must be regularly serviced and calibrated by fully trained personnel in a safe area.
- **Batteries:** Alkaline batteries or *Rechargeable battery pack must be exchanged (*and recharged) in a safe area and fitted correctly before use. Never use damaged batteries or expose to extreme heat. See Section 5: OPERATOR MAINTENANCE.
- Only GMI replacement parts should be used.
- If the instrument detects gas, follow your own organisation's procedures and operational guidelines.
- The combustion chamber is a flameproof assembly and must not be opened in the presence of a flammable atmosphere.
- Leak Surveyor instruments are certified as EEx iad IIB T3
(-20°C ≤ Tamb ≤ 50°C). BAS03ATEX2448X   II 2 G.



UL Class 1 Groups C and D.

- This equipment is designed and manufactured to protect against other hazards as defined in paragraph 1.2.7 of Annex II of the ATEX Directive 94/9/EC

Any right of claim relating to product liability or consequential damage to any third party against GMI is removed if the warnings are not observed.

AREAS OF USE

Exposure to certain chemicals can result in a loss of sensitivity of the flammable sensor. Where such environments are known or suspected it is recommended that more frequent response checks are carried out. The chemical compounds that can cause loss of sensitivity include Silicones, Lead, Halogens and Sulphur. Do not use instrument in potentially hazardous atmospheres containing greater than 21% Oxygen. The enclosure material is polypropylene and must not be exposed to environments which are liable to result in mechanical or thermal degradation or to damage caused by contact with aggressive substances. Additional protection may be required in environments where the instrument enclosure is liable to damage.

STORAGE, HANDLING AND TRANSIT

The batteries in the rechargeable pack contain considerable energy and care should be taken in their handling and disposal. Battery packs should be removed if the instrument is stored for longer than 3 months. The instrument is designed to handle harsh environments. The sensing elements are sealed to IP54 and the rest of the instrument to IP64. If not subject to misuse or malicious damage, the instrument will provide many years of reliable service. The instrument contains electrochemical sensors with a life of 2 years. Under conditions of prolonged storage the sensors should be removed. The sensor contains potentially corrosive liquid and care should be taken when handling or disposing of the sensor, particularly when a leak is suspected.

REVISION RECORD

Date	Pages	Description Of Change
Issue 1 24/07/03	All	New Handbook
Issue 2 28/07/04	All	Appendix 'C' included to provide Quick Operating Instruction translations

CONTENTS

COPYRIGHT	i
LIABILITY	i
MODIFICATION NOTICES	i
SOFTWARE	i
DISPOSAL ADVICE	i
SAFETY	ii
AREAS OF USE	ii
STORAGE, HANDLING AND TRANSIT	ii

REVISION RECORD	iii
-----------------------	-----

INTRODUCTION	1
--------------------	---

GENERAL INFORMATION	3
Ranges of Operation	3
ppm Flammable Range (Semiconductor Sensor), 0 – 10000 ppm Methane	3
LEL, 0 to 100%	4
Volume Gas, 0 to 100 %	5
Alarms	5
LEL Range	5

Alarm Functions	6
ppm Geiger (Semiconductor Sensor Range)	6
Construction	6
Batteries	7
Alkaline (LR20) Batteries	7
Rechargeable Battery Pack	7
Filters	8
Standard Probe Handle Assembly	8
Carpet Probe Assembly	8
Survey Probe Handle Assembly	8
Liquid Crystal Display (LCD)	9
Before Use Checks	9
<hr/>	
OPERATING INSTRUCTIONS	11
Instrument Features	11
Switch Panel	12
Connection of Probe	13
Operation	13
Switching On	13
Calibration Due Date Features	14
Instrument Pump High Speed / Off Selection	15
Switching Instrument Off	15
Changing Range	15
Clearing Alarms	16
Activate Audible Geiger Indication	16

Zeroing the ppm Range Indication	16
Switch Operation Summary	17
Operator Messages / Fault Flags	18
<hr/>	
PROBES	21
Standard Probe and Handle Assembly	21
Carpet Probe	22
Swan Neck Probe / Bellows Probe	23
<hr/>	
OPERATOR MAINTENANCE	25
Rechargeable Battery Pack	25
Standard Charger	25
Flatbed Charger	26
Smart Charger	26
Replacing the Battery Pack	27
Recharging the Battery Pack	28
Replacing Alkaline (LR20) Batteries	28
Filter Replacement	30
Standard Probe Handle Assembly	
- Part No. 12481	30
Carpet Probe Assembly	
- Part No. 13535	32
Survey Probe Handle Assembly	
- Part No. 13561	35

CALIBRATION	39
Calibration Validity	40

ACCESSORIES	41
-------------------	----

ADDITIONAL INFORMATION	45
Training	45
World Wide Web	45

TYPICAL OPERATING PARAMETERS	A-1
Size	A-2
Weight	A-2
Operating Temperature	A-2
Humidity	A-2
Construction	A-2
Display	A-2
Sampling System	A-2
Power Source	A-3

PROBE APPLICATIONS	B-1
Small Plastic (Solid End) Probe	B-1
Small Plastic (Open End) Probe	B-2
Carpet Probe	B-3
Bellows Probe	B-4
Swan Neck Probe	B-6

OPERATING INSTRUCTIONS	C-1
English	C-2
Deutsch (German)	C-6
L'italiano (Italian)	C-10
Svensk (Swedish)	C-14
Dansk (Danish)	C-18
Nederlands (Dutch)	C-22

INDEX	I
-------------	---

INTRODUCTION

The Leak Surveyor is designed for use in leak surveying of underground gas distribution pipes, including pinpointing, barholing and classifying.



The instrument is a highly flexible, four button, portable gas detector which is designed to provide measurement of Parts Per Million (ppm), Lower Explosive Level (LEL) and Volume flammable gas for leak detection and general safety monitoring. In addition to using a fast speed of response semiconductor sensor for ppm measurement, the instrument has a two speed pump and when the high speed is used together with the integral semiconductor sensor, initial external leakage surveys can be performed in the vicinity of property or pipelines, enabling distribution leaks to be quickly found.

The Leak Surveyor monitors continuously and is equipped with both audible and visual 'Geiger' alarm indications on the ppm range.

The Leak Surveyor contains the following ranges:

- 0 to 10000 ppm (semiconductor sensor)
- 0 to 100% LEL
- 0 to 100% Volume Gas

The Leak Surveyor has a variety of user configurable options. This handbook details the default configuration, with possible options detailed in *italic* text.

The Leak Surveyor can be supplied in either a Standard Accessory Case or a Gas Industry Survey Case, able to accommodate a selection of accessories. For a comprehensive list of accessories that can be supplied in each carrying case, and additional accessories available, see Section 7 ACCESSORIES.

The main features of the Leak Surveyor are:

- Rugged polypropylene case, sealed to IP54 rating and suitable for outdoor use.
- Four button operation allowing the user access to all features.
- LCD with backlighting which displays the current gas readings (in both digital and analogue forms) together with operational and status information.
- Audible and visual alarms (Alarm levels are pre-set).
- Directly interfaces with the GMI Auto Calibration Units.

GENERAL INFORMATION

Ranges of Operation

The instrument calibration gas is shown on the service label and for the purpose of this handbook is assumed to be methane. Instruments calibrated for methane in air should only be used for measuring such mixtures.

ppm Flammable Range (Semiconductor Sensor), 0 – 10000 ppm Methane

This range displays flammable gas parts per million (ppm) content up to 9999 ppm (10000ppm is equivalent to 20% LEL Methane) and ppm is displayed in the top right corner of the LCD.

From 0 to 499 the digital display resolves to 1 ppm, and from 500 to 10000 the digital display resolves to 10 ppm, with the analogue bargraph following in steps of 400ppm.

The ppm range, by default, has the audible and visual Geiger indication configured, that is, they will provide assurance that the instrument is sensing for gas without the need for the operator to constantly view the display.

The ppm range can be manually zeroed by a double press of Switch Three () when the ppm range is selected.

When the instrument is switched on, the audible Geiger indication is disabled, but can be enabled by a single press of Switch Four (.

When the audible indication is enabled, the display alternates between ppm and Aud, as shown in Figure 2.1.

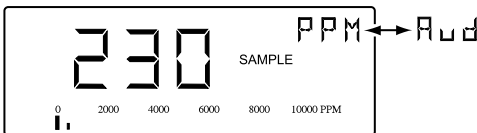

Figure 2.1 ppm Range

LEL, 0 to 100%

The LEL range indicates the explosivity of the flammable gas in the sample. This is displayed as a percentage of the lower explosive limit (LEL) of the gas. For methane 100% LEL corresponds to 5% Volume methane in Air.

When the instrument autoranges to LEL, LEL is displayed in the top right corner of the LCD. From 0 to 10% LEL the digital display resolves to 0.1% LEL. From 10 to 100% LEL the digital display resolves to 1% LEL. The analogue bar graph follows in 4% steps. An example of the LEL display is shown in Figure 2.2.

The detection principle for this range is by a catalytic reaction.



Figure 2.2 LEL Range

Volume Gas, 0 to 100 %

This range displays the total volume of a flammable gas. When the instrument autoranges to Volume Gas, GAS is displayed in the top right corner of the LCD. The digital display resolves the signal to 1% GAS with the analogue bar graph following in steps of 4%. Figure 2.3 shows the Volume Gas display. The detection principle for the Volume Gas range is thermal conductivity.

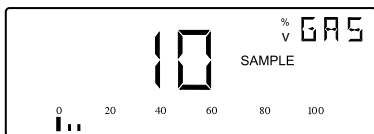

Figure 2.3 Volume Gas Range

Alarms

LEL Range

The LEL range has, by default, audible and visual alarms active. The audible alarm is rated up to 85 dB(A) at 0.3m (1ft.) approx. The visual alarm is a red LED indicator which protrudes from the instrument top plate, allowing viewing from any angle above the top plate.

It is the responsibility of the user to ensure that the alarm levels, where set in the instrument, are appropriate for the safe operation and legal requirements for the country / industry in which the unit is being used.

The Leak Surveyor has the high instantaneous alarm level setting of 20% LEL, activated by default.

Alarm Functions

For the LEL range, the alarm function default is that the alarms will be non-latching and both the audible and visual functions will operate. That is, where an alarm level is exceeded, the instrument LED flashes and the sounder pulses rapidly. These alarms clear automatically when the gas levels fall below the alarm limit.

Non-latching alarms can be acknowledged by a double press of Switch Four (). If, after 60 seconds, the gas detected still exceeds the alarm level, the audible and visual alarm will be re-activated.

Latching alarms must be cleared manually, by a double press of Switch Four () , after the detected gas level has fallen below the alarm limit. The audible and visual functions can also be enabled or disabled ON or OFF.

ppm Geiger (Semiconductor Sensor Range)

The ppm (semiconductor sensor) range has, by default, audible and visual Geiger indication configured. This means that, as the gas concentration increases, the sounder and the LED pulse at an increasing rate, from 0 to 500 ppm, in the 0 to 10,000 ppm range.

Construction

The instrument is housed in a tough, impact resistant, moulded case made of polypropylene.

The top panel is protected by a stainless steel top plate covering a toughened glass LCD cover.

The battery cover (Alkaline) / Battery Pack (Rechargeable) is attached to the main instrument body by means of 2 stainless steel hexagonal screws.

The instrument is sealed against dust and water to IP54 standard. The instrument sensors are protected from dust and water by membrane and cotton filters (when using probe handle assembly - Part No. 12481).

Batteries

Alkaline (LR20) Batteries

Alkaline batteries provide approximately 21 hours operational life at ambient temperature of 15°C to 20°C (59°F to 68°F). When the batteries are low or exhausted it is necessary to fit 4 new batteries to reset the battery indicator to 100%. Do not mix old and new batteries.

An indication of the battery life is displayed during warm up. During operation the 'BAT' alarm flag is displayed when 1 to 2 hours of operating time remain at normal temperature. The instrument may still be used but eventually the 'BAT FAULT' alarm flag will be displayed, at which point the instrument will switch off automatically.

Rechargeable Battery Pack

The GMI rechargeable battery pack is identified, when fitted, by two contacts on end face of pack and provides approximately 18 hours of use from fully charged condition. An indication of the battery life is displayed during warm up. During operation the 'BAT' flag is displayed when approximately 30 minutes operating time is left at normal temperatures.

There are three GMI Battery Chargers: a Standard Charger, a Flatbed Charger and a Smart Charger. The Smart Charger has both slow and fast charge options as well as a serial link for communications with the instrument. See Rechargeable Battery Pack in Section 5 OPERATOR MAINTENANCE.

Filters

Standard Probe Handle Assembly

A number of different filter types are available from GMI. The minimum requirement is a cotton particulate filter and a hydrophobic filter. These filters, incorporated in the probe handle assembly (Part No. 12481), are available from GMI. Filters must be checked at frequent intervals and where appropriate changed to ensure a clean sample path. Any filter which has been contaminated must be cleaned or replaced. See Filter Replacement in Section 5 OPERATOR MAINTENANCE.

Carpet Probe Assembly

A replacement dust filter is available from GMI which is incorporated in the filter housing in the carpet probe assembly (Part No. 13535). Filters should be checked periodically and where appropriate changed to ensure a clean sample path. Any filter which has been contaminated must be cleaned or replaced. See Filter Replacement in Section 5 OPERATOR MAINTENANCE.

Survey Probe Handle Assembly

A Dust or Water Filter Assembly is available from GMI for use with the survey probe handle (Part No. 13561). Either of the filter assemblies can be attached to the probe handle. Filters must be checked at frequent intervals and where appropriate changed to ensure a clean sample path.

Any filter which has been contaminated must be cleaned or replaced. See Filter Replacement in Section 5 OPERATOR MAINTENANCE.

Liquid Crystal Display (LCD)

The LCD shows the current gas readings in both analogue and digital form together with operational and status information. The display is protected by a toughened glass cover. Backlighting is provided to enable the display to be seen under low ambient light conditions.

Before Use Checks

The following checks should be carried out before using the instrument on site:

- The instrument is clean and in good condition.
- The batteries have sufficient power left in them for the intended use of the instrument.
- The filters are clean and in good condition.
- The sample line and aspirator bulb (if used) and any accessories are in good condition and leak free.
- All gas ranges are operational and zeroed correctly.
- The calibration is still valid.

OPERATING INSTRUCTIONS

Instrument Features

The Leak Surveyor front plate features a panel of four operating switches, a backlit LCD screen incorporating the analogue bar graph, a visual alarm LED and an infra red communication port.

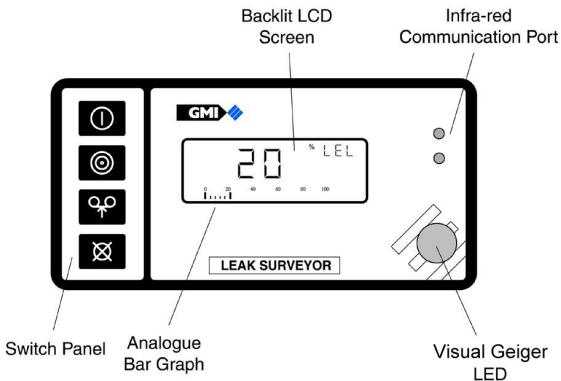

Figure 3.1 Instrument Front Plate

Switch Panel

The Leak Surveyor Switch Panel features four operating switches, as shown in Figure 3.2

A Single Press of any switch will access functions, coloured red, on left hand side of switch panel.

A Double Press of any switch will access functions, coloured blue, on right hand side of switch panel.

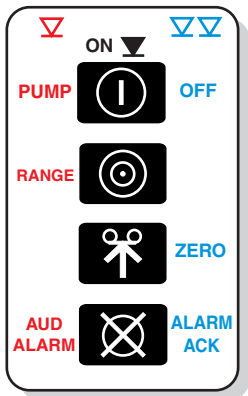





Figure 3.2 Switch Panel

The symbols indicate the operator actions necessary to access all instrument functions:

-  SINGLE PRESS (functions in red)
-  DOUBLE PRESS (functions in blue)
-  SINGLE PRESS and HOLD (to turn instrument ON)

Refer also to paragraph 'Switch Operation Summary' later in this chapter.

Connection of Probe

The Leak Surveyor instrument is equipped to accept probe types listed in Section 4 Probes.

Instrument connection points for all probe types are shown in Figure 3.3

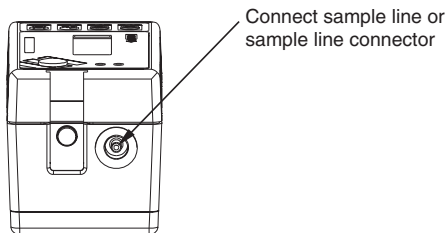



Figure 3.3 Probe Connection

Operation

The instrument is a very flexible combustible gas indicator incorporating a semiconductor sensor which can be utilised for fast response leak detection.

Switching On

Pressing and holding Switch One () turns both the instrument and the pump ON. This initiates the instrument's warm up cycle, as shown in the following example sequence, Figure 3.4. The display of alarm levels after the warm up sequence may be cancelled by a single press of any switch.

All LCD segments displayed



Instrument type Software version

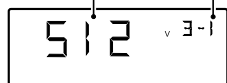

Battery status

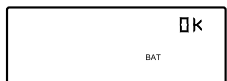

Alarm Level shown
LEL alternates with HI

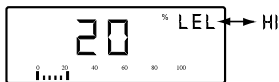

Calibration Due
July 2003

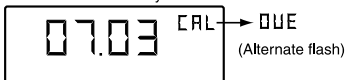

Current detection reading

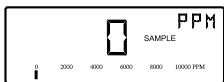

Figure 3.4 Warm Up

Calibration Due Date Features

At the end of warm-up, as shown in Figure 3.4, and before the Leak Surveyor instrument is ready for measuring, the instrument will indicate on the display when the next calibration is due. This will be displayed as month and year, as shown in Figure 3.5:

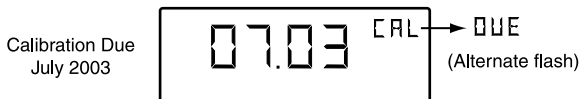



Figure 3.5 Calibration Date

The re-calibration interval pre-set for all Leak Surveyor instruments is twelve (12) months.

This period can be altered, however, you should ensure that the instrument is always within its calibration period prior to use.

Instrument Pump High Speed / Off Selection

A single press of Switch One () when the pump is running, selects (HI) high pump speed. A further press of switch one turns the pump OFF and stops sampling. Pressing switch one again turns the pump back ON at normal speed. The 'SAMPLE' flag is displayed when the pump is running and is extinguished when the pump is switched off.

Switching Instrument Off

A double press of Switch One () turns the instrument off.

There is a five second shutdown sequence during which time, OFF is displayed in the top right hand corner of the display. Single press any one of the four instrument switches to abort shutdown.

Changing Range



Each single press of Switch Two () changes the range. The display cycles through the available ranges in the order: PPM – LEL – PPM etc.

Note: The instrument auto-ranges between LEL and Volume Gas.

Clearing Alarms

A double press of Switch Four () will acknowledge the alarm for 60 seconds if non-latching, *or clear latched alarm if the gas reading is below the alarm set point.*

Activate Audible Geiger Indication

When the ppm (semiconductor sensor) range is selected, by default, the visual Geiger indication will be operational. To activate the audible Geiger indication, press Switch Four (). A further press of Switch Four () mutes the indication.

Zeroing the ppm Range Indication







The ppm (semiconductor sensor) range, when selected, can be zeroed manually.

To zero, a double press of Switch Three () is required and should be carried out in fresh air.

Operation Summary:

- Alarms are always enabled.
- The pump can be switched from ON (normal flow) to HI (high flow) then OFF.
- The instrument does not switch off automatically.

Switch Operation Summary

	 Single Press	 Double Press	 Press & Hold
Switch 1 	Pump Speed On / Hi / Off	Switch OFF Instrument	Switch ON Instrument
Switch 2 	Change Range ppm - LEL - ppm etc.	—	—
Switch 3 	—	Zero ppm	—
Switch 4 	Enable / Disable Audible Geiger (ppm only)	Alarm Acknowledge	—

Operator Messages / Fault Flags

Various messages can appear on the LCD screen to indicate instrument status.

'SAMPLE'

This indicates that the pump is running and the instrument is sampling.

'OFF'

This indicates that the instrument is about to switch off. This command can be cancelled by a single press of any switch.

'SAMPLE FAULT'

This indicates a problem with the instrument's flow due to the sample path being blocked, water ingress, a blocked filter or pump failure. This may also indicate a fault with the instrument's flow fail detection circuitry.

The instrument will alarm and the pump will switch off. The sample path should be checked and Switch One pressed to clear sample fault and re-start the pump.

'CHECK ZERO'

This indicates that there may have been a zero shift due to the presence of gas. Switch off the instrument and switch on again in fresh air.

'ZERO FAULT'

This indicates that the zero is outwith its calibration limits. Switch the instrument off and then on again in fresh air. If the fault does not clear, return the instrument for servicing.

'BAT'

This indicates that the batteries will soon require replacement. At this point there will be approximately 1 to 2 hours left in a set of alkaline batteries, although this figure will vary depending on battery manufacturer, temperature conditions, usage etc. With rechargeable batteries the 'BAT' flag indicates approximately 30 minutes operation left.

'BAT FAULT'

This indicates that the batteries should be replaced immediately.

As the battery power continues to fall, the pump switches off and the LCD flashes a 'BAT FAULT' message. Subsequently the LCD displays 'OFF' and the instrument switches off after approximately 5 minutes. The batteries should be replaced immediately.

'EEEE'

'EEEE' is displayed if the measurement in the ppm (semiconductor sensor) range rises above 9999 (instrument over range).

'1'

This message, which can only appear during power on, indicates that a calibration data error has been detected. The instrument should be returned for servicing.

PROBES

The Leak Surveyor instrument is equipped to accept the following probes and associated accessories:

Standard Probe and Handle Assembly

<u>Part No.</u>	<u>Description</u>
12480	Small Plastic Probe - solid end
13427	Small Plastic Probe - open end
12393	Large Plastic Probe - solid end
12481	Std. Probe Handle Assembly - incl. filters
12712	Clear Sample Line x 1.5 Metres (4ft 10ins.) approx.

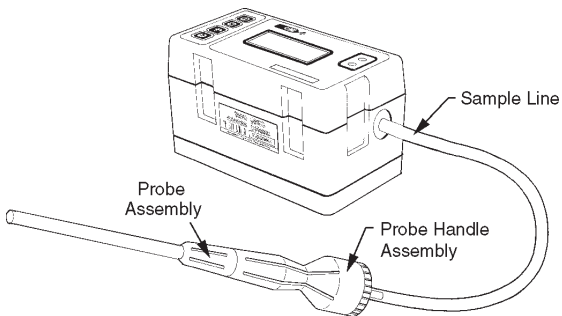

Carpet Probe

<u>Part No.</u>	<u>Description</u>
13535	Carpet Probe Assembly

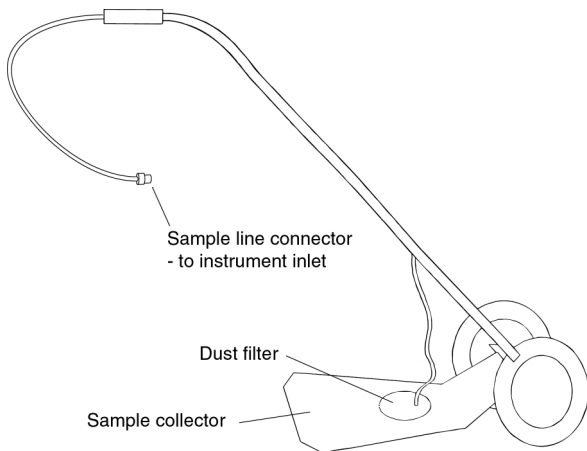

For examples of Carpet Probe and various other probe applications, see Appendix B, PROBE APPLICATIONS.

Swan Neck Probe / Bellows Probe

<u>Part No.</u>	<u>Description</u>
13561	Survey Probe Handle Assembly incl. Sample Line
13562	Probe Adaptor
13565	Swan Neck Probe
13563	Bellows Probe
42184	Dust Filter Assembly
42183	Water Filter Assembly

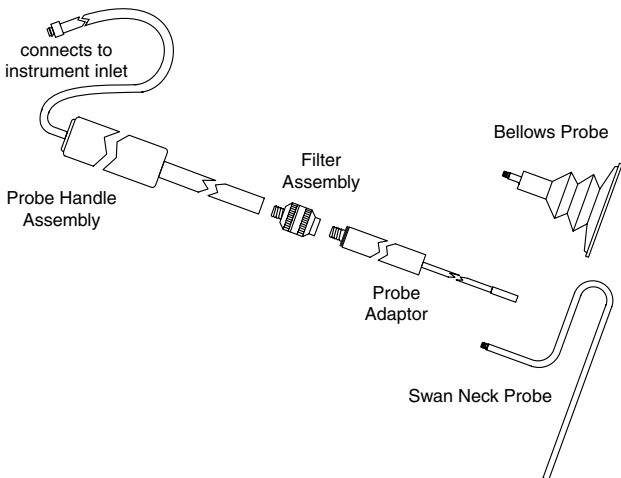

For examples of Swan Neck Probe / Bellows Probe and various other probe applications, see Appendix B, PROBE APPLICATIONS.

OPERATOR MAINTENANCE

Rechargeable Battery Pack

Three battery chargers are available from GMI, a Standard Charger, a Flatbed Charger and a Smart Charger.

Standard Charger

The GMI Standard Charger takes approximately 14 hours to charge a flat battery.



Flatbed Charger



The GMI Flatbed Charger allows the Leak Surveyor's battery pack to be charged in NORMAL mode, which takes approximately 14 hours to charge a flat battery. The Mode Select Switch can then be set to STAND-BY, where a trickle charge will maintain the battery in a fully charged state of readiness.

Smart Charger



The GMI Smart Charger provides both fast and standard charging facilities. It can charge an instrument and a spare battery pack simultaneously. Using the fast charge option, a battery pack can be 90% recharged in approximately 60 minutes and fully recharged in 120 minutes.

Replacing the Battery Pack

The following procedure should be carried out in a safe area:

- 1) Loosen the two instrument base screws (4mm hex) using the special tool provided and remove the battery cover.



- 2) Remove the battery pack.
- 3) Fit new battery pack.
- 4) Fasten base screws.

- 5) Check that instrument switches on and works to specification.

Recharging the Battery Pack

The battery pack should be recharged in the following situations:

The BAT or BAT FAULT message is displayed.

The instrument will not switch on.

The pump will not switch on.

It is recommended that the battery pack is fully discharged on a regular basis (once every three months). This can be done by running the instrument continuously or using the battery conditioning facility on the Smart Charger. The batteries can be charged on the instrument but the instrument itself should be switched off. Regular complete discharge will keep the battery pack in good condition.

Replacing Alkaline (LR20) Batteries

All four batteries should be replaced at any one time and in a safe area. GMI only recommend the use of Energiser or Duracell cells.

- 1) Loosen the two instrument base screws (4mm hex) using the special tool provided.



2) Remove battery cover.



3) Remove the old batteries.

4) Check battery compartment for damage to spring contacts or corrosion on springs.

Caution: Under no circumstances should rechargeable batteries be fitted in place of alkaline.

- 5) Insert four new batteries observing correct polarity indication in battery compartment base.
- 6) Replace battery cover and fasten base screws.
- 7) Check that the instrument switches on and works to specification.

Filter Replacement

Standard Probe Handle Assembly - Part No. 12481

Hydrophobic and cotton particulate filters in the probe handle minimise the danger of water and dust ingress.

Caution: The instrument should never be switched on without suitable filters installed.

If a blockage occurs the 'SAMPLE FAULT' indicator is displayed. Check the sample line and probe handle for blockage. Press Switch One () to clear the 'SAMPLE FAULT' message. Replace the filter(s) if the message does not clear.

To replace the filter(s), proceed as follows:

- 1) Unscrew the probe handle assembly.

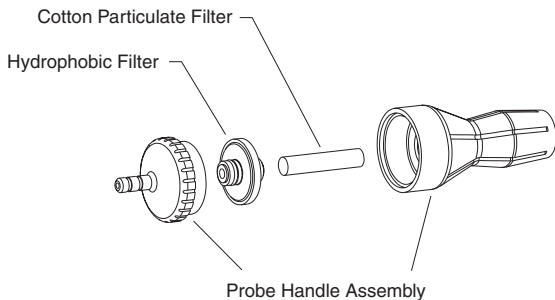

Figure 4.1 Filter Assembly

- 2) Remove the cotton particulate filter and discard.
- 3) Remove the hydrophobic filter.
- 4) Clean the probe handle to make sure that it is free from dirt and water.
- 5) Fit a new cotton particulate filter.
- 6) Fit the hydrophobic filter. The yellow label on the filter fits against the yellow label on the probe handle.
- 7) Reassemble the probe handle assembly.

Carpet Probe Assembly - Part No. 13535

A filter disc is installed in the sample collector filter housing to minimise the danger of dust ingress.

Caution: The instrument should never be switched on without suitable filters installed.

To replace the filter, proceed as follows:

- 1) Position the carpet probe with the sample collector upturned and filter washer visible, as shown in Figure 4.2.
- 2) Remove the screw that attaches the filter washer to the filter housing assembly. See Figure 4.3 illustrating exploded view of filter and housing assembly



Figure 4.2 Filter Assembly

- 3) Remove the dust filter, then discard.
- 4) Remove then clean the filter mesh to make sure that it is free from dirt.
Note: If the filter mesh is damaged or badly contaminated, a new filter mesh must be fitted.
- 5) Clean the filter housing.
- 6) Fit the filter mesh in the housing assembly.
- 7) Fit new dust filter.
- 8) Fit the filter washer and secure to the sample collector using the slotted screw.

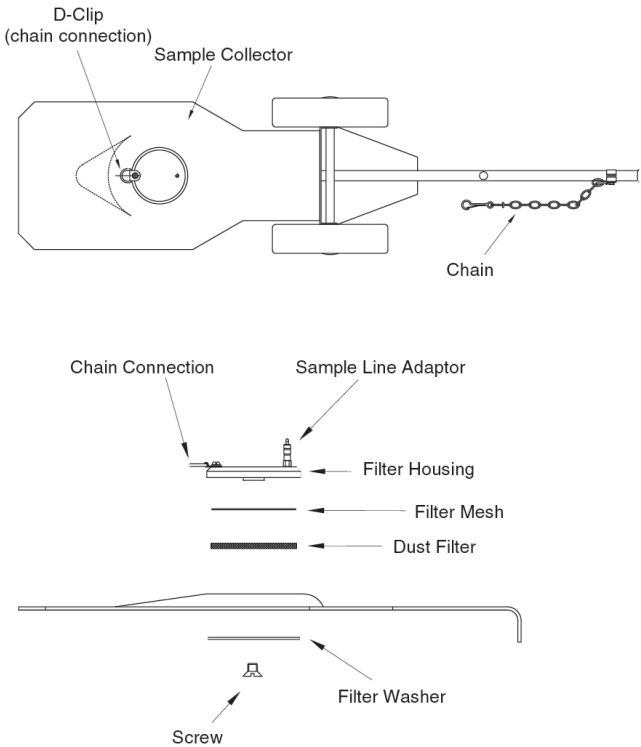

Figure 4.3 Carpet Probe Filter Assembly

Survey Probe Handle Assembly - Part No. 13561

Fitting of In-line filter assembly to the survey probe handle, as shown in Figure 4.4, will minimise the danger of water and / or dust ingress.

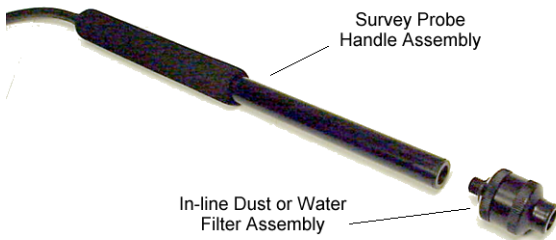



Figure 4.4 Survey Probe Handle and In-line Filter Assembly

Caution: The instrument should never be switched on without suitable filters installed.

If a blockage occurs the 'SAMPLE FAULT' indicator is displayed. Check the sample line and filter assembly for blockage. Press Switch One () to clear the 'SAMPLE FAULT' message. Replace the filter if the message does not clear.

In-line Water Filter

To replace the Hydrophobic Filter in the Water Filter Housing assembly, proceed as follows:

- 1) Unscrew the filter housing assembly (Figure 4.5).

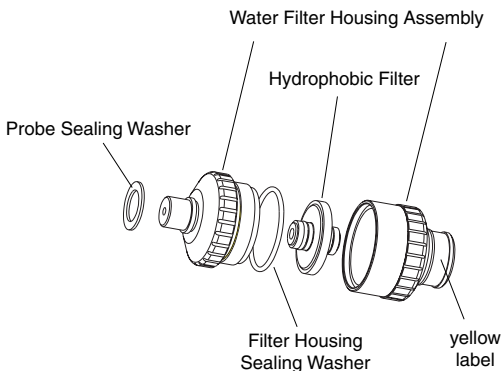

Figure 4.5 Water Filter Assembly

- 2) Remove Hydrophobic Filter, then discard.
- 3) Check Filter Housing Sealing Washer and Probe Sealing Washer for signs of damage or wear and replace if necessary.
- 4) Fit new Hydrophobic Filter.

Note: The filter should be installed with the yellow label on the filter, facing the yellow label on the housing flange.

- 5) Reassemble the Filter Housing assembly.

In-line Dust Filter

To replace the Dust Filter in the Dust Filter Housing assembly, proceed as follows:

- 1) Unscrew the filter housing assembly (Figure 4.6).

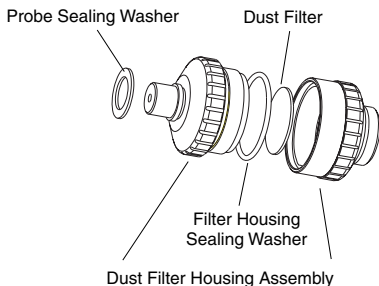

Figure 4.6 Dust Filter Assembly

- 2) Remove Dust Filter, then discard.
- 3) Check Filter Housing Sealing Washer and Probe Sealing Washer for signs of damage or wear and replace if necessary.
- 4) Fit new Dust Filter.
- 5) Reassemble the Filter Housing assembly.

CALIBRATION

The instrument has been calibrated for a particular flammable gas mixture. Where any doubt exists the instrument should be returned to GMI or an authorised distributor for calibration.

Three methods of calibration are possible:

- Manual Calibration. The instrument can be linked to a PC running GMI Manual Calibration software.
- Automatic Calibration. The GMI Auto Test Calibration System allows calibration without manually changing gas cylinders. The system links to a PC running GMI Workshop software.
- The GMI Instrument Management System (IMS) provides all the facilities of the Auto Test Calibration System with the added feature of instrument database management.

Note: The calibration systems above (hardware and software) are manufactured by GMI. For more details contact GMI or an authorised distributor.

Calibration Validity

Calibration validity is the responsibility of the user. Under normal operating conditions a 12 month period can be expected. This is no guarantee, however, as the precise application of the product is unknown to GMI. Individual codes of practice may dictate shorter periods.

Regular checking establishes a pattern of reliability and enables the calibration check period to be modified in line with operational experience. The higher the risk, the more frequently calibration should be checked.

ACCESSORIES



Accessories available for Leak Surveyor instrument

Part Number: **44512L / 44512LR**

Part Number	Description
-------------	-------------

42466	Standard Accessory Case (A)
-------	-----------------------------

12580	Gas Industry Survey Case (B)
-------	------------------------------

Note: An A or B suffix in the following list identifies the provision for that particular accessory in case A, case B, or both cases. Accessories without this identification can only be supplied as loose items.

12451	4mm Hex Driver (A ; B)
-------	------------------------

12370/2	Carrying Harness (A ; B)
---------	--------------------------

LEAK SURVEYOR - USER HANDBOOK

12481	Std. Probe Handle c/w Filters (A)
10077	Cotton Particulate Filters - Box of 10 (A ; B)
12480	Small Plastic Probe - Solid End (A)
or	
13427	Small Plastic Probe - Open End (A)
12393	Large Plastic Probe - Solid End
42400	Flexible Sampling Probe
13535	Carpet Probe
13595	Dust Filter (use with 13535)
13561	Survey Probe Handle Assembly (B)
13562	Survey Probe Adaptor Assembly (B) (use with 13561)
13563	Bellows Survey Probe (B)
13655	Swan Neck Survey Probe c/w Shroud (B)
42183	Water Filter Assy. c/w Filters (B) (use with 13561)
12358	Hydrophobic Filter (use with 12481 or 42183)
42184	Dust Filter Assy. c/w Filters (B) (use with 13561)
42388	Dust Filter - Box of 20 (use with 42184)
42235	Filter Housing Sealing washer (use with 42183 or 42184)
12379	Probe Sealing Washer (use with 42183 or 42184)
12712	Clear Sample Line x 1.5 metres (4ft 10ins.) approx. (A)
42207	User Handbook (A ; B)
13184	Standard Charger / 240V Power Supply (A)

13317	Standard Charger / 220V Power Supply (A)
13322	Standard Charger / 110V Power Supply (A)
42121	Flatbed Charger / 240V Power Supply
42122	Flatbed Charger / 220V Power Supply
42123	Flatbed Charger / 110V Power Supply
13100	Smart Charger c/w Data Logging 240V
13440	Smart Charger c/w Data Logging 220V
13340	Smart Charger c/w Data Logging 110V
13703	Manual Calibration Software (Windows)
42209	Calibration Overlay Card
13939	Instruction Sheet - Calibration Gases and Applications
42440	Comms Adaptor
13000	Spare Rechargeable Battery Pack

Note: For other sampling probes and accessories, contact GMI Ltd.

ADDITIONAL INFORMATION

Training

Training courses are available on all GMI products. Contact GMI Marketing Department for further details:

Tel: +44 (0) 141 812 3211

Fax: +44 (0) 141 812 7820

e-mail: sales@gmiuk.com

World Wide Web

Visit GMI web site at www.gmiuk.com

TYPICAL OPERATING PARAMETERS

Typical operating parameters are as follows:

Gas Range	Range	Resolution	Zero Stability	Accuracy
LEL	0 to 10% 10 to 100%	0.1% 1%	+/- 0.5% N/A	2% +/- 1% LEL
Volume Gas	0 to 100%	1%	+/- 2%	1% +/- 1% Gas
ppm	0 to 499 ppm 500 to 10000 ppm	1 ppm 10 ppm	5%	Typically 20%

Notes:

All the values above are at normal temperature and pressure.

Humidity is between 0% and 95% RH (non-condensing).

Pressure changes at the inlet and exhaust are minimised as they may cause transient changes in reading.

Size

180mm (7.08") x 95mm (3.74") x 105mm (4.13")

Weight

1.7kg (3.75lbs.) with alkaline batteries

Operating Temperature

-20° C to 50° C (-4° F to 122° F)

Humidity

0 – 95% RH

Construction

Moulded polypropylene case protected to IP54

Display

LCD containing:

Analogue display scaled 0-10, 0-100 or 0-10000

4 digit digital display

3 character range indication

Operational flags

Sampling System

Typical flow rates are as follows:

On (normal pump speed): 0.7 litres per minute

Hi (high pump speed): * 1.5 litres per minute

* Depending on battery voltage

Standard Probe and Handle assembly, Carpet Probe, Swan Neck or Bellows Probes using instrument integral pump with flow fail sensor. The sample path is protected by filters.

Note: Use of high speed pump will have an influence on battery life.

Power Source

4 'D' size alkaline cells providing approximately 21 hours runtime at 20° C (68° F) .

Rechargeble (NiCd) battery pack providing approximately 18 hours runtime at 20° C (68° F).

PROBE APPLICATIONS

Small Plastic (Solid End) Probe

This probe is available for the Leak Surveyor and is designed for use with barhole probing for below ground gas monitoring.



The solid end feature prevents blocking of the probe when detecting gas leaks in soft earth.

The Small Plastic Probe (Part No. 12480) is generally used with the Std. Probe Handle Assembly (Part No. 12481), incorporating both Cotton and Hydrophobic Filters to prevent the ingress of water or dirt. The Sample Line (Part No. 12712) connects the probe handle to the instrument and allows the pump to draw the sample into the instrument analysing chamber.

The probe is manufactured from a plastic material which is flexible and extremely robust. The probe's wall thickness provides the flexible strength to withstand bending around a 50cm radius or sustaining damage to, or collapse of, the sampling path if accidentally stood on, by the operator.

A longer plastic probe (Part No. 12393) is also available.

Note: Refer to Chapter 7 ACCESSORIES for other probes and accessories that can be used with this instrument.

Small Plastic (Open End) Probe

The Small Plastic Probe (Part No. 13427) is available for the Leak Surveyor and is designed for general, above ground, gas leak detection.

This probe generally used with the Std. Probe Handle Assembly (Part No. 12481), incorporating both Cotton and Hydrophobic Filters to prevent the ingress of water or dirt. The Sample Line (Part No. 12712) connects the probe handle to the instrument and allows the pump to draw the sample into the instrument analysing chamber.

The probe is manufactured from a plastic material which is flexible and extremely robust. The probe's wall thickness provides the flexible strength to withstand bending around a 50cm radius or sustaining damage to, or collapse of, the sampling path if accidentally stood on, by the operator.

Note: Refer to Chapter 7 ACCESSORIES for other probes and accessories that can be used with this instrument.

Carpet Probe

This probe is designed for use with the Leak Surveyor and is available as an accessory.



The Carpet Probe (Part No. 13535) draws a sample via the sample collector and through the Dust Filter (Part No. 13595). The sample line extends through the carpet probe handle and connects to the Leak Surveyor inlet. The instrument pump draws the sample into the analysing chamber. Selection of high speed pump setting provides

quicker detection of gas leaks via faster sample flow rate.

The Carpet Probe has a lightweight steel chassis with rubber tyres. The sample collector is manufactured from a flexible plastic material and, with the advantage of being mobile, maximises the efficiency of obtaining a sample from a roadway, monobloc/paved surface or similar type application.

Bellows Probe

This probe is also available as an accessory. The Bellows Probe (Part No. 13563) provides a method of obtaining more consistent readings by reducing the effect of wind and air dilution.



The Bellows Probe is of stainless steel construction housed in a flexible rubber boot. It is generally used with the Survey Probe Adaptor (Part No. 13562) which connects to the Survey Probe Handle Assembly (Part No. 13561). The Survey Probe Handle incorporates a sample line (Part No. 12712), which is connected to the instrument, and allows the pump to draw the sample into the instrument analysing chamber. Selection of high speed pump setting provides quicker detection of gas leaks via faster sample flow rate.

Note: This model of Survey Probe Handle does not incorporate an in-line filter. A Water Filter Assembly (Part No. 42183) or Dust Filter Assembly (Part No. 42184) is available and can be fitted as an accessory, if required. Refer to Chapter 7 ACCESSORIES.

Swan Neck Probe

This probe is also available as an accessory.



The Swan Neck Probe (Part No. 13565) has a number of small balanced holes in the probe length to give increased coverage in surveys. To prevent damage to the probe and provide an unrestricted sample path, a shroud assembly (Part No. 13655) is available. The shroud incorporates two skids which prevent probe contact with the ground surface. The Swan Neck Probe is of stainless steel construction

and is generally used with the Survey Probe Adaptor which connects to the Survey Probe Handle Assembly (Part No. 13561). The Survey Probe Handle incorporates a sample line which is connected to the instrument and allows the pump to draw the sample into the instrument analysing chamber. Selection of the high speed pump setting provides quicker detection of gas leaks via faster sample flow rate.

Note: This model of Survey Probe Handle does not incorporate an in-line filter. A Water Filter Assembly (Part No. 42183) or Dust Filter Assembly (Part No. 42184) is available and can be fitted as an accessory, if required. Refer to Chapter 7 ACCESSORIES.

OPERATING INSTRUCTIONS

The following multi-language instructions provide the user with a quick guide to the operation of the . .

 **Leak Surveyor** instrument.

Each language and pages reference is as follows:



- **English** - pages C-2 to C-5
- **Deutsch** (German) - pages C-6 to C-9
- **L'italiano** (Italian) - pages C-10 to C-13
- **Svensk** (Swedish) - pages C-14 to C-17
- **Dansk** (Danish) - pages C-18 to C-21
- **Nederlands** (Dutch) - pages C-22 to C-25

CHECKLIST

1. Check the instrument has no obvious faults.
2. Check accessories.
3. Read and understand handbook before use.
4. Switch ON
5. Check battery levels.
6. Check "ZERO" in fresh air.

SAFETY

- The instrument must be regularly serviced and calibrated by fully trained personnel in a safe area.
- Do not use instrument in potentially hazardous atmospheres containing greater than 21% Oxygen.
- Batteries (alkaline/rechargeable battery pack) must be exchanged in a safe area.
- The rechargeable battery pack must only be recharged in a safe area.
- Never use damaged batteries.
- Make sure that the batteries are fitted correctly before use.
- Never expose the batteries or instrument to extreme heat.
- Only GMI replacement parts should be used.
- If the instrument detects gas, follow your own organisation's procedures and operational guidelines.
- The combustion chamber is a flameproof assembly and must not be opened in the presence of a flammable atmosphere.
- Gas can be dangerous and care should always be taken in its use.
- Leak Surveyor instrument is certified as: EEx iad IIB T3 (-20°C ≤ Tamb ≤ 50°C).

BAS03ATEX2448X   II 2 G.



UL 913 Class 1 Groups C and D.

- This equipment is designed and manufactured to protect against other hazards as defined in paragraph 1.2.7 of Annex II of the ATEX Directive 94/9/EC

Any right of claim relating to product liability or consequential damage to any third party against GMI is removed if the safety warnings are not observed.

AREAS OF USE

Exposure to certain chemicals can result in a loss of sensitivity of the flammable sensor. Where such environments are known or suspected it is recommended that more frequent response checks are carried out. The chemical compounds that can cause loss of sensitivity include Silicones, Lead, Halogens and Sulphur. Do not use instrument in potentially hazardous atmospheres containing greater than 21% Oxygen. The enclosure material is polypropylene and must not be exposed to environments, which are liable to result in mechanical or thermal degradation or in damage caused by contact with aggressive substances. Additional protection may be required in environments where the instrument enclosure is liable to be damaged.

OPERATOR MESSAGES / FAULT FLAGS

Various messages can appear on the LCD screen to indicate instrument status.

'SAMPLE' Indication that the pump is running and the instrument is sampling.

'OFF' Indication that the instrument is about to switch off. This command can be cancelled by a single press of any switch.

'SAMPLE FAULT' Indication of a problem with the instrument's flow due to the sample path being blocked, water ingress, a blocked filter or pump failure. This may also indicate a fault with the instrument's flow fail detection circuitry. The instrument will alarm and the pump will stop. The sample path should be checked and Switch One pressed to clear sample fault and re-start the pump.

'CHECK ZERO' Indication that there may have been a zero shift due to the presence of gas. Switch off the instrument and switch on again in fresh air.

'ZERO FAULT' Indication that the zero is outwith its calibration limits. Switch the instrument off and then on again in fresh air. If the fault does not clear, return the instrument for servicing.

'BAT' Indication that the batteries will soon require replacement. At this point there will be approximately 1 to 2 hours left in a set of alkaline batteries, although this figure will vary depending on battery manufacturer, temperature conditions, usage etc. With rechargeable batteries the 'BAT' flag indicates approximately 30 minutes operation left.

As the battery power continues to fall, the LCD flashes a 'BAT FAULT' message. Subsequently the LCD displays 'OFF' and the instrument automatically switches off. The batteries should be replaced immediately.

'BAT FAULT' Indication that the batteries should be replaced immediately.

'EEEE' Indication that the measurement in the ppm (semiconductor sensor) range rises above 9999 (instrument over range).

'1' Indication, during power on, that a calibration data error has been detected. The instrument should be returned for servicing.

OPERATION

Switch ON

Press and Hold Switch One

, to switch instrument and pump On. This initiates the instrument's warm-up cycle.

SWITCH 1

SWITCH 2

SWITCH 3

SWITCH 4



All LCD segments are displayed:

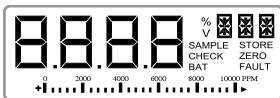

followed by Instrument Type and Software version,



then Battery status, as shown:



Next the LEL alarm level alternates between LEL and HI.

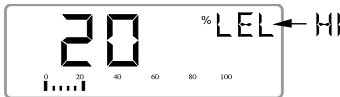

Next the instrument indicates, as month and year, when the next calibration is due.

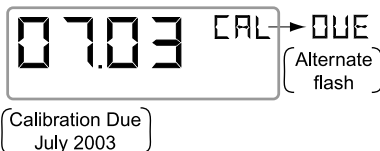

This display screen is followed by the current gas detection reading.

Pump Speed On / Hi / Off

A single press of Switch One  when the pump is running selects high pump speed (increasing flow rate). A further press turns the pump off and stops sampling. Pressing switch one again turns the pump back on at normal speed.

Change Range

Each single press of Switch Two  changes the range. The display cycles through the available ranges in the order: PPM - LEL - PPM - etc. Note: The instrument auto-ranges between LEL and Volume Gas.

Zero PPM Range

When ppm range is selected, a double press of Switch Three  is required to zero range, and should be carried out in fresh air.

Clearing Alarms

A double press of Switch Four  acknowledges the alarm for 60 seconds if non-latching.

Enable / Disable Audible 'Geiger' Alarm

When in PPM gas detection range, a single press of Switch Four  will activate the audible Geiger indication.

When enabled, the display changes between PPM and Aud:

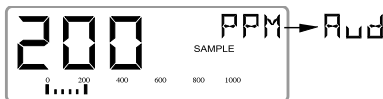

A further press of Switch Four  mutes the indication.

Switch OFF



A double press of Switch One  turns the instrument Off. There is a five second shutdown sequence during which time, OFF is displayed. To abort shutdown, press any one of the four instrument switches.

Pruefliste

1. Gerat auf sichtbare Beschadigungen pruefen
2. Zubehoer ueberpruefen
3. Vor der Inbetriebnahme das Handbuch lesen, oder mit der Handhabung des Instrument's vertraut sein
4. Gerat einschalten und laut Anleitung ueberpruefen
5. Batterieanzeige ueberpruefen
6. Nullpunkt in frischer Luft ueberpruefen

Sicherheitshinweise

- Das Instrument muss regelmassig gewartet und durch Fachpersonal kalibriert werden
- Alkali oder wiederaufladbare Batterien duerfen nur in Ex freier Zone gewechselt oder aufgeladen werden. Sichere efestigung vor Gebrauch pruefen
- Keine beschadigten Batterien verwenden, und grosse Hitzeeinwirkungen auf die Batterien vermeiden
- Nur Original GMI Ersatzteile verwenden
- Beim Auftreten von Gas, die jeweils gueltigen Vorschriften befolgen
- Gas kann gefaehrlich sein, und ist daher mit Vorsicht zu behandeln
- Die Messkammer ist flammensicher ausgefuehrt und darf nicht in Ex Zonen geoeffnet werden
- Leak Surveyor Instrumente sind zertifiziert nach: EEx iad IIB T3 (-20°C ≤ bis ≤ 50°C).

BAS03ATEX2448X   II 2 G.



UL 913 Klasse 1 Gruppe C und D.

- Das Instrument ist zur geeignet zur Verwendung nach Paragraph 1.2.7 Anh.II ATEX 94/9/EC

Alle Haftungsansprueche gegenueber GMI entfallen, wenn die Sicherheitshinweise nicht beachtet werden

Verwendungsgebiete

Das auftreten von verschiedenen Chemikalien kann die Empfindlichkeit des Sensors fuer brennbare Gase beeinflussen. Beim vorhandensein dieser Stoffe ist ein kuerzeres Serviceintervall erforderlich. Folgende Komponenten fuehren zur verringering der Sensorempfindlichkeit: Silicone, Halogene und Schwefel. Das Instrument darf nicht in Athmosphaeren mit mehr als 21% Sauerstoff verwendet werden. Im Gehaeuseaufbau sind Polypropylenzusaeetze enthalten, es sind daher Umgebungen,welche zu mechanischen BeschaeDIGungen fuehren und Waerme enthalten zu vermeiden. Weiters ist das Instrument vor BeschaeDIGungen zu schuetzen.

Betriebshinweise /Stoerungsmeldungen

Verschiedene Anzeigen am Display geben den Geraetestatus an

'SAMPLE' Pumpe laeuft und Messung erfolgt.

'OFF' Instrument im Abschaltmodus, 1x Druecken einer beliebigen Taste unterbricht diesen Vorgang

'SAMPLE FAULT' Probenleitung,Filter oder Pumpe verlegt, ev.Wassereintritt, Pumpenstop automatisch, Filter, Leitung etc. pruefen. Mit Taste 1 Pumpe wieder starten.

'CHECK ZERO' Nullpunktdrift durch Einschalten in nicht gasfreier Umgebung. Geraet Ausschalten und wieder Einschalten in Frischluft

'ZERO FAULT' Nullpunkt ausserhalb der limitierten Werte. Geraet Ausschalten u. wieder Einschalten. in Frischluft, wenn der Fehler bleibt, Geraet zum Service geben

'BAT' Batterien sollen bald gewechselt werden.

Betrieb max.60 min. mit Alkaline Batterien abhaengig vom Hersteller, Verwendung,Temperatur etc.

Betrieb max.30 min. mit aufladbaren Batterien. Wenn die Batteriespannung laufend absinkt, blinkt

'BATFAULT' im Display, anschliessend erscheint OFF und das Geraet schaltet ab. Batteriewechsel erforderlich.

'BAT FAULT' Batteriewechsel erforderlich

'EEE' Messung im ppm Modus (Halbleitersensor) ueber 9999 (Bereichsueberschreitung)

'1' Kalibrierfehler. Geraet zum Service

Bedienung

Einschalten

Taste 1  Druecken und Halten, Gerat und Pumpe ein und die Selbsttestphase beginnt.

TASTE 1

TASTE 2

TASTE 3

TASTE 4

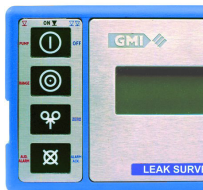

Alle LCD Segmente werden kurz dargestellt,

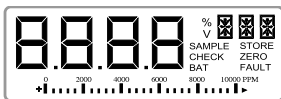

die Instrument Type, Softwareversion



und der Batteriezustand,



Die LEL Alarmanzeige wechselt zwischen LEL und HI

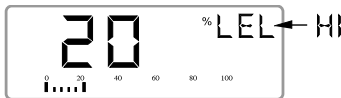

Anzeige der naechst faelligen Kalibrierung mit Monat und Jahr (Calibration due July 2003) blinkend

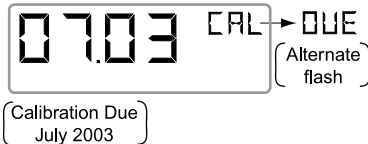

Weiters wird das Kalibriergas angezeigt.

Pumpendrehzahl Ein/Hoch/Aus

Taste 1  1x Druecken bei laufender Pumpe erhoeht die Pumprate, ein weiterer Druck stoppt die Pumpe und die Probenahme. Erneutes Druecken startet die Pumpe wieder mit Normaldrehzahl.

Messbereichswechsel

Taste 2  1x Druecken wechselt den Messbereich

Im Display wechselt folgende Anzeige PPM – LEL – PPM – etc.

Hinweis: automatische Umschaltung von LEL auf Volume Gas (Vol%)

Nullpunkt PPM Bereich

Taste 3  2x Druecken setzt den Nullpunkt im ppm Bereich. Nur in Frischluft durchfuehren.

Alarmquittierung

Taste 4  2x Druecken quittiert den Alarm fuer 60 sec. bei der Alarmkonfiguration -nicht selbsthaltend-

Geiger Signal Ein / Aus

Taste 4  im ppm Bereich 1x Druecken aktiviert das akustische Geigersignal und die Anzeige im Display wechselt zwischen PPM und Aud.

Erneutes Druecken von

Taste 4  schaltet das Geigersignal aus

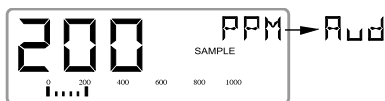

Ausschalten



Taste 1  2x Druecken

PRIMA DELL'USO

1. Verificare che lo strumento non abbia dei guasti.
2. Verificare gli accessori.
3. Leggere il manuale d'uso.
4. Accendere lo strumento
5. Verifica della carica delle batterie.
6. Verificare lo ZERO in aria fresca.

SICUREZZA

- Lo strumento deve essere regolarmente calibrato in area sicura da personale istruito.
- Non usare lo strumento in una area potenzialmente pericolosa contenente una percentuale di ossigeno maggiore del 21%.
- Le batterie (Alkaline/pacco ricaricabile) devono essere sostituite in un'area sicura.
- Ricaricare il pacco batteria solo con il ricaricatore GMI in una area sicura.
- Non utilizzare batterie danneggiate.
- Assicurarsi che le batterie sia fissate correttamente prima dell'uso.
- Non esporre le batterie o lo strumento ad alta temperatura.
- Utilizzare solamente i ricambi GMI.
- Se lo strumento rivelasse del gas, seguire le procedure organizzative e le indicazioni operative del caso.
- La camera di combustione è a prova di fiamma e non deve essere aperta in presenza di gas infiammabile nell'atmosfera.
- Il gas può essere pericoloso, si dovrebbe sempre averne cura nell'uso.
- Il Leak Surveyor è uno strumento certificato con: EEx iad IIB T3 (-20°C ≤ Tamb ≤ 50°C).

BAS03ATEX2448X   II 2 G.



UL 913 Class 1 Groups C and D.

- Questo equipaggiamento è progettato e costruito per essere protetto contro altri pericoli come descritto nel paragrafo 1.2.7 of Annex II of the ATEX Directive 94/9/EC

Ogni diritto di reclamo, relativo alla responsabilità del prodotto o a danni verso terzi, contro GMI non è da considerarsi valido se non vengono osservate le norme di sicurezza.

AREE D'USO

L'esposizione ad agenti chimici condiziona la sensibilità del sensore del gas. Quando tali ambienti sono conosciuti o sospettati è raccomandabile una verifica più frequente della misura. I componenti che possono causare la perdita di sensibilità sono a base di silicone, piombo, alogeni e solfuri. Lo strumento non deve essere usato in una area potenzialmente pericolosa contenente più del 21% di Ossigeno. La scocca è in polipropilene, non deve essere esposta in ambienti che possono essere responsabili di una degradazione meccanica, termica o a contatto di sostanze corrosive. Un'addizionale protezione può essere richiesta, in ambienti dove lo strumento debba includere la possibilità di essere danneggiato.

MESSAGGI OPERATIVI/GUASTO

Vari messaggi possono comparire sul display dello strumento per indicarne lo stato.

'SAMPLE' Indica che la pompa è in funzione, quindi lo strumento sta campionando.

'OFF' Indica la fase di spegnimento. Il comando può essere interrotto premendo un qualsiasi pulsante sulla tastiera.

'SAMPLE FAULT' Indica un problema con il flusso dell'aria campionata dovuto a una ostruzione della linea di campionamento, all'ingresso d'acqua, al filo in cotone intasato oppure ad un guasto sulla pompa. Può anche indicare un problema al circuito del sensore di flusso. Lo strumento visualizza il guasto e blocca la pompa. Verificare la linea di campionamento e riavviare la pompa con il primo pulsante per cancellare il guasto.

'CHECK ZERO' Indica che potrebbe esserci uno spostamento dello zero, dovuto alla presenza di gas. Spegnerne e riaccendere lo strumento in aria fresca.

'ZERO FAULT' Indica che lo zero è fuori calibrazione. Lo strumento deve essere spento e riacceso in aria fresca. Se il guasto permane inviarlo al Servizio Assistenza..

'BAT' Indica che le batterie dovrebbero al più presto essere sostituite. A questo punto potranno approssimativamente durare 1-2 ore per le batterie Alkaline, benchè questa condizione dipenda dal fabbricante, dalle condizioni ambientali ecc. Con la batteria ricaricabile il messaggio BAT indica invece circa 30 minuti di autonomia.

Quando la carica della batteria è insufficiente, il display visualizza il messaggio FAULT BAT. Successivamente la pompa si spegne e compare la scritta OFF, lo strumento si spegne in automatico. Le batterie devono essere sostituite.

'BAT FAULT' Indica che le batterie vanno sostituite immediatamente.

'EEEE' Indica che la scala del ppm (sensore a semoconduttore) viene superata, cioè il valore è arrivato sino al fondo scala (9999ppm)

'1' Questo messaggio, che può apparire durante la fase d'accensione, indica che è stato rilevato un errore di calibrazione. Inviare lo strumento al Servizio Assistenza.

OPERAZIONI

Accensione

Tenere premuto il pulsante 1



lo strumento e la pompa si accendono.

Questo darà inizio al ciclo di riscaldamento.

Tutti i segmenti del LCD si illuminano:

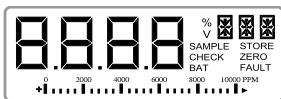

segue il tipo di strumento e la versione Software,



viene visualizzato lo stato delle batterie.



Poi il livello dell'allarme LEL alternativamente tra LEL e HI.

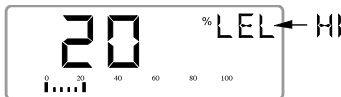

Dopo lo strumento indica, mese e anno, della prossima calibrazione.

(Prossima calibrazione Luglio 2003)

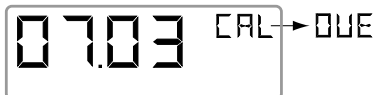

Quindi il display segue con la lettura corrente del gas.

PULSANTE 1

PULSANTE 2

PULSANTE 3

PULSANTE 4



Pompa accesa/alta aspirazione/spenta

Premendo una volta il pulsante 1  quando la pompa è in funzione, si attiva la seconda velocità della pompa (incrementando il flusso). Un'ulteriore pressione spegne la pompa. Premendo ancora una volta, la pompa si attiva nella modalità di normale aspirazione.

Cambio di Scala

Ogni pressione del pulsante 2  cambia la scala. Il display visualizza le scale in questo ordine: PPM – LEL – PPM - ecc.

Nota: Il cambio di scala tra LEL e Volume GAS è automatico.

Azzerare la scala del PPM

Quando la scala del PPM è attiva, una doppia pressione sul pulsante 3  azzerà la scala, si dovrebbe portare lo strumento in un ambiente con aria fresca.

Acquisizione degli Allarmi

Una doppia pressione del pulsante 4  acquisisce l'allarme per 60 secondi se è in modalità non-latching.

Attivare/Disattivare l'Allarme Sonoro Geiger

Quando la rivelazione è sul PPM, una singola pressione sul pulsante 4  attiverà l'allarme sonoro tipo Geiger.

Quando è attivo, il display visualizza ad intermittenza PPM e Aud:

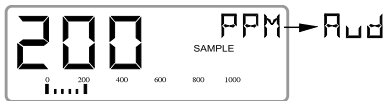

Un'ulteriore pressione del pulsante 4  disattiverà l'allarme sonoro.

Spegnimento



Una doppia pressione del pulsante 1  spegne lo strumento. Ci sono 5 secondi per la sequenza di spegnimento, il display visualizza la scritta OFF. Per interrompere la sequenza, basta la pressione di un qualsiasi pulsante della tastiera.

CHECKLISTA

1. Kontrollera att instrumentet ej har några synliga fel.
2. Kontrollera samtliga tillbehör.
3. Läs och förstå instruktionsboken innan Du använder instrumentet
4. Slå på instrumentet
5. Kontrollera batteriets kapacitet.
6. Kontrollera "Nollan" I frisk luft.

SÄKERHET

- Instrumentet skall regelbundet kontrolleras och kalibreras av kunnig personal I härför avsedd miljö.
- Instrumentet får ej användas i utrymmen där syrehalten överstiger 21 vol%.
- **Batterier:** Alkaline batterier eller *Laddningsbara batteripaket måste laddas eller bytas utanför Ex-klassat område och monteras på rätt sätt.
- Använd aldrig skadat batteri. Det får ej heller utsättas för höga temperaturer.
- Endast GMI-orginaldelar får användas.
- Om instrumentet reagerar för gas skall Ert företags normala rutiner följas.
- Mätkammaren för brännbar gas är en Ex-klassad enhet och får ej öppnas då risk för sådan gas föreligger.
- Leaksurveyor -instrument är klassat enligt EEx iad IIB T3 (-20°C ≤ Tamb ≤ 50°C).

BAS03ATEX2448X   II 2 G.



"UL 913 Class 1 Groups C and D".

- Denna utrustning är konstruerad och tillverkad för att skydda mot andra risker än definitionen I paragraf 1.2.7 i Annex II i ATEX Direktivet 94/9/EC

All rätt till skadestånd med hänvisning till produktansvar eller skada hos tredje man gentemot GMI upphör om denna varning ej beaktas.

ANVÄNDNINGSSOMRÅDE

Exponering för vissa kemikalier kan resultera I att sensorn för brännbara gaser skadas. I sådan atmosfär rekommenderas att ofta kontrollera instrumentets känslighet. De kemiska substanser som kan orsaka försämrade reaktion är bl.a. Silikoner, Bly, Halogener and Sulfider. Använd inte instrumentet där syrehalten kan överskrida 21vol%. Instrumenthuset är

tillverkat av polypropylen och får ej utsättas för eller komma i kontakt med vissa kemikalier. En ytterligare skyddsväska kan vara nödvändigt då instrumentet används i speciella miljöer.

MEDELANDEN / TECKEN I DISPLAYEN

Olika besked visas i displayen för att indikera instrumentets status.

'SAMPLE' Betyder att pumpen går och instrumentet suger.

'OFF' Betyder att instrumentet håller på att stängas av. Detta kommando kan avbrytas genom att trycka på någon knapp.

'SAMPLE FAULT' Betyder att flödet inte är korrekt. Detta kan bero på att sondslangen är blockerad, vätska har sugits in i instrumentet, filtret är igensatt eller fel på pumpen. När instrumentet körs i CSM-läge larmar instrumentet och pumpen fortsätter att gå. Kontrollera och rengör provtagningsutrustningen (sondslangar, filter etc.).

I CGI-läge stannar pumpen automatiskt. Efter att felet åtgärdats kan pumpen återstartas genom att trycka på knapp "1".

'CHECK ZERO' Betyder att nolljusteringen ej kunnat utföras på grund av närvaro av gas. Stäng av instrumentet och återstarta det i ren luft..

'ZERO FAULT' Betyder att "nollan" ligger utanför sin gräns. Stäng av instrumentet och återstarta det i ren luft. Om felet ej försvinner lämnas instrumentet för service till kvalificerad personal.

'BAT' Betyder att batteriet snart behöver bytas. Då detta meddelande visas är den återstående drifttiden med alkalinebatterier ca. 60 minuter. Denna tid kan dock variera mycket beroende på fabrikat, temperatur m.m.

Med laddningsbart batteri visas 'BAT' när det återstår ca. 30 minuter.

Vartefter batterispänningen fortsätter att sjunka blinker 'BAT FAULT'. Slutligen visas 'OFF' och instrumentet stänger av sig automatiskt.

Batteriet skall omedelbart bytas eller laddas.

'BAT FAULT' Betyder att batteriet skall bytas omedelbart.

'EEEE' Betyder att vid mätning av brännbara gaser i läcksökning-området eller kolmonoxid är koncentrationen mer än 999 ppm (mätområdet överskridet). I ppm-läget växlar instrumentet automatiskt till % LEL – vol% även om detta inte visas. Denna indikering syns även om mätaren går under -99 (felaktig nollpunkt) vid mätning av kolmonoxid.

'1' Betyder även efter att instrumentet satts i gång att informationen angående kalibrering är felaktig Instrumentet skall lämnas för service.

BRUKSANVISNING

Slå på

Tryck och håll nere knapp "1"

 för att sätta på instrumentet och pumpen. Detta startar en automatisk kontroll och uppvärmning av instrumentet:

Alla tecken visas i displayen

och åtföljs av Instrumentets beteckning, mjukvaruversion

och batteristatus.

Därefter visas larmnivåerna LÅG/HÖG följt av datumet för nästa kalibrering.

KNAPP 1

KNAPP 2

KNAPP 3

KNAPP 4

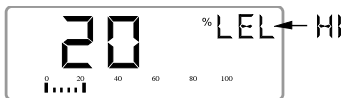

(Calibration Due
July 2003)

Dessa meddelande följs av den aktuella gaskoncentrationen.

Pumphastigheten

Ett tryck på knapp "1"  då pumpen går ökar hastigheten till forserat flöde. Ytterligare ett tryck på knapp "1" stänger av pumpen. Vid nästa tryck på knapp "1" startar åter pumpen i normaldrift.

Displayen går igenom områdena enligt %LEL / vol%Gas – Oxygen – Kolmonoxid – %LEL / vol%Gas etc.

Byte av mätområde

Ett tryck på knapp "2"  ändrar mätområdet

Displayen går igenom områdena enligt PPM / %LEL / PPM etc.

Anm. Instrumentet går automatiskt över från %LEL till vol% gas.

Nollställ ppm

När detta läge valts dubbeltryck på knapp "3"  för att nollställa mätområdet (måste utföras i ren luft)

Kvittering av larm (endast i CSM-läge)

Dubbeltryck på knapp "4"  kvitterar larm under 60 sek.

Aktivering av "Tick-Tack" (Geiger-funktion)

För att aktivera "Geigerfunktionen" (i PPM-läge) tryck ner knapp "4" . Då det är möjligt växlar displayen mellan PPM och Aud.

Med ytterligare ett ryck stängs funktionen av.

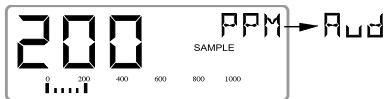

Stäng av



Ett dubbeltryck på knapp "1"  stänger av instrumentet. ("Off" visas i displayen och instrumentet går igenom en "avstängningssekvens" under 5 sek.). För att avbryta denna tryck på någon av knapparna 1-4.

Tjek liste

1. Tjek at instrumentet ikke har nogle åbenlyse fejl.
2. Tjek tilbehør.
3. Læs og forstå bruger manualen før brug.
4. Tænd instrumentet
5. Tjek batteriet level.
6. Tænd altid og nulstil i frisk luft.

Sikkerhed

- Instrumentet skal regelmæssigt serviceres og kalibreres af autoriseret personale.
- Opladning af batterier skal ske i et sikkert rum.
- Tjek batteriet sidder rigtigt fast på instrumentet før brug.
- Udsæt aldrig batteri eller instrumentet for ekstrem varme.
- Brug kun GMI reserve dele til instrumentet.
- Hvis instrumentet konstaterer gas, følg da de procedure som din organisation har foreskrevet.
- Forbrændings kammer er brandsikker tilbehør, og må ikke åbnes i almindelig atmosfære.
- Ethvert krav i forbindelse med produkt ansvar eller følge skade på tredje part imod GMI, er fjernet hvis de ovenstående forskrifter ikke håndhæves.
- LEAK SURVEYOR instrument er certificeret ifølge: EEx iad IIB T3 (-20°C ≤ Tamb ≤ 50°C).

BAS03ATEX2448X   II 2 G.



UL 913 Class 1 Groups C and D.

Bruger områder

Afdækning af bestemte kemikalier kan resultere i tab af følsomheden i LEL sensoren. Hvor disse omgivelser er kendte eller mistænkt, anbefales det at foretage målinger oftere. Den kemiske sammensætning som kan resultere i tab af følsomhed, inkludere silikoner, bly, halogen og svovl. Brug ikke instrumentet ved potentiel farlig atmosfære, der indeholder mere end 21 % ilt.

Bruger beskeder og fejl

Forskellige beskeder/tegn forekomme på displayet under brug.

'SAMPLE' fortæller at pumpen kører, og at instrumentet optager prøver.

'OFF' Indikerer at instrumentet er ved at slukke. Denne kommando kan afbrydes ved et tryk på en anden knap.

'SAMPLE FAULT' Fortæller at der er et problem under prøve sugning, som kan være følgende: opsugning af skidt, vand, filter blokering eller eb fejl i pumpen. Under måling og "purge" stopper pumpen automatisk. Tjek for disse fejl, og tryk på knap 1 for at genstarte pumpen.

'CHECK ZERO' Indikerer at der måske har været en fejl under måling. Sluk instrumentet og tænd igen i frisk luft.

'ZERO FAULT' Indikerer at nul grænsen er uden for kalibrerings området. Sluk instrumentet og tænd igen i frisk luft. Hvis fejlen ikke er væk, send instrumentet til service.

'BAT' Fortæller at batteriet snart løber tør for strøm. Alt efter kvaliteten at Alkaline batterier, vil der ca. vil være 60 minutter tilbage. Med genopladelige batterier er der ca. 30 minutter tilbage. Efter strømmen her fra falder, begynder 'BAT FAULT' at blikke. Efter noget tid slukkes instrumentet automatisk.

'BAT FAULT' Fortæller at batteriet straks skal skiftes.

'EEEE' Indikerer at målingen af PPM er oversteget 9999 (som er højeste måling).

'1' Kan fremkomme efter opstart, betyder at der er en kalibrering fejl. Instrumentet skal sendes til service.

Bruger muligheder

KNAP 1

KNAP 2

KNAP 3

KNAP 4



Tænd for instrumentet

Tryk og hold nede den knap 1

, så startes opvarmnings processen og pumpen.

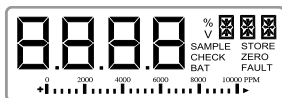

Under opvarmning identificeres model, serienummer, software version,



batteristatus,



kalibrerings måned og år.

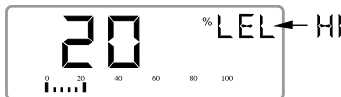

Herefter vil displayet begynde at vise målinger.



(Calibration Due
July 2003)

Pumpe

Et tryk på knap 1 , når pumpen kører, og pumpen går på high. Et tryk mere på knap 1 stopper pumpen.

Et tryk mere på knap 1, og pumpen er tilbage til normal.

Skift måling

Hvert tryk på knap 2 , skifter måling. Følgende er mulig: PPM – LEL – PPM, ect.

Instrumentet skifter selv mellem LEL og Volume gas

Nulstil PPM måling

Når PPM måling er valgt, tryk 2 gange på knap 3 , til den nulstiller. (Bør gøres i frisk luft)

Slukning af alarm

2 tryk på knap 4 , stopper alarmen i 60 sekunder, hvis den er non latching.

Aktivere hørlig geiger

Ved PPM måling, et tryk på knap 4 , vil aktivere hørlig geiger.

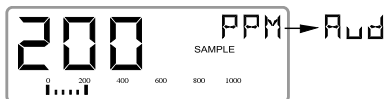

Et tryk mere på knap 4 , for at afbryde igen.

Sluk instrumentet



Tryk 2 gange på knap 1 .

CHECKLIST

1. Kijk na of het instrument geen zichtbare fouten vertoont.
2. Kijk de accessoires na.
3. Lees en begrijp het handboek voor gebruik.
4. Schakel het toestel aan
5. Kijk het batterijniveau na.
6. Controleer "NUL" in open lucht.

VEILIGHEID

- De instrumenten moeten regelmatig nagekeken en gekalibreerd worden door daartoe opgeleid personeel in een veilig lokaal.
- Gebruik het instrument niet in een schadelijke atmosfeer met meer dan 21 % zuurstof.
- Batterijen (alkaline batterijen/herlaadbare batterijen) moeten vervangen en heropgeladen worden in een veilige omgeving.
- De batterijen moeten precies passen voor gebruik. Gebruik nooit beschadigde batterijen of stel ze niet aan extreme hitte bloot.
- Alleen GMI wisselstukken mogen gebruikt worden.
- Indien het instrument gas detecteert, volg dan uw eigen bedrijfsprocedure en gebruiksaanwijzing.
- De verbrandingskamer is een brandvrij onderdeel en mag niet geopend worden in een ontlambare atmosfeer.
- Gas kan gevaarlijk zijn en daarom moet men bij gebruik ervan altijd voorzichtig zijn.
- Leak Surveyor instrumenten zijn gecertificeerd zoals: EEx iad IIB T3 (-20°C ≤ Tamb ≤ 50°C).

BAS03ATEX2448X   II 2 G.



UL 913 Klasse 1 Groepen C en D.

- Dit toestel is ontwikkeld en gemaakt om ons te beschermen tegen voorvallen zoals beschreven in paragraaf 1.2.7 van Annex II van de ATEX 94/9/EC

Elke recht op een claim met betrekking tot de betrouwbaarheid of de daardoor veroorzaakte schade van welke derde partij dan ook aan GMI zal verworpen worden indien de waarschuwingen genegeerd zijn.

PLAATSEN VAN GEBRUIK

Blootstelling aan bepaalde chemicaliën kan resulteren in een verlies van gevoeligheid van de brandsensor. Indien deze omgevingen bekend zijn of vermoed worden, is het aanbevolen om meer frequente check-ups uit te

voeren. Chemische stoffen die een verlies van gevoeligheid kunnen veroorzaken zijn siliconen, lood, halogenen en zwavel. Gebruik het instrument niet in een schadelijke atmosfeer met meer dan 21 % zuurstof. Het omhullende materiaal is polypropyleen en dit mag niet blootgesteld worden aan omgevingen die waarschijnlijk resulteren in mechanische of thermische degradatie of schade veroorzaakt door contact met agressieve substanties. Bijkomende bescherming kan nodig zijn in omgevingen waar het omhulsel van het instrument onderhevig kan zijn aan schade.

GEBRUIKSBOODSCHAPPEN / FOUTMELDINGEN

Verschillende boodschappen kunnen op het LCD scherm verschijnen om de status van het instrument aan te duiden.

'SAMPLE' Indicatie dat de pomp draait en dat het instrument meet.

'OFF' Indicatie dat het instrument bijna gaat uitschakelen. Dit kan geannuleerd worden door een enkele druk op eendert welke knop.

'SAMPLE FAULT' Indicatie van een probleem met de instroom van het instrument doordat de invoer geblokkeerd is, door waterinsijpeling, een verstopte filter of falen van de pomp. Dit kan ook op een fout in het invoer detectie circuit van het instrument duiden. Het instrument geeft alarm en de pomp stopt. De invoer, filters etc. moeten gecontroleerd worden op waterinsijpeling of verstopping en knop één moet dan ingedruwd worden om de pomp te herstarten.

'CHECK ZERO' Indicatie dat het nulpunt gewijzigd kan zijn door de aanwezigheid van gas. Schakel het instrument uit en opnieuw aan in frisse lucht.

'ZERO FAULT' Indicatie dat het nulpunt buiten de kalibratielimiëten valt. Schakel het instrument uit en opnieuw aan in frisse lucht. Indien de foutmelding niet verdwijnt, breng het toestel terug voor onderhoud.

'BAT' Indicatie dat de batterijen weldra aan vervanging toe zijn. Nu resten er nog ongeveer 1 à 2 uur met alkaline batterijen, alhoewel dit erg afhankelijk is van de batterijenproducent, temperatuur, gebruik etc. Met herlaadbare batterijen duidt 'BAT' nog ongeveer 30 minuten resterende gebruiksduur aan. Naarmate de batterijkraft daalt, knippert op het LCD scherm 'BAT FAULT'. Daarna zal de LCD automatisch 'OFF' vertonen en schakelt het toestel zelf uit. De batterijen moeten dan onmiddellijk vervangen worden.

'BAT FAULT' Indicatie dat de batterijen onmiddellijk moeten vervangen worden.

'EEEE' Indicatie dat de meting in het ppm (semiconductor sensor) bereik boven 9999 is gestegen (instrument buiten bereik).

'1' Indicatie, die ook na aanschakelen van de stroom kan verschijnen, dat een kalibratiegegevensfout werd opgespoord. Het instrument moet binnen voor onderhoud.

GEBRUIK

Schakel AAN

Druk op knop 1  en houdt ingedrukt om instrument en pomp aan te schakelen.

Dit zorgt voor opwarming..

Alle LCD segmenten worden getoond

gevolgd door het instrument type en de software versie,

en daarna de batterij status, zoals getoond:

De LEL alarmwaarden alterneren tussen LEL en HI.

Dan toont het instrument, met maand en jaar, wanneer de volgende kalibratie moet plaatsvinden.

KNOP 1

KNOP 2

KNOP 3

KNOP 4

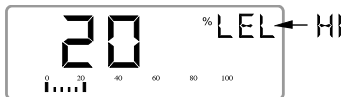
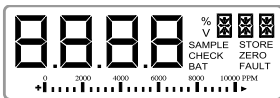

(Kalibratie nodig)
Juli 2003

(Afwisselend knipperlicht)

De display wordt gevolgd door het lezen van de huidige gasdetectie.

Pompsnelheid AAN / HI / UIT

Een enkele druk op knop 1  wanneer de pomp draait, selecteert hoge pompsnelheid (verhogen stroombereik). Een volgende druk schakelt de pomp uit en stopt het meten. Nog een volgende druk schakelt de pomp weer aan met normale snelheid.

Wijzig bereik

Elke enkele druk op knop 2  wijzigt het bereik. De display loopt door de beschikbare bereiken in deze volgorde: PPM – LEL – PPM etc.

Nota: Het instrument gaat van bereik LEL naar Volume Gas.

Nul PPM Bereik

Een dubbele druk op knop 3 , indien PPM bereik geselecteerd is, zet het bereik op nul. Dit moet in open lucht gebeuren.

Alarmen verwijderen

Een dubbele druk op knop 4 , herkent het alarm gedurende 60 seconden indien “non-hatching”.

Schakel hoorbaar “Geiger” Alarm AAN/UIT

In PPM gas detectie bereik zal een enkele druk op knop 4  de hoorbare Geiger aanduiding activeren.

Indien aan, zal de display wisselen tussen PPM en Aud:

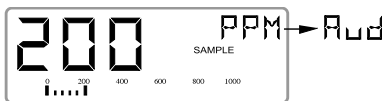

Een volgende druk op knop 4  vermindert de aanduiding.

Schakel UIT

Een dubbele druk op knop 1  schakelt het instrument uit. Gedurende 5 seconden van de uitschakeltijd wordt OFF op de display getoond. Om de uitschakeling te onderbreken, druk op één van de vier knoppen van het instrument.

Index

Symbols

1 19

A

ACCESSORIES 41

Activate Audible Geiger
Indication 16

ADDITIONAL INFORMA-
TION 45

Alarm Functions 6

Alarms 5

Alarms, Clearing 16

Alkaline (LR20) Batteries
7, 28

APPLICATIONS, PROBE
B-1

AREAS OF USE ii

Audible Geiger Indication
16

B

BAT 19

BAT FAULT 19

Batteries 7

Battery Pack 25, 27, 28

Before Use Checks 9

Bellows Probe 23, B-4

C

CALIBRATION 39

Calibration Due Date
Features 14

Calibration Validity 40

Carpet Probe 22, B-3

Carpet Probe Assembly
8, 32

Changing Range 15

Charger, Flatbed 26

Charger, Smart 26

Charger, Standard 25

CHECK ZERO 18

Clearing Alarms 16

Connection of Probe 13

Construction 6, A-2

COPYRIGHT i

D

Dansk (Danish) C-1

Date Features 14

Deutsch (German) C-1

Display 9, A-2

DISPOSAL ADVICE i

Dust Filter 37

E

EEEE 19
English C-1

F

FAULT, BAT 19
Fault Flags 18
FAULT, ZERO 18
features 2
Features, Instrument 11
Filter, Dust 37
Filter Replacement 30
Filter, Water 36
Filters 8
Flags, Fault 18
Flatbed Charger 26
Functions, Alarm 6

G

Geiger, Audible 16
Geiger Indication 16
GENERAL INFORMATION
3

H

HANDLING ii
Humidity A-2

I

IMS 39
In-line Dust Filter 37
In-line Water Filter 36
INFORMATION, ADDI-
TIONAL 45
INFORMATION, GEN-
ERAL 3
INSTRUCTIONS, OPER-
ATING 11
Instrument Features 11
Instrument Pump High
Speed / Off Selection
15
INTRODUCTION 1

L

LCD 9, A-2
LEL 4
LIABILITY i
Liquid Crystal Display 9
L'italiano (Italian) C-1

M

MAINTENANCE, OPERA-
TOR 25
Messages, Operator 18
MODIFICATION NOTICES
i

N

Nederlands (Dutch) C-1

O

OFF 18

Off 15

On, Switching 13

OPERATING INSTRUCTIONS 11

OPERATING PARAMETERS A-1

Operating Temperature A-2

Operation 13

Operation Summary 16

Operation, Switch 17

OPERATOR MAINTENANCE 25

Operator Messages 18

P

PARAMETERS, OPERATING A-1

Power Source A-3

ppm (Semiconductor Sensor Range) 6

ppm Range (Semiconductor Sensor) 3

Probe and Handle Assembly 21

PROBE APPLICATIONS B-1

Probe, Bellows B-4

Probe, Carpet 8, 22, 32, B-3

Probe Handle Assembly 8, 30

Probe, Stainless Steel (Flue) B-7

Probe, Standard 8, 21, 30

Probe, Survey 8, 35

PROBES 21

Pump High Speed / Off Selection 15

Pump, Instrument 15

R

Range, Changing 15

Range, ppm 3 ranges 2

Ranges of Operation 3

Rechargeable Battery Pack 7, 25

Recharging the Battery Pack 28

Replacing Alkaline (LR20) Batteries 28

Replacing the Battery Pack 27

REVISION RECORD iii

S

SAMPLE 18
SAMPLE FAULT
 18, 30, 35
Sampling System A-2
Size A-2
Small Plastic (Open End)
 Probe B-2
Small Plastic (Solid End)
 Probe B-1
Smart Charger 26
SOFTWARE i
Source, Power A-3
Standard Charger 25
Standard Probe and
 Handle Assembly 21
Standard Probe Handle
 Assembly 8, 30
STORAGE ii
Summary, Operation 16
Survey Probe Handle
 Assembly 8, 35
Svensk (Swedish) C-1
Swan Neck Probe 23
Swan Neck Probe B-6
Switch Operation Summary
 17
Switch Panel 12
Switching Instrument Off
 15
Switching On 13

T

Temperature, Operating
 A-2
Training 45
TRANSIT ii

V

Volume Gas 5

W

Water Filter 36
Weight A-2
World Wide Web 45

Z

ZERO, CHECK 18
ZERO FAULT 18
Zeroing the ppm Range
 Indication 16



Thank you for reading this data sheet.

For pricing or for further information, please contact us at our UK Office, using the details below.



UK Office

Keison Products,

P.O. Box 2124, Chelmsford, Essex, CM1 3UP, England.

Tel: +44 (0)330 088 0560

Fax: +44 (0)1245 808399

Email: sales@keison.co.uk

Please note - Product designs and specifications are subject to change without notice. The user is responsible for determining the suitability of this product.