

**Multi-Spectrum Digital
Electro-Optical Fire Detection**

**FS2000TM
FIRE EARLY
WARNING SYSTEM**

**Installation Guide
and
Operating Manual**

Read and understand this manual before installing or operating equipment.

No part of this document may be copied or reproduced without the express written permission of Fire Sentry Corporation (FSC).

This manual is subject to change without notice.

ACCTTL, ALERT-1, ALARM-2, ALERT-1: ALARM 2, ALERT-1: ALARM-2, ATAG, Clean Room Sentry, COP-i, Complete Optical Path Integrity, CM1, CM1-A, DartLogic, FireLogic, Fire Signature Analysis, FireBusI, FireBusII, FirePic, FirePicII, FirePicIII, FirePix, FirePicture, FSC, Fire Sentry Corporation, Fire Sentry Corp., FSX, All FSX Nomenclature Variations (such as: FS2, FS2X, FS3, FS3X, FS4, FS4X, FS5, FS5X, FS6, FS6X, FS7, FS7X, FS8, FS8X, FS9, FS9X, FS10X, FS10X, FS11, FS11X, FS12, FS12X, FS14, FS14X, FS15, FS15X, FS16, FS16X, FS17, FS17X, FS18, FS18X, FS19, FS19X, FS20, FS20X, FS24, FS24X, FS24XN, FS26, FS26X, FS26XN), FS7-2173-2RP, FS System 7, FS System 10, FS7-2173, FS7-2173-RP, FS2000, FS System 2000, High Speed Flame & Surveillance Detector, Multi-Spectrum QuadBand Triple IR, Multi-Spectrum TriBand, Multi-Spectrum Tri-Band, Near Band Infrared, Near Band IR, NearBand IR, QuadBand IR, Room Sentry, RS, RS2, SM2, SM3, SS, SS2, SS2X, SS2-A, SS3, SS3-A, SS3X, SS4, SS4-A, SS4X, SnapShot, SLR-BIT, SuperBus, SuperSentry, System 2000, Tri-Mode Plot, QuadBand Triple IR Plus, TriBand, Tri-Band, "FS & FSC triangle logo's", WBIR, Wide Band Infrared, WideBand IR, Wide Band IR

are Trademarks of Fire Sentry Corporation (FSC), Yorba Linda, California.

©Copyright 1998 - 2009 by Fire Sentry Corporation (FSC)



FS2000 Fire Early Warning System Installation and Operations Guide

TABLE OF CONTENTS

	PAGE
SECTION 1 FAMILIARIZATION	1
1.1 Introduction	1
1.2 Overview	1
1.2.1 Detector.....	1
1.2.2 Test Source.....	1
1.2.3 Controller.....	1
1.2.4 FireBus	2
1.3 Multilevel FS2000.....	2
1.4 System Configuration.....	3
SECTION 2 INSTALLATION.....	5
2.1 Installation Procedure	5
2.1.1 Installation Precautions	5
2.1.2 Conduit Installation	5
2.1.3 FireBus Wiring Recommendations	6
2.1.4 Power Supply Considerations.....	7
2.2 FireBus Installation	7
2.3 Housing Installation.....	10
2.4 Wiring Detectors and Sources	12
2.4.1 Wiring Devices With Junction Boxes and Flying Leads.....	12
2.4.2 Custom Wiring.....	12
SECTION 3 CONTROLLER OPERATION	14
3.1 Wiring the FS2000 System	15
3.2 Initialization	17
3.2.1 Initialization Requirements.....	17
3.2.2 Initializing the System	17
3.2.3 Initializing Detector Zoning and Voting	18
3.3 FS2000 System Operating Modes	19
3.3.1 NOT-Initialized	19
3.3.2 Normal.....	19
3.3.3 Fire	20
3.3.4 Fault	20
3.3.5 Test	20
3.3.6 Manual Detector Test.....	21
3.4 Multilevel FS2000.....	21
3.4.1 Multilevel Operation	21
3.4.2 Multilevel Zoning and Multilevel Voting.....	21
3.4.3 Multilevel Fire and Fault Reporting	21
3.5 RS-232 Communications	21
3.6 Advanced System Monitoring	22
SECTION 4 MAINTENANCE AND TROUBLESHOOTING.....	23
4.1 Personnel.....	23
4.2 Controller Faults.....	23
4.2.1 Controller Messages	23
4.3 Cleaning Windowed Housings and Detectors	25
4.4 Detector and Test Source Faults	25
4.5 Detector and Test Source Replacement.....	25
4.6 Detector and Test Source Repair	26
SECTION 5 PINOUT DATA.....	27
INDEX	29

SECTION 1: FAMILIARIZATION

1.1 Introduction

The FS2000 Fire Early Warning System features SuperSentry Models SS2, SS3, and SS4 series Multi-Spectrum Optical Fire/Flame Detectors, Models TS2 and TS3 series COP-i Test Sources, and CM1 series Controllers. The FS2000 System uses Complete Optical Path Integrity (COP-i) testing to perform testing of *both* the Detector's window and the Detector's optical path.

1.2 Overview

1.2.1 Detector

The **Model SS2, SS3, and SS4 series Multi-Spectrum Optical Fire/Flame Detectors** are micro computerized devices that see the ultraviolet, visible, and infrared spectral bands. The Detector's logic "brain" alarms to fires quickly while virtually eliminating nuisance false alarms. The Model SS Detectors have a 120° field-of-view.

There are two red LED's (lights) on the Model SS2 and Model SS4 Detectors' faceplate. If both of the LED's blink every 10 seconds, then the Detector is operating normally. If only one LED is turned on, then there is a Fault condition, such as Detector malfunction or a very high temperature. Both LED's remaining turned on indicates that the Detector has alarmed to a fire.

The indoor Model SS3 has one red LED. If the LED stays turned on, the Detector has alarmed to a fire. Its LED blinks every 10 seconds to indicate normal operation.

Once a fire is alarmed, the Detector will turn on its Fire relay and report the fire over the FireBus to the FS2000 Controller.

1.2.2 Test Source

The Model TS2 and TS3 COP-i Test Sources are used to perform COP-i testing. The Controller directs COP-i testing when there are COP-i Test Sources installed.

The FS2000 Controller will start a COP-i test by turning on a COP-i Test Source. When it is turned on, the COP-i Test Source emits a simulated fire signal which the Detectors report to the Controller. This tests the Detectors, the Controller, the COP-i Test Source, and the path between the Detectors and the Test Sources. This type of end-to-end test serves to insure that each Detector has a view of the fire threat area and that its optical viewing window is not dirty. If a Detector or Test Source is blocked or obstructed or non-functional, the Controller will display a Fault condition.

1.2.3 Controller

The FS2000 Controller governs the overall operation of the System 2000. The major features of the FS2000 Controller are listed below.

- A two-line LCD display shows system status.
- Fire and Fault history files are stored in permanent memory.
- There is an optional RS-232 communications channel.
- There are five Zones with Detector voting in each Zone and cross-zoning.
- The enclosure is a welded-seam steel dust-tight NEMA 5 housing.
- A heavy-duty 16 Amp SPDT relay is used as a Fault Relay.
- Each Zone has a heavy-duty 16 Amp SPDT Fire relay.

The FS2000 System has Zoning and voting capability. Detectors can be grouped to form Zones with multiple Zones possible for each Detector (Cross-Zoning). A minimum number of alarming Detectors in a Zone may be specified for the FS2000 Controller to declare a Fire Alarm. Zone 1 is a master Zone that will alarm if the voting requirements for Zone 1 are met or if any other Zone goes into alarm. The Zone 1 relay must therefore be used as the System Fire Relay. A Controller will support up to five (5) Zones with voting in each Zone. Zoning and voting information is entered into a Controller via built-in push button switches during System Initialization.

The Controller will indicate a Fire alarm by:

- lighting its Red LED,
- turning on its LCD display's back lighting,
- sounding its Siren at a 110 dB,

- activating the Relay assigned to that Zone,
- activating the Relay for Zone 1,
- displaying the alarm date and time and
- displaying either the name of a Detector in the alarming Zone or
- the alarming Zone number and the serial number of an alarming Detector in that Zone.

Pushing the "ALARM SILENCE" button on the Controller enclosure during a Fire alarm will cause the siren to chirp instead of sounding continuously. Pushing the "RESET" button on the Controller printed circuit (PC) board inside the enclosure will clear the alarm and stop all the indicators listed above until another fire is reported.

Pressing the "ALARM SILENCE" and "Reset" buttons are electronically recorded in the Controller's History file.

The FS2000 System also has Detector voting. For example, if there are three Detectors in Zone 4, the Controller may be programmed to alarm when one Detector alarms to a fire, when two Detectors alarm to a fire, or when all three Detectors alarm to a fire. If the number of properly operating Detectors reduces to less than the vote required (because of removal or malfunction), the Zone will alarm based on all operating units. There must be at least one operating Detector in order for a Zone to alarm.

If a Fault or is detected within the FS2000 System, the Controller will;

- de-energize its Fault relay,
- display a Fault message on its LCD display,
- turn on its Yellow Fault LED, and
- its Siren will chirp.

These conditions will continue until the Fault condition is corrected.

1.2.4 FireBus

All FS2000 System devices are interconnected by the FireBus loop. A maximum of 30 devices may be attached to the FireBus loop of any FS2000 Controller and the maximum loop length is 4000 feet. The four conductor FireBus loop supplies the 24 volt DC power and RS-485 digital communications to all devices (Detectors and Test Sources) as shown in Figure 1. The FS2000 Controller supervises its FireBus loop. If the FireBus loop is cut or not operating properly, then a Fault message will be displayed on the Controller.

1.3 Multilevel FS2000

If more than a single FS2000 Controller is required, then the FS2000 System may be operated in a **MULTILEVEL** configuration. The multilevel configuration allows multiple Controllers and a large number of Detectors and Test Sources to be operated as one system, with Fire and Fault messages being accessible on a single Controller (see Figure 2).

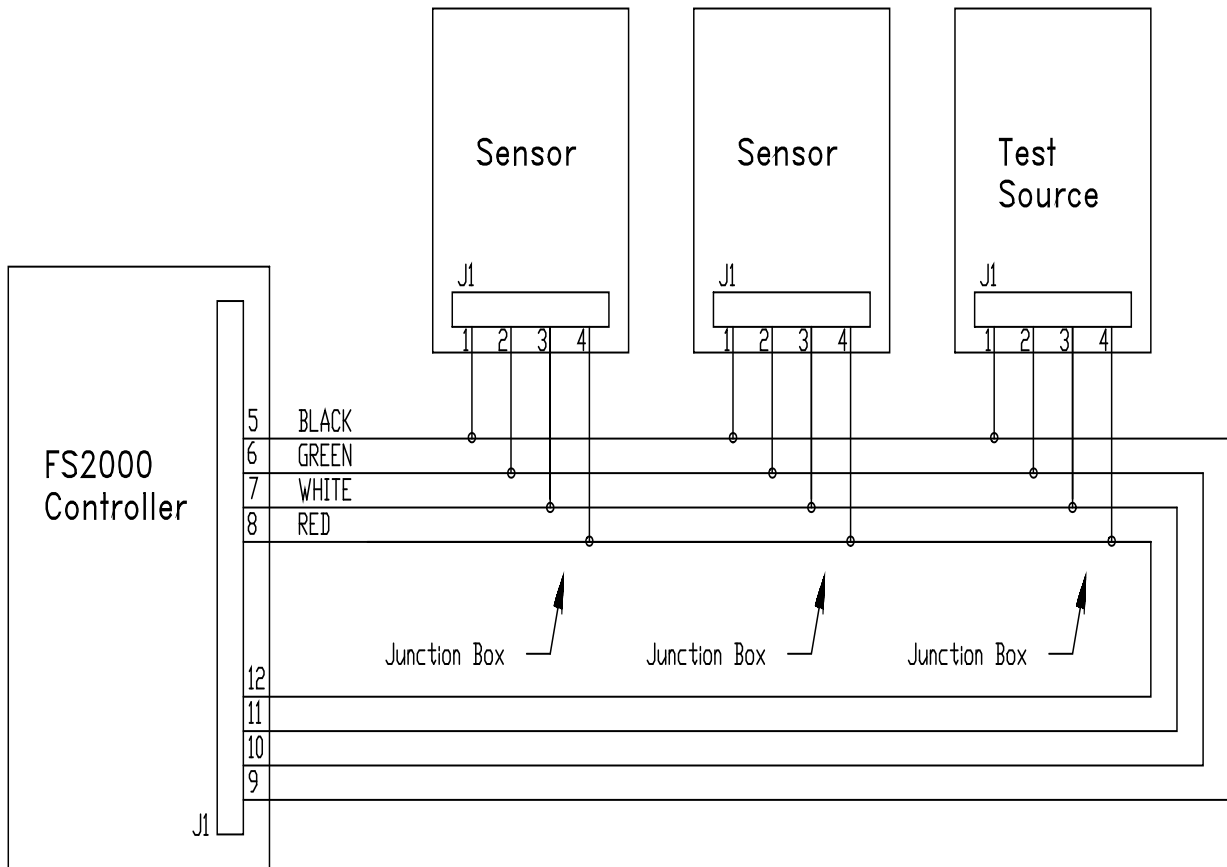

Figure 1
FireBus Wiring

1.4 System Configuration

System monitoring is possible with the UC2000 User Communications program, and an IBM PC-AT or compatible computer. See Section 3.6, Advanced System Monitoring and Programming, or contact any Fire Sentry Corporation representative for more information about UC2000.

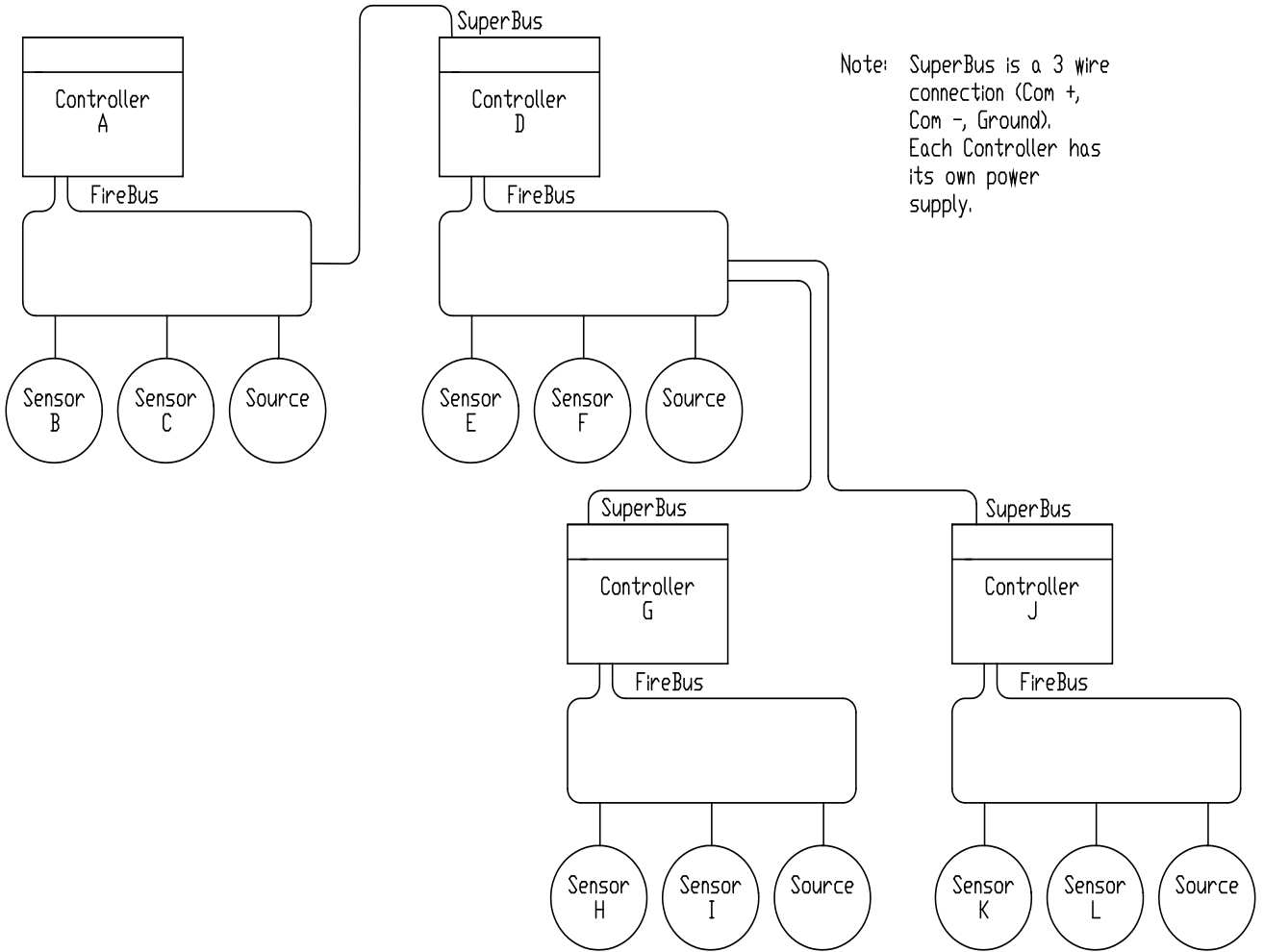

Figure 2
Multilevel Wiring

SECTION 2: INSTALLATION

2.1 Installation Procedure

This section describes the installation of the FS2000 Controller, the Detectors, the COP-i Test Sources, and the FireBus wiring. Section 3 describes power-up and Initialization of the FS2000 System.

The recommended procedure for installing the entire FS2000 System is as follows:

1. Plan the placement of all devices.
2. Install the conduit, junction boxes, and device enclosures.
3. Install the Controller (see Section 2.2.)
4. Run the wire for FireBus and relay activated equipment. Connect FireBus to the junction boxes. Check FireBus carefully for opens and shorts using a DVM.
5. Wire the Controller to FireBus.
6. Apply power to the Controller and Initialize it according to the instructions in Section 3.2.2. The Controller should display the Fault message "NO DEVICES ON LINE."
7. Remove power from the Controller. Wire one **Detector** to FireBus (connect the flying leads to the junction box). Apply power to the Controller and Initialize again.
8. If there are no problems, repeat step 7, adding one more Detector or Test Source each time, until all devices are connected.
9. When the system is Initialized and all FireBus devices are functional, then begin connecting the relay activated equipment to the system and testing according to the manufacturers' directions.

Each step of this procedure is explained in the following sections. Use of this procedure will minimize installation time and reduce effort needed to diagnose any problems that may occur.

2.1.1 Installation Precautions

The following precautions should be observed during installation of the FS2000 System.

1. Double-check to make sure that the external electrical power is turned **OFF** before connecting to the Controller. The FS2000 does not have an ON/OFF switch and the system will turn on when EITHER external power OR battery power is installed. **Do NOT supply power to the FS2000 System until instructed to do so in Section 3.**
2. **Do not handle a printed circuit board without being adequately grounded.** Printed circuit boards are susceptible to damage from electrostatic discharge. Grounding may be accomplished by wearing an anti-static wrist strap connected to an earth ground.

2.1.2 Conduit Installation

Detectors should be located to cover the specific "fire threat" areas. The COP-i Test Sources should be located near the fire threat area, within a 60 degree field-of-view of the Detector(s) and normally within 50 feet of the appropriate Detector(s). The Detectors view of the Test Source should be as near to on axis as is reasonable.

When planning the conduit, observe the following recommendations.

1. If only one of the two ½ inch NPT conduit openings on the Detector / Test Source enclosure is used, seal the unused opening with a threaded plug.
2. In areas where moisture may accumulate, install an approved conduit trap or drain.
3. To maintain the NEMA 5 Dust-Tight rating of the Controller panel, an approved dust-tight conduit hub must be used.
4. For Class I, Div. 1 & 2 Explosion-Proof installations, a seal shall be installed within 6 inches of the enclosure.

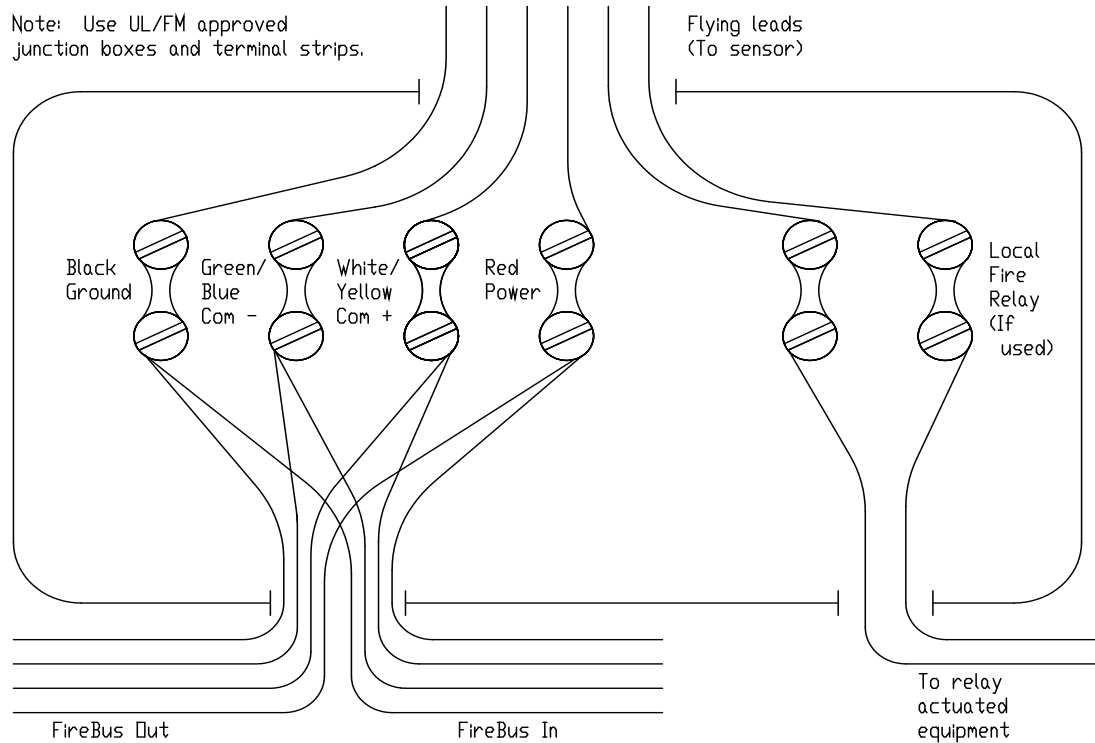

Figure 3
Junction Box Wiring

2.1.3 FireBus Wiring Recommendations

The cable used for FireBus should be 4-conductor, shielded, UL-rated fire Signaling Cable. The FireBus wire size depends on the length of the cabling to be used and on the number of Detectors to be used as follows:

- If **fewer than 8 Detectors** are on the FireBus **OR** if the FireBus loop length is **less than 1000 feet**, then **22 gauge** wire may be used.
- If **fewer than 15 Detectors** are on the FireBus **OR** if the FireBus loop length is **less than 2000 feet**, then **20 gauge** wire may be used .
- If **more than 15 Detectors** are on the FireBus **OR** if the FireBus loop length is **more than 2000 feet**, then **18 gauge** wire, or heavier must be used.

The characteristics of the interconnecting cable used for FireBus communications shall conform to the specifications for RS-485. The cable shall have a characteristic impedance in the general range of 120 ohms to frequencies greater than 100 kHz, and a DC series loop resistance not exceeding 120 ohms. The wire resistance shall not exceed 20 ohms per 1000 feet per conductor. Mutual pair capacitance between the 2 communications wires shall not exceed 20 picofarads per foot. Stray capacitance between any other pair of wires shall not exceed 40 picofarads per foot.

Detectors and Sources for FS2000 System installations are supplied with flying leads (short lengths of wire pre-connected to the device). Fire Sentry Corporation recommends using junction boxes to prevent problems with intermittent connections.

To use the flying leads, first wire the FireBus as a loop, with a junction box near each device location. Next, wire each device (Detector or Test Source) to its junction box. Use screw-down terminal strips inside the junction box to make the connections. Use UL/FM-approved junction boxes and terminal strips (see Figure 3).

Avoid wire splices. However, if they are necessary, solder all splices. Never use wire nuts to make connections. It is recommended that any connections to the FireBus be made using junction boxes. The use of good wiring practices will greatly improve the ease of installation, improve system reliability, and allow easier servicing of the system.

2.1.4 Power Supply Considerations

The standard FS2000 System Controller, with a maximum of 30 devices connected to its FireBus, uses a nominal 115 Volts single phase AC at a nominal input current of 0.5 amps. In this configuration, the Controller's AC power supply consumes less than 60 watts and it can have an input current surge of up to 43 amps during the first half cycle of operation. For safety, each Controller should have its own circuit breaker.

For Backup Power operation, an Uninterruptable power supply (UPS) is required to supply primary power to the FS2000 System Controller. A UPS rated for 24 hours of operation is needed in order to comply with NFPA 72 standards.

2.2 FireBus Installation

1. **TO INSTALL THE CONTROLLER PANEL BOX** - use a secure wall or surface. To prevent damaging the Controller PC board and its components during panel box installation, it is recommended that panel box mounting and conduit hole punching/drilling be done with the PC Board removed from the panel box. **Take care to be grounded when handling the Controller PC board since it is subject to static damage.**
2. **PROCEDURE TO RE-INSTALL CONTROLLER PC BOARD IN ITS PANEL BOX**
 - a. Mount the five ½ inch standoffs to the posts in the Controller panel box.
 - b. Mount the power supply base plate to the Controller panel box standoffs.
 - c. Fasten with the five 1 ½ inch standoffs.
 - d. Mount the Controller board to the standoffs.
 - e. Fasten with the slot head screws.
 - f. Wire the power supply to the Controller. Attach the black wire to pin 1 and the red wire to pin 2.
 - g. Wire the "ALARM SILENCE" button to the Controller. Pass the blue twisted wire pair under the aluminum base plate from top to bottom, and connect the wires to Controller Pins 19 and 20. (It does not matter which blue wire connects to Pin 19 or 20.)
 - h. Wire the siren to the Controller. Pass the siren's red/black twisted wire pair under the aluminum base plate from top to bottom. Connect the "black wire" to Controller Pin 21 and the "red wire" to Pin 22.
3. **CONNECT THE DETECTOR AND TEST SOURCE DEVICES** - FireBus should be connected by wires in metal conduit with a four-wire parallel loop configuration (see Figure 1). FireBus starts at Pins 5, 6, 7 and 8 of the 40-pin connector (dual 20 pin side-by-side removable connectors) on the Controller. It then proceeds out to the devices that are to be connected to FireBus and then returns back to Pins 9, 10, 11 and 12 of the Controller. A maximum of 30 devices may be connected to each Controller.

Wire FireBus to the Controller as follows:

Pins 5 & 9	Pins 6 & 10	Pins 7 & 11	Pins 8 & 12
Black	Green or Blue	White or Yellow	Red
GROUND (-)	COMM (-)	COMM (+)	POWER (+)

Connect the FireBus shield to Pin 5. Shield wires should be tied to ground at only one point on the loop. Therefore, on the return end (Pin 9), cut the shield close to the cable insulation to prevent accidental shorting to an exposed surface. Do not wire the shield to the Controller at pin 9.

4. **CONNECT SUPERBUS** - If this is a multilevel installation and this Controller is to be slave to another Controller, then this Controller's SuperBus port will be connected to the FireBus loop of another Controller (referred to as the master). Wire the master Controller's FireBus to this Controller's SuperBus as follows:

Pin 13	Pin 14	Pin 15
Black	Green or Blue	White or Yellow
Ground (-)	Comm (-)	Comm (+)

Do not wire the master Controller's FireBus power (the red wire) to the SuperBus port. Twist the FireBus cable shields together, but do not connect them to the Slave Controller.

5. **CONNECT THE RS-232 COMM PORT** - When used, the RS-232 port is wired as follows:

Pin 16	Pin 17	Pin 18
Black	Green or Blue	White or Yellow
Ground	Tx	Rx

6. **CONNECT RELAYS** - Wire the six SPDT relays (Controller Pins 23 to 40) to UL/FM approved equipment as required. The Fault relay (Pins 38, 39 and 40) is **normally energized**. This is to insure, that in addition to other faults, a loss of input power will cause the Fault relay to go to its **ON** (Fault) state. The Fire and Fault relays are shown in the figures in their **NORMAL** operating conditions; that is, the condition of no Fire and no Fault.

7. **CONNECT THE EXTERNAL AC SUPPLY** - If external AC power is used, connect electrical power to the FS2000 Controller's AC/DC power supply located below its PC Board. Connect the AC leads as follows (see Figure 4).

Black	Green	White
L	G	N
Line	Ground	Neutral

If this is not a slave Controller, then verify that the jumper between DC (-) and the large ground screw on the Controller's power supply board is in place as shown in Figure 4. Do not make battery connections or turn on external AC power at this time.

8. **CONNECT THE DC SUPPLY** - Connect electrical power to the FS2000 Controller (see Figure 4). Connect the (+) DC of the Controller's power supply (if an external 24 volt supply is being used, then connect the **positive** input line) to PIN 2 of the Controller. Connect the (-) DC of the power supply (if an external 24 volt supply is being used, then connect the **negative** input line) to PIN 1 of the Controller. **Do NOT make battery connections OR turn on external power at this time.**

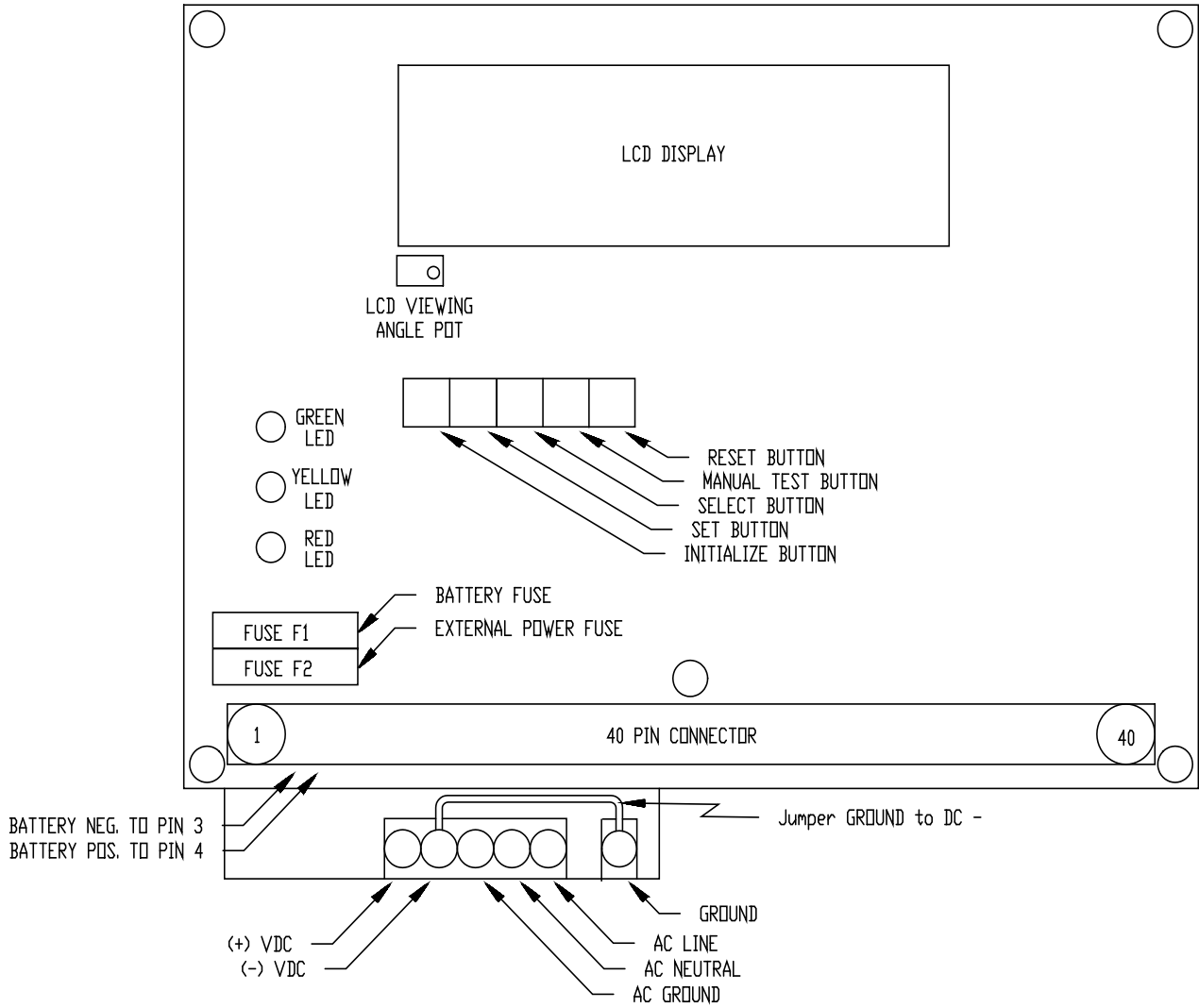
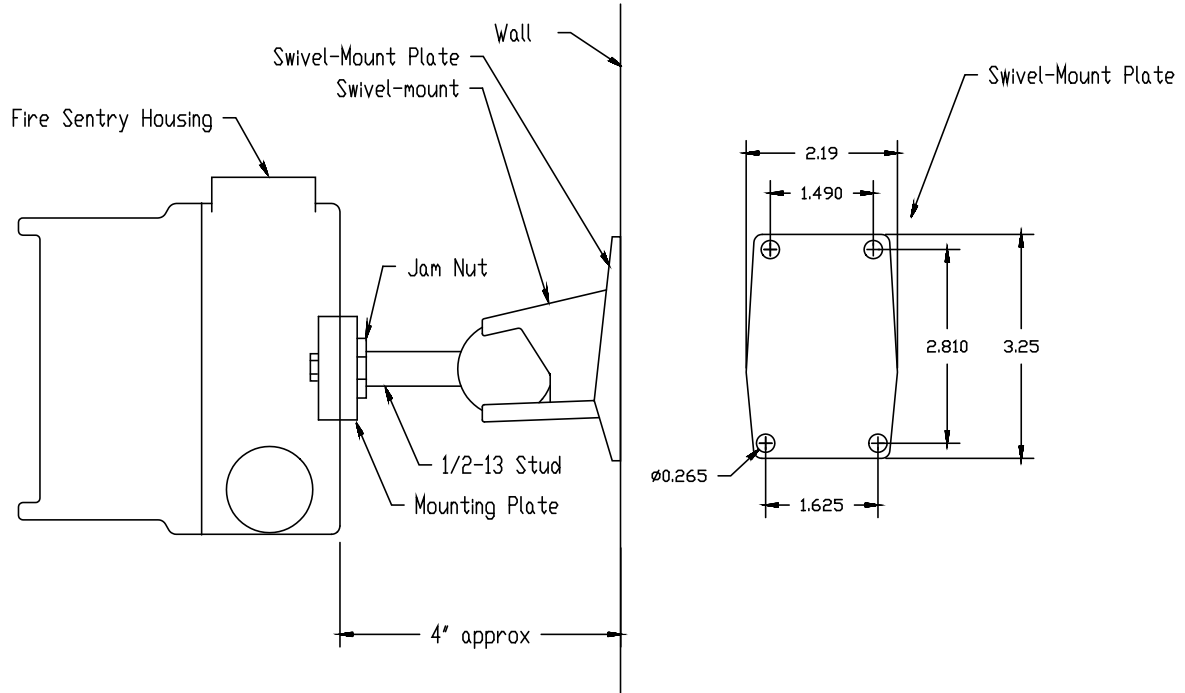

Figure 4
FS2000 Controller Layout

Figure 5

Detector / Test Source Swivel Mount



2.3 Housing Installation

1. INSTALL THE DETECTOR AND TEST SOURCE SWIVEL MOUNTS.

- a. Choose fasteners for the swivel-mount that will secure it solidly to the type of material at the enclosure location.
- b. Mount the swivel-mount to the wall. Do not install upside down.
- c. Install the mounting bracket onto the Detector/COP-i enclosure using ¼-20 screws and nuts provided. Be sure the bracket is mounted with the correct orientation. The outside contours of the mounting ears on the Detector/COP-i enclosure and the ends of the bracket will match. The large diameter of the threaded insert must be facing the enclosure.
- d. Screw the enclosure/bracket assembly on to the ball stud. Turn the Detector until the stud bottoms against the enclosure. **Do not tighten.** While holding the enclosure, tighten the jam nut against the bracket.
- e. While holding the enclosure, loosen the socket head screw on the swivel-mount. Position the enclosure so that the conduit openings are on the bottom and horizontal. Point the enclosure in the desired direction and tighten the socket head screw.

2. **INSTALL CONDUIT AND PREPARE TO WIRE FIREBUS.** If it is not already installed, then the FireBus conduit should be installed at this time.

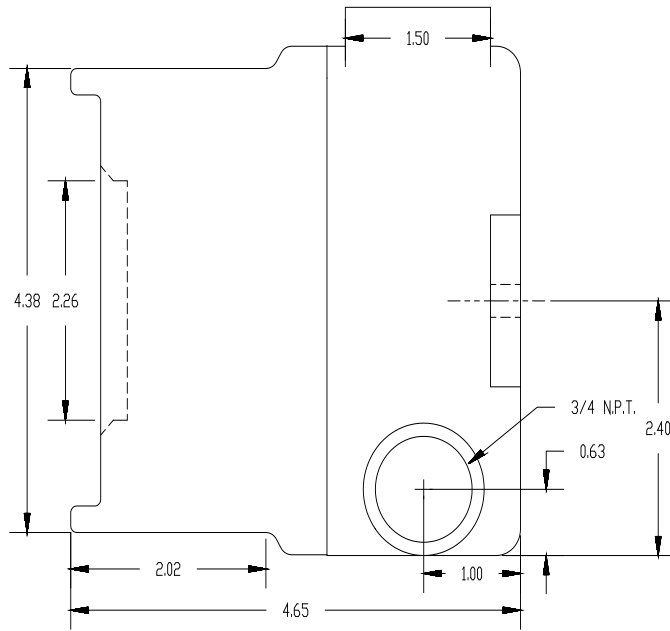
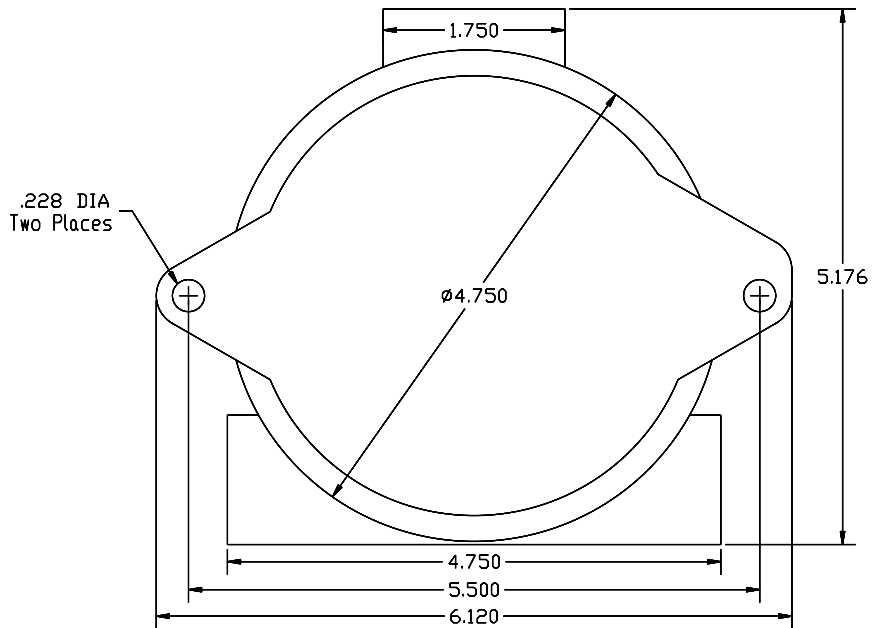

Figure 6
Detector / Test Source Enclosure - Side View

Figure 7
Detector / Test Source Enclosure Rear View



2.4 Wiring Detectors and Sources

Flying leads are provided on the Detectors and Test Sources to facilitate wiring of FS2000 System installations. In special cases, custom wiring configurations may require removing the modules from the enclosures to connect wires directly to the modules.

2.4.1 Wiring Devices With Junction Boxes and Flying Leads

If junction boxes were installed as recommended in Section 2.1.3, then wire the flying leads to the junction box. Wire each conductor of the four conductor FireBus to the same color on the terminal strip:

Black	Green or Blue	White or Yellow	Red
Ground (-)	Comm (-)	Comm(+)	Power (+)

Flying leads for the Fire relay are optional and should be specified when ordering if use of the local Detector Fire relay is required. When wiring the two conductor relay leads to the relay connections on the terminal strip this pair of leads is either black and white, or black and red.

2.4.2 Custom Wiring

To custom wire the devices, the modules may have to be removed from the enclosures. When the FireBus:Wiring; and the Fire relay connections are made, then replace the modules in the enclosures (see Figure 6).

Exercise caution while performing this procedure. Do not touch the sensors on the front of the modules. If they are accidentally touched, clean them as instructed in Section 4.3, Cleaning Windowed Housings and Detectors.

CAUTION: Observe static protection safeguards while handling modules. Properly wear a wrist strap connected to earth ground.

1. REMOVE THE DEVICE MODULE FROM THE HOUSING.

- a. First double check that electrical power is off by seeing that the Detector's LED's do NOT blink for at least 10 seconds. With Controller electrical power off, loosen the Allen-head screw at the base of the metal enclosure top windowed cover.
- b. Unscrew the top windowed cover and set it aside with its "O" ring. Keep both clean.
- c. Loosen/remove the three slot headed screws located on the top circuit board. (Some models use captive screws which should not be removed from the circuit board).
- d. Gently lift out the module, sliding it along the three metal standoffs.

2. WIRING THE DETECTOR OR TEST SOURCE DEVICE MODULE.

- a. Insert the FireBus cables into the metal enclosure base through one of the conduit openings.
- b. Then connect the FireBus loop to the four-pin WECO connector, terminal J1. Install the FireBus wires into the WECO connector and firmly tighten down the four slotted screws with a small screwdriver. Do NOT over tighten or the screws may strip or break. Refer to Figure 1, FireBus Wiring, and Figure 8, Detector Wiring.

Pin 1	Pin 2	Pin 3	Pin 4
Black	Green or Blue	White or Yellow	Red
Ground (-)	Comm (-)	Comm (+)	Power (+)

Twist the FireBus shields together and then tape the leads to insure that they do not accidentally touch an exposed surface. Do not connect the shields to the Detector or Test Source.

3. WIRE THE LOCAL DETECTOR FIRE RELAY (IF REQUIRED.)

- a. Insert the relay cables into the metal enclosure base through one of the conduit openings.
- b. Next, connect the wires to the four pin WECCO terminal J3. Install the wires into J3 pins 1 and 2 and firmly tighten down the slotted screws with a small screwdriver (refer to Figure 8, Detector Wiring, for more details on relay connections).

4. RECORD THE DEVICE SERIAL NUMBER AND LOCATION INFORMATION necessary for completing the Device Location Sheet. The device serial number is a six digit number unique to each Detector or Test Source in the FireBus loop. The device serial number is physically located on a white label on the circuit board of the device module. The Device Location Sheet (located inside the front door of the FS2000 Controller) should be filled out prior to system Initialization. A copy of the Device Location Table is provided in Figure 9 for convenience.

5. REPLACE THE MODULE INTO THE HOUSING.

- a. Gently install the module back over the three metal standoffs and secure it with the three chrome-plated screws.
- b. If necessary, clean the detectors and windowed cover according to the instructions in Section 4.3.
- c. Screw down the metal enclosure top windowed cover until secure and tighten the Allen-head "tamper-proof" screw.

**Figure 8
Detector Wiring**

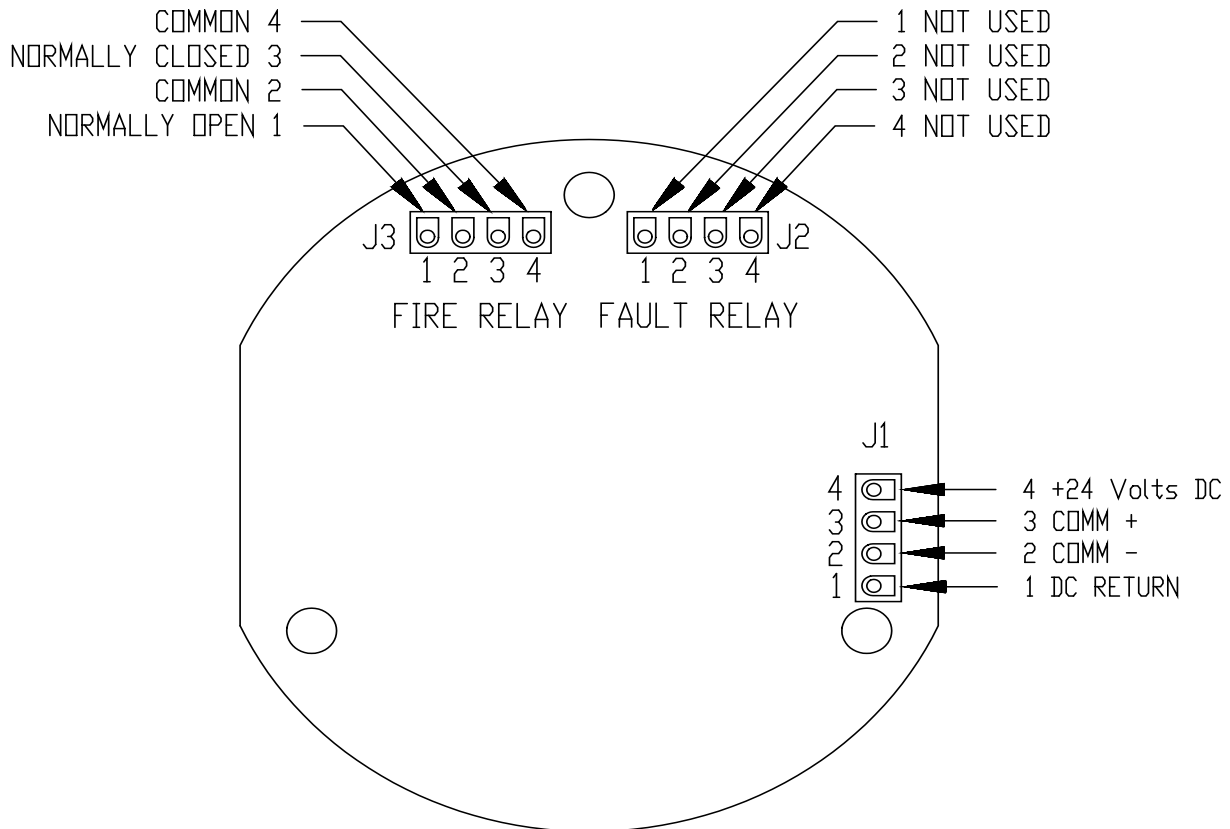

BOTTOM VIEW OF SENSOR MODULE

**Figure 9
Device Location Table**

FS2000 Fire Early Warning System			
Device #	Location	Device #	Location
1.	_____	16.	_____
2.	_____	17.	_____
3.	_____	18.	_____
4.	_____	19.	_____
5.	_____	20.	_____
6.	_____	21.	_____
7.	_____	22.	_____
8.	_____	23.	_____
9.	_____	24.	_____
10.	_____	25.	_____
11.	_____	26.	_____
12.	_____	27.	_____
13.	_____	28.	_____
14.	_____	29.	_____
15.	_____	30.	_____

SECTION 3: CONTROLLER OPERATION

3.1 Wiring the FS2000 System

The FS2000 System Controller does **NOT** have an ON/OFF switch - **the System turns ON when either the external Power is turned on or the backup battery is installed to the Controller PC Board.**

1. **APPLY EXTERNAL POWER.** At this time, turn the external power ON. If a backup battery is not being used, then proceed to step 4.
2. **CONNECT THE HARNESS TO THE BATTERIES** as shown in Figure 10. To connect the supplied batteries, first place both batteries in the Controller box so that the terminals are located on the right-hand side as shown in Figure 11. Then connect the red leads of the harness to the red "+" terminals of the batteries, and the black leads of the harness to the black "-" terminals of the batteries.

**Figure 10
Controller Battery Connections**

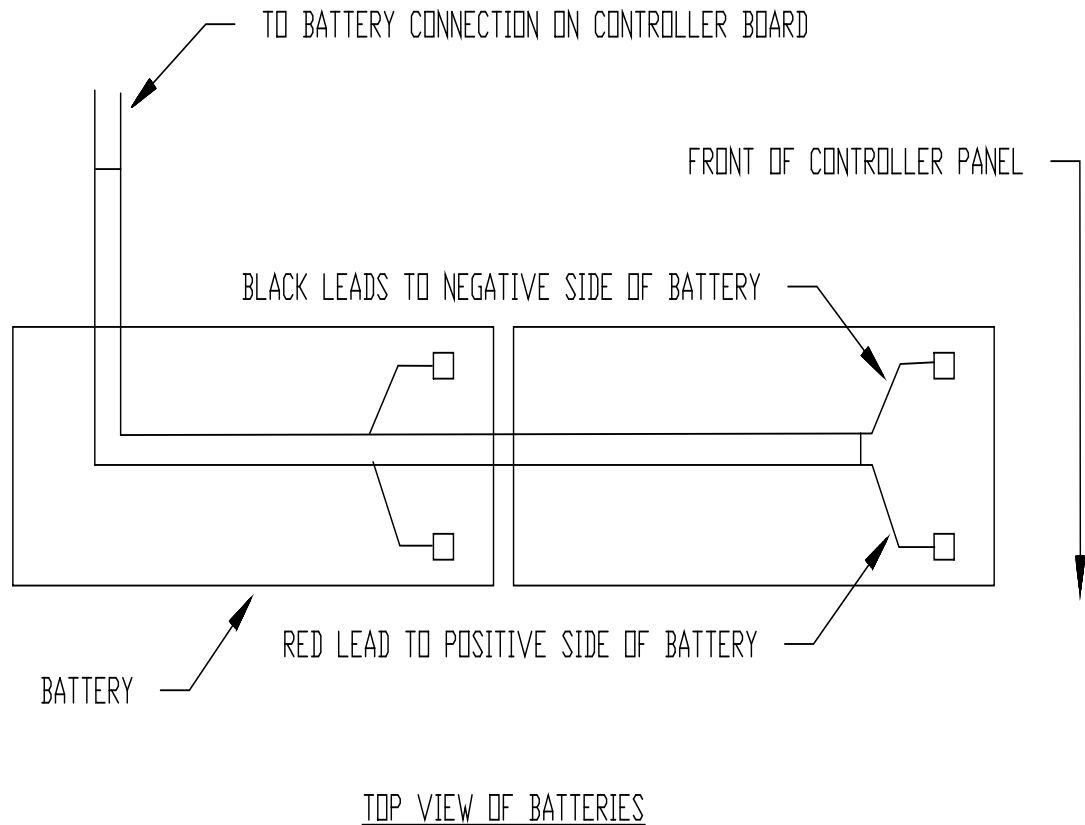

NOTES: 1. All dimensions are in inches.

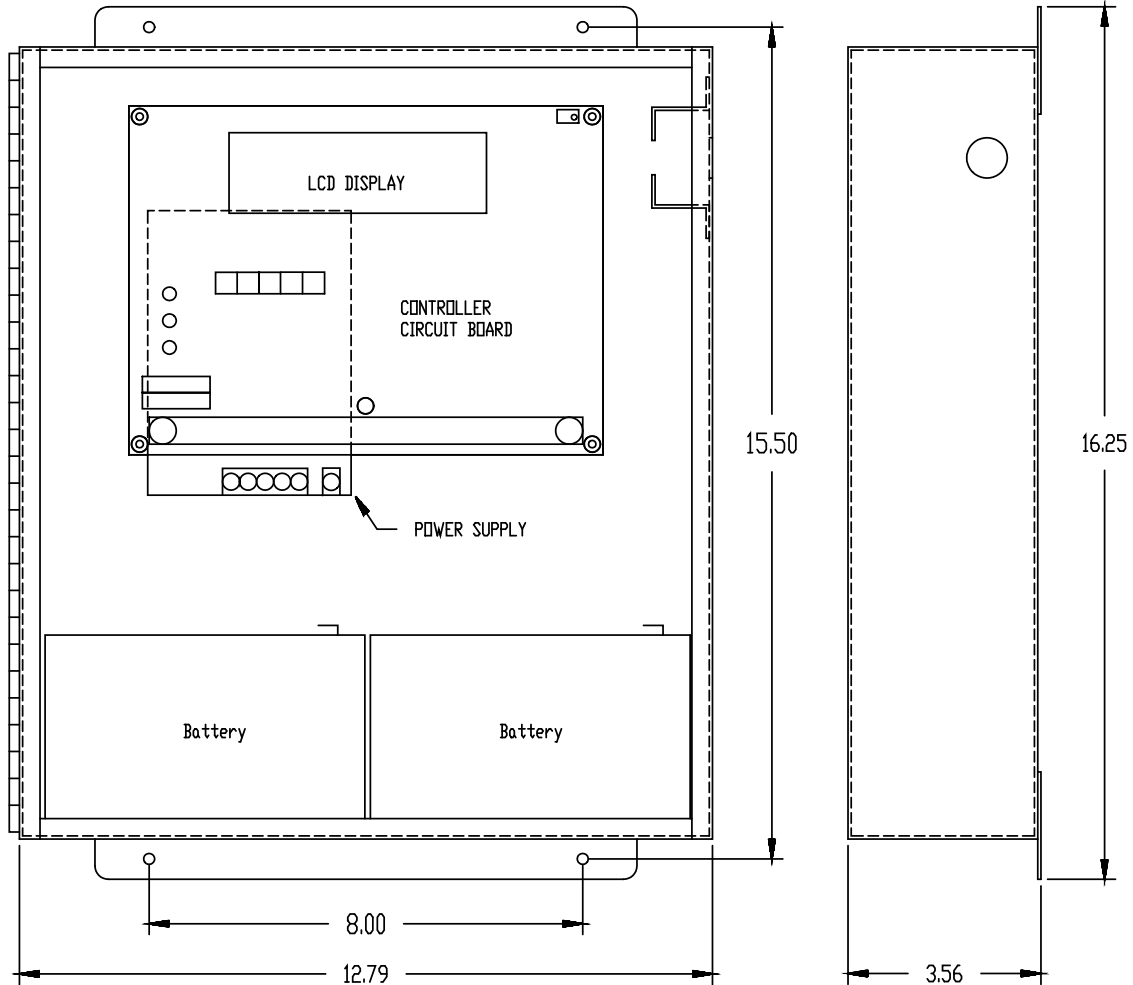

**Figure 11
Controller Battery Locations**

3. **CONNECT THE POWER SUPPLY 24 volt BATTERY** set to the Controller terminal pins (see Figure 4). Connect the red "+" wire to Pin 4 and black "-" wire to Pin 3.
4. The Controller's yellow LED will turn **on** while the red and green LED's remain **off**. This indicates that the Controller is NOT-Initialized and its LCD Display will read:

INITIALIZATION REQUIRED
mm/dd/yy hh:mm:ss

If the Controller had been previously Initialized, the message on the display may be different than shown. Whatever message is displayed, the Controller still requires Initialization.

3.2 Initialization

3.2.1 Initialization Requirements

System Initialization is how the Controller establishes communications with all devices on its FireBus, creates the COP-i configuration and allows user configuration of the System for a specific application. During Initialization the system will not report a fire.

Initialization may be done at any time, but is required to be done when:

- the first time the system is powered,
- any time a device is removed from FireBus,
- any time a device is added to FireBus,
- any time a device on FireBus is replaced with another device,
- if the system time or date changes, or
- if Detector zoning or voting configuration changes.

After Initialization, the Controller will display the number of devices (Detectors and Sources) it has detected on FireBus (a slave Controller will be reported as a Detector). Check carefully to verify these device counts. (Note: Each Detector or Test Source counts as one device. For example, 20 Detectors and 10 Test Sources equals the maximum 30 devices.) If a device stops communicating with the Controller and the system is Initialized again, there may be no other warning that a device is missing.

The FS2000 system will not Initialize if the FireBus loop wiring is not intact. It is recommended that the FireBus loop be tested for opens and shorts with a DVM before attempting to Initialize.

During Initialization, the Test Sources generate a simulated fire signal and these readings are used to establish a "clean" window level for the Detectors. For this reason, all Test Source and Detector windowed covers should be cleaned before Initialization occurs. If they are not clean before Initialization, the system may not properly notify the user when the windows are dirty.

Multilevel systems must be Initialized in the proper order. Initialize from the bottom up; in other words Initialize all slave Controllers first, then their master Controllers, and so on, with the top level Controller Initialized last. For example, in Figure 2, Initialize Controllers C and D first, then Controller B, and finally Controller A. See Section 3.4 for a complete discussion of multilevel systems, including definitions of master and slave devices.

3.2.2 Initializing the System

Refer to Figure 4 throughout this procedure for the location of the Controller's push buttons.

1. **Press and hold down the "INITIALIZE" button** - black, labeled "**S1 INITIAL**".
2. **While holding down the "INITIALIZE" button, press and then release the "RESET" button** - red, labeled "**S5 RESET**".
3. **Continue holding down the "INITIALIZE" button until the "SYSTEM INITIALIZING" message appears on the LCD display.**
4. **Release the "INITIALIZE" button.** The yellow LED will remain on while the green and red LED's remain off.
5. **Wait for the green LED to light.** This should occur within 10 minutes, depending on the number of Detectors and Sources connected to the FireBus. The yellow LED will still be illuminated. The LCD will display how many Detectors and Test Sources are connected to the FireBus. **Then verify that the displayed number of Detectors and Sources is correct.**

Note: If any message other than the number of Detectors and Sources with date and time appears, check the Fault table in Section 4.2.1 for the appropriate action.

6. **Set the "DATE AND TIME"** - At the completion of Step 5, the date and time may be set. To change the date and time:
 Press and hold the "CLOCK SELECT" button - black, labeled "S3 CLOCK SELECT" - until the digits you wish to change are flashing. The "month" will flash initially.
 Then Press and hold the "CLOCK SET" button - white, labeled "S2 CLOCK SET" - until the correct value is displayed. Note that the FS2000 System uses a 24-hour clock.
7. **If all of the Detectors are to be assigned to Zone 1 and there is no voting to be implemented, then press the "RESET" button on the Controller.** All Detectors will begin operating and the system will be in the *NORMAL* operating mode. The yellow LED will extinguish leaving just the green. Skip Section 3.2.3, Initializing Zoning or Voting, and go directly to Section 3.3, FS2000 Operating Modes.

Note: For ten seconds after pushing the "RESET" button, the Controller and its Detectors are Initializing and will NOT declare a Fire.

8. **This was the first of three windows for initializing the system.** Pressing the "INITIAL" button (S1) cycles through each window. Each window may be repeated until everything is correct.

3.2.3 Initializing Detector Zoning and Voting

Initialization of zoning and voting is performed while the Controller is in the Initialization mode (still displaying the number of Detectors and Sources message). If the Controller is not in this mode, then follow the instructions in Section 3.2.2, Initializing the System.

1. **Press the "INITIAL" button (S1).** The following message will be displayed:

```

XXXXXXXX,  ZONE #    U,V,W,X,Y
mm/dd/yy   hh:mm:ss    COP-i
  
```

where:

- **XXXXXXXX** is the device serial number.
- **ZONE #** is Zone 1, 2, 3, 4, or 5.
- **U, V, W, X, Y** is the list of zones the Detector has been assigned to.
- **mm/dd/yy** is the month, day, and year.
- **hh:mm:ss** is the time (hours, minutes, seconds) in 24-hour clock format.
- **COP-i** indicates the Detector has detected a source, and *NONE* indicates no source has been detected.

Note: If COP-i Test Sources are installed and Detector has not detected a COP-i Test Source, then check for physical path blockage. If the optical path between the Detector and the appropriate Test Source appears clear, then adjust the location of the Test Source to provide either a shorter path or better Detector view angle. Additional COP-i Test Sources may be used to provide better coverage.

2. Press the "CLOCK SET" button (S2) to select the Detector device serial number XXXXXX that you wish to assign. This may be cycled through until all Detectors are correct.
3. Press the "CLOCK SELECT" button (S3) until a desired Zone number is displayed.
4. Press the "MANUAL TEST" button (S4) to add or delete the selected zone from the list. The list will update showing all zones the Detector has been assigned to. At least one zone must always be assigned for a Detector. The process will not allow the last zone on the list to be deleted. If changing one zone to another, add the new zone first and delete the old zone second. Pressing "CLOCK SELECT" allows for cycling through all zones repeatedly.
5. Press the "INITIAL" button again. The Controller's LCD will display:

ZONE #, XX DET'S/ALARM
mm/dd/yy hh:mm:ss COP-i

where:

- **XX** is the number of Detectors alarming to fire required for this Controller Zone to go into alarm (this is called *Voting*).
6. Press the "CLOCK SET" button to select a Zone number. This may be repeated until all Zones have been properly configured.
 7. Press the "CLOCK SELECT" button to select the number of Detectors in that Zone required for alarm. The process only allows up to the number of units assigned to the zone, and then will cycle back to 1.
 8. Press the "INITIAL" button again.

Note: If the zoning information was not set correctly, then the zoning procedure may be repeated as many times as necessary.

9. BE SURE THE LCD DISPLAY SHOWS THE DETECTOR AND SOURCE COUNT MESSAGE:

nn DET'S, nn SOURCES
mm/dd/yy hh:mm:ss

If it does not, **press** the "INITIAL" button again until the message appears. Then **press** the "RESET" button. This starts the System in the NORMAL mode. (Pressing "RESET" without returning to the Detector and Test Source count message may cause all zoning and voting information to be lost or distorted. If this happens, repeat Section 3.2.3.)

3.3 FS2000 System Operating Modes

3.3.1 NOT-Initialized

The system is shipped in the NOT-Initialized state and must be Initialized before it will operate properly. In the NOT-Initialized mode, the Controller will have its yellow LED on and the green and red LED's off.

3.3.2 Normal

In the Normal operating mode, the FS2000 System is ready to alarm to fires and report Faults, should any occur. In the NORMAL mode, the Controller will have the green LED on and the yellow and red LED's off, and the following message on the LCD Display:



FS2000 ON	VER X.XX
mm/dd/yy hh:mm:ss	

3.3.3 Fire

During a Fire Alarm condition, the Controller will:

- turn on its red LED,
- sound its siren at 110 dB,
- record the event in its Fire History file,
- energize the Fire Relays for the alarmed Zone and Zone 1,
- backlight its LCD display, and
- show on its LCD display a message stating which Detector device is in alarm:

ALARM	ZONE #,	DET	XXXXXX
mm/dd/yy hh:mm:ss			

If the Detector alarming has been named, the name will replace the alarm message on the LCD display's top line. (Note: "Naming" a Detector requires using the UC2000 program with a PC-AT compatible computer - see Section 3.6.)

If the "ALARM SILENCE" button on the Controller's front panel is pressed, the siren will change from continuous to chirp mode (one loud beep every 10 seconds) and the yellow Fault LED will turn on. The "ALARM SILENCE" Button only works when the Controller has already declared a Fire. The LCD display message will state that the siren has been hushed (changed to chirp mode). If a second Zone alarms during this hush condition, the system will return to full alarm mode. To clear the Controller press and release the red "RESET" button located on the Controller PC Board.

If the local Fire relay on the Detector is used, it will energize as soon as the fire is detected. The relay will remain energized until the "RESET" button is pushed on the Controller. The Detector may be configured for the relay to remain energized for a specified time period and then de-energize.

3.3.4 Fault

During a Fault condition, the Controller will:

- turn ON its yellow Fault LED,
- chirp its siren,
- show a Fault message on its LCD display, and
- de-energized its Fault relay (#6).

The Fault message will indicate the type of system Fault condition. The Fault message display is self-curing; if the condition causing the Fault is remedied, then the Controller will stop reporting a Fault condition.

Faults generally occur for three reasons:

- the FS2000 System's internal self-checking uncovered a hardware failure in one of the devices,
- an FS2000 System problem has been encountered, such as a cut FireBus cable, a contaminated lens, a high or low voltage or
- the environment warrants a warning, for example, there is very high ambient temperature.

A complete description of all types of Faults may be found in Section 4, Troubleshooting, along with a recommended course of action for each.

3.3.5 Test

When COP-i Test Sources are installed, the FS2000 System Controller performs periodic COP-i tests to check the operation of the Detectors. During a COP-i test, the LCD display indicates that a COP-i test is in progress. While this test is occurring the system is still functional and able to alarm on a fire.

The FS2000 System executes a COP-i test every 30 minutes (set at the factory) and will display a Fault message if a Detector detects an inadequate COP-i Test Source signal. Weak Test Source signals indicate dirty windows or partially blocked optical paths.

3.3.6 Manual Detector Test

To start a manual Detector test, first press the Manual Test Button on the Controller board - white, labeled "S4 MANUAL". The Controller's LCD will display "MANUAL TEST MODE".

At this time, the FS2000 System may be checked using a Handheld Test Source. Go to each Detector location and point the Test Source unit at the Detector. Turn ON Handheld Test Source for about 3 seconds. The Detector will detect the simulated electro-optical fire signal and the Controller will display "MANUAL TEST DET #XXXXXX", where XXXXXX will be the Detector device serial number.

Repeat this action for each Detector connected to the Controller.

In the event that a real fire occurs while the system is in manual test mode, the system will override the test mode and respond with full siren and relay activation to the fire after approximately 10 seconds.

To return to normal mode from manual test mode, press the red "RESET" button.

3.4 Multilevel FS2000

The FS2000 system may be used in a multilevel configuration if more than 30 devices or more than 5 Zones are needed. Using a multilevel configuration allows multiple Controllers and a large number of Detectors and Test Sources to be operated as one system, with Fire and Fault messages being displayed on a single Controller. Figure 2 shows a multilevel FS2000 system.

3.4.1 Multilevel Operation

The FS2000 Controller is the master of all devices on its FireBus, while all other devices on FireBus are slaves. The slave devices are normally Detectors and Test Sources, but for multilevel operation, additional Controllers also are slave devices. The master Controller's FireBus is connected to a slave Controller's SuperBus port. The configuration is iterative, as illustrated in Figure 2. Controller A is master to several Detectors, Test Sources, and Controller D on its FireBus. Controller D is slave to Controller A on its SuperBus port, and master to several Detectors, Sources, and Controllers G and J on its FireBus. Controllers G and J are slaves to Controller D on their SuperBus ports, and each one is a master of Detectors and Sources.

Note that no power is supplied to a SuperBus port. Each Controller, master or slave, has its own power supply for itself and its FireBus Detectors and Sources.

3.4.2 Multilevel Zoning and Multilevel Voting

A slave Controller looks like a single device to its master Controller. For example, assume that in Figure 2, Controller A has three devices on its FireBus: Detector B, Detector C, and Controller D. All are assigned to Zone 1, and Zone 1 voting requires two devices to report fire before the Controller declares Fire. Controller A will alarm if any two of the devices alarm: if Detectors B and C alarm, if Detector B and Controller D alarm, or if Detector C and Controller D alarm. Controller A will not alarm if only two devices on Controller D's FireBus alarm, such as Detectors E and F, since this condition appears to Controller A as only one device, Controller D, alarming.

3.4.3 Multilevel Fire and Fault Reporting

On a FireBus each slave device will report a Fire condition to its master Controller. For example, assume in Figure 2 that both Controllers A and D are not using voting, then if Detector F detects fire, both Controllers A and D will declare Fire. Moreover, both Controllers will report the device serial number of Detector F on their LCD's as the device alarming to the fire.

Fault reporting works somewhat differently. For example if Detector F Faults (see Figure 2), then both Controllers A and D will also Fault. But while Controller D would report that Detector F had Faulted, Controller A would report that Controller D, not Detector F, had Faulted.

3.5 RS-232 Communications

The RS-232 port is provided to optionally connect the FS2000 Controller Panel to a monitoring device. The port has the following configuration:



Baud: 9600
Parity: None
Data Bits: 8
Stop Bits: 1

The RS-232 port will respond to the following requests:

STATUS The Controller will respond with its status: "FIRE", "FAULT", or "NORMAL".
TIME The Controller will respond with the time in the format "hh:mm:ss".
DATE The Controller will respond with the date in the format "mm/dd/yy".
NAME The Controller will respond with the first line from its LCD display.

During NORMAL operation, the response will be "FS2000 VER X.XX", which is the "Name" of the system. The response will always be 25 characters.

3.6 Advanced System Monitoring

Advanced user communication is possible with the UC2000 program (User Communications for the FS2000). Use of UC2000 requires an PC using an 80286-based compatible computer or higher with DOS 3.1 or higher with VGA or higher graphics capability. The FS2000 Controller's RS-232 port in Section 3.5 is used with the UC2000 program. Contact any FSC representative for more information and pricing of UC2000.

SECTION 4: MAINTENANCE AND TROUBLESHOOTING

4.1 Personnel

The following will aid in troubleshooting the FS2000 Fire Early Warning System. Tests must be performed by qualified authorized personnel observing standard safety practices.

WARNING: Hazardous voltages are present during testing procedures. Serious injury or death may result if personnel fail to observe safety precautions.

CAUTION: Model SS2 and SS4 Detector and Model TS2 Test Source modules and their components are susceptible to permanent damage due to electrostatic discharge (ESD). Do NOT handle a module without adequate grounding precautions. If a Model SS2, SS4, or TS2 Module must be shipped back to the factory for repair, it MUST be packed in static protected material. If static protected material is not available, carefully wrap the Module in aluminum foil. Do not damage the delicate sensor elements

4.2 Controller Faults

4.2.1 Controller Messages

The two types of Fault messages reported by the Controller are (Initialization and Operational Faults) shown in the following table.

The Fault messages are displayed on the top line of the Controller's two-line by 24-character LCD display. The recommended actions for each respective Fault condition are next to each Fault message.

CONTROLLER FAULT TABLE

<u>LCD FAULT MESSAGE</u>	<u>ACTION</u>
INITIALIZATION REQUIRED	The system is not presently INITIALIZED or was incompletely Initialized and requires Initialization before use.
INITIALIZATION FAULT	The INITIALIZATION procedure timed-out before completing. Check the wiring and INITIALIZE again. If problem remains, try INITIALIZING repeatedly with only one device added for each Initialization.
NO DEVICES ON-LINE	Check the wiring and INITIALIZE again. If problem remains, try INITIALIZING repeatedly with only one device added for each INITIALIZATION.
NO DET'S ON LINE	Check the wiring and INITIALIZE again. If problem remains, try INITIALIZING repeatedly with only one device added each Initialization.
DET INIT FAULT	Detector cannot be INITIALIZED. Return Detector to the factory for service.
OVER 30 DEVICES ON LINE	Too many devices are wired to the FireBus. The maximum number of devices is 30.
FIRE RELAY FAULT	If this condition persists, then return the Controller to the factory for service.
DET #XXXXXX FAULT	Read Section 4.4, Detector and Test Source Faults, to see if the reason for the Fault can be detected and corrected. If this condition persists, then return the Detector to the factory for service.
SOURCE #XXXXXX FAULT	Read Section 4.4, Detector and Test Source Faults, to see if the reason for the Fault can be detected and corrected. If this condition persists, then return the designated Test Source to the factory for service.
DEVICE #XXXXXX FAULT	If this condition persists, then return the device to the factory for service.
LOOP CUT	The FireBus loop is not intact. Check FireBus wiring and repair. Use a DVM.
PRIMARY POWER FAULT	Restore external Electrical Power.
BATTERY FAULT	Check for loose battery terminal, and check battery voltage under load. If there is no loose wiring, then replace the battery set.
MAINT REQUIRED #XXXXXX	This Fault is happens when the Detector does not detect enough of the radiant electro-optical energy generated by the Test Source during a test. Clean the Detector/Test Source outer windows. After cleaning, press the red "RESET" button on the Controller Board.
COP-i PATH FAULT #XXXXXX	This Fault is generated when the Test Source is not detected by the corresponding Detector during a COP-i test. The serial number displayed is that of the Test Source being used for the COP-i test. In this case, the Test Source or Detector may no longer functional or there is a object blocking the path between the Test Source and the Detector. Remove physical path blockage, and clean the Detector and Test Source windows. After cleaning or removing any blockage, press the red "RESET" button located on the Controller PC Board.
ALARM ZONE #, DET #XXXXXX (HUSH)	ALARM SILENCE (HUSH) button on the Controller has been pressed while a Fire Alarm was being declared. To end the Fault condition and to clear the Fire Declaration, press "RESET" on the Controller PC Board.

4.3 Cleaning Windowed Housings and Detectors

Clean the windows on the Fire Detectors and Test Sources before Initialization, after handling, and whenever a Controller Fault occurs for which that is the recommended action. Clean the sensors whenever Detectors have been disassembled for wiring or replacement. To prevent static damage to the electronics, remember to be grounded whenever working with open devices.

Use a blast of an air hose or an oil-free cloth to clean the devices. Oil degrades the performance of UV Detectors. Occasionally, the use of a solvent such as alcohol may be required. No disassembly of the Detector is required. **DO NOT USE SILICONE-BASED OR COMMERCIAL WINDOW CLEANING PRODUCTS AS THEY WILL DEGRADE THE DETECTOR PERFORMANCE.**

4.4 Detector and Test Source Faults

A Detector or Test Source may Fault and the FS2000 Controller will display one of the following messages:

DET #XXXXXX FAULT
mm/dd/yy hh:mm:ss

SOURCE #XXXXXX FAULT
mm/dd/yy hh:mm:ss

This indicates either a hardware malfunction in the device or a problem in the device's environment. The following conditions cause a device to Fault:

- **High temperature in the Detector area.** The Detector will Fault if the temperature reaches approximately 85°C or above.
- **Input voltage out of range.** The voltage should be approximately 24 Volts. This Fault indicates a problem with either the supply or the FireBus wiring.
- **An internal device problem.** If this condition persists, then return the device to the factory for service. There are no user-serviceable parts within these devices.

4.5 Detector and Test Source Replacement

CAUTION: Model SS2 and SS4 Detector and TS2 Test Source modules and their components are susceptible to permanent damage due to electrostatic discharge (ESD). Do NOT handle a SS or TS module without adequate grounding precautions.

1. With Controller electrical power off, loosen the Allen-head screw at the base of the metal enclosure top windowed cover. (Double-check and see that the Detector's LED's do NOT blink for at least 10 seconds.)
2. Unscrew the top windowed cover and set aside with its "O" ring. Keep both clean.
3. Loosen, then remove the three slot headed screws located on the top circuit board. (Some models use captive screws which should not be removed from the circuit board).
4. Gently lift out the module, sliding it along the three metal standoffs.
5. Disconnect all of the wires from the female jack located on the bottom of the module.
6. Install another module. Make sure the module is correctly aligned, gently re-install back over the three metal standoffs and re-install the three chrome-plated screws. **Be careful not to touch the sensors or Test Source element.** If they are accidentally touched, clean as instructed in Section 4.3, Cleaning Windowed Housings and Detectors.



-
7. Screw down the metal enclosure top windowed cover until it is secure and tighten the Allen-head "tamper-proof" screw.

4.6 Detector and Test Source Repair

If a device, module, or Controller PC Board must shipped back to the factory for repair or service, it **MUST** be packed in static protected material. If this material is not available, carefully wrap the Module or Controller PC Board in aluminum foil. An RMA (Return Material Authorization) is required for all returns to the factory. Contact Customer Service for an RMA number before shipping a unit back to the factory.

**THERE ARE NO USER SERVICEABLE PARTS IN A
DETECTOR OR TEST SOURCE MODULE.**

SECTION 5: PINOUT DATA

TABLE 1: Detector and Test Source Connector Pin-outs

J1: DETECTOR or TEST SOURCE (4 pin WECO connected to FireBus Loop)

PIN

- 1 FireBus Ground (-)**
- 2 FireBus COMM -**
- 3 FireBus COMM +**
- 4 FireBus DC (+) Power**

(Note: COMM as it is used in this document is an abbreviation for Communications)

J3: LOCAL FIRE RELAY ONLY

PIN

- 1 Fire Relay Common**
- 2 Fire Relay Normally Open**
- 3 Fire Relay Common**
- 4 Fire Relay Normally Closed**

TABLE 2: Controller PC Board - Connector Pinout

PINS	DESCRIPTION
1	DC (-) Ground
2	DC (+) Power
3	Battery (-) Negative Lead
4	Battery (+) Positive Lead
5	FireBus DC (-) Ground Out
6	FireBus Comm - Out
7	FireBus Comm + Out
8	FireBus DC (+) Power Out
9	FireBus DC (-) Ground Return
10	FireBus Comm - Return
11	FireBus Comm + Return
12	FireBus DC (+) Power Return
13	SuperBus DC (-) Ground
14	SuperBus Comm -
15	SuperBus Comm +
16	RS-232 DC (-) Ground
17	RS-232 TX
18	RS-232 RX
19	Alarm (Siren) Silence Button (blue lead)
20	Alarm (Siren) Silence Button (blue lead)
21	Siren DC (-) Ground (black lead)
22	Siren DC (+) Power (red lead)
23	Relay #1 Common (Zone 1: Master Zone Relay)
24	Relay #1 Normally Closed
25	Relay #1 Normally Open
26	Relay #2 Common (Zone 2 Relay)
27	Relay #2 Normally Closed
28	Relay #2 Normally Open
29	Relay #3 Common (Zone 3 Relay)
30	Relay #3 Normally Closed
31	Relay #3 Normally Open
32	Relay #4 Common (Zone 4 Relay)
33	Relay #4 Normally Closed
34	Relay #4 Normally Open
35	Relay #5 Common (Zone 5 Relay)
36	Relay #5 Normally Closed
37	Relay #5 Normally Open
38	Relay #6 Common (Fault Relay)
39	Relay #6 Normally Open
40	Relay #6 Normally Closed

NOTE: All Controller relays are shown as they are during NORMAL Mode, that is, no Fire or Fault. The Fault relay (#6) is energized in the NORMAL mode.

INDEX

- A**
- Advanced System Monitoring, 3
 - ALARM SILENCE, 2
 - ALARM SILENCE See Siren:, 20
 - ALARM ZONE, SEN (HUSH), 24**
- B**
- Battery, 5, 7
 - Fault, 21, 24
 - BATTERY
 - Installation, 15
- C**
- Cabling, 6
 - Chirp See Siren:, 2
 - Cleaning Products, 25**
 - Communication Bus See FireBus:, 1
 - Conduit, 5
 - Controller, 1
 - Fault, 23
 - Features, 1
 - Fire Alarm, 2
 - Installation, 7
 - Pinout, 28**
 - COP-i, 1
 - Fault, 24
 - Initialization, 17
 - Operation, 21
 - Path blockage, 1, 19, 24
 - COP-i PATH FAULT, 24**
 - COP-i Test Source See Test Source:, 1**
 - Cross-Zoning, 1
- D**
- DEVICE FAULT, 24**
 - Devices
 - Adding to FireBus, 17
 - Definition of, 17
 - Internal problem, 25
 - Location number, 13
 - Masters, 21
 - Missing on FireBus, 17
 - Removing from FireBus, 17
 - Replacing on FireBus, 17
 - Serial number, 13
 - Slaves, 21
 - Digital Voltmeter (DVM), 5, 17
- E**
- ESD, 5
- F**
- False Alarms, 1
 - Fault, 2, 20
 - Battery, 21
 - Controller, 23
 - COP-i, 24
 - FireBus, 21, 24, 25
 - High temperature, 21
 - Initialization, 24
 - Multilevel, 22
 - Power, 24, 25
 - Relay, 2, 21, 24
 - Self-curing, 21
 - Sensor, 24, 25
 - Temperature, 25
 - Test Source, 24
 - Field-of-View, 1, 5
 - Fire, 2, 20
 - Multilevel, 22
 - Relay, 20
 - FIRE RELAY FAULT, 24**
 - Fire Sensor See Sensor:, 1
 - FireBus, 1, 2, 27
 - COP-i, 1
 - Cut cable, 21
 - Fault, 21, 24, 25
 - Initialization, 17
 - Installation, 7
 - Multilevel, 21
 - Wiring, 7
 - FireBus
 - Wiring, 6
 - FIREBUS
 - Wiring, 12
 - FireLogic, 1
 - Flame Sensor See Sensor:, 1**
 - Flying Leads, 6, 12
 - FS2000 Controller See Controller:, 1**
- G**
- Grounding, 5
- H**
- Hush See Siren:, 2
- I**
- Infrared (IR) Band, 1
 - Initialization, 17
 - Fault, 24
 - Voting, 18
 - Zoning, 18
 - INITIALIZATION FAULT, 24**
 - INITIALIZATION REQUIRED, 24**
 - Installation, 5
 - Cabling, 6
 - Conduit, 5
 - Controller, 7
 - FireBus, 7
 - Housing, 10
 - Precautions, 5
 - Sensor, 12
 - Static Damage, 5
 - SuperBus, 8
 - Test Source, 12
- J**
- Junction Box, 5, 6, 12
- L**
- Layout Planning, 5
 - LED
 - Fault, 21
 - One LED on, 1
 - Two LED's on, 1
 - LOOP CUT, 24**
- M**
- MAINT REQUIRED, 24**
 - Maintenance, 23
 - Maximum Devices, 2
 - Maximum Loop Length, 2
 - Model CM1 See Controller:, 1
 - Model SS2 See Sensor:, 1
 - Model TS2 See Test Source:, 1
 - Multilevel, 2, 21
 - Fault, 22
 - Fire, 22
 - Initialization order, 17
 - Installation, 8
 - Reporting, 22
 - Voting, 22
 - Multilevel
 - Operation, 21
 - Zoning, 22
 - Multi-Spectrum See Sensor:, 1**
- N**
- NEMA 5, 5
 - NO DEVICES ON LINE, 24**
 - NO SENSORS ON LINE, 24**
- O**
- Optical Fire Sensor See Sensor:, 1**
 - OVER 30 DEVICES ON LINE, 24**
- P**
- PC Board
 - Printed Circuit Board, 2
 - Personnel - Qualified, 23
 - Power, 7
 - AC, 5, 15, 24
 - Failure, 7
 - Failure, 2
 - Fault, 24, 25
 - Starting up, 15
 - Wiring, 7, 8
 - PRIMARY POWER FAULT, 24**
- R**
- Relay, 1
 - Fault, 2, 21, 24
 - Fire, 20
 - Local Fire, 12, 20, 27
 - LOCAL FIRE, 12
 - Wiring, 8
 - Removing Modules, 12
 - Reset, 2, 21



RESET, 20
RS-232, 22

S

Sensor, 1
 Cleaning, 25
 Fault, 24, 25
 Housing, 10
 LED's, 1
 Naming, 20
 Pinout, 27
 Replacement, 25
 Status, 1
 Wiring, 12
SENSOR FAULT, 24
SENSOR INIT FAULT, 24
Serial Number, 13, 14
Siren
 Chirp, 1, 2, 21
 Hush, 2, 20
 Wiring, 7
SOURCE FAULT, 24
Spectral Bands, 1
SS2 See Sensor:, 1
Static Damage, 5
SuperBus, 8, 22
SuperBus Power, 22

Swivel Mount, 10

T

Temperature, 25
Test Source, 1, 17, 21
 Cleaning, 25
 Fault, 24
 Housing, 10
 Location, 5
 Pinout, 27
 Replacement, 25
 Wiring, 12
Test Sources
 Additional, 19
 Adjusting angle, 19
Theory of Operation, 1
Troubleshooting, 23

U

UC2000, 3, 22
Ultraviolet (UV) Band, 1
UPS, 7

V

Visible Band, 1

Voting, 2, 17
 Changing configuration, 17
 Definition of, 19
 Initialization, 18

W

Weco
 Connector, 12
Window
 Contaminated, 21
 Dirty, 21
Windows
 Dirty, 17
 When to clean, 17
Wiring
 Shields, 12

Z

Zoning, 1, 17
 Changing configuration, 17
 Cross-Zoning, 1
 Initialization, 18
 Multilevel, 21



Thank you for reading this data sheet.

For pricing or for further information, please contact us at our UK Office, using the details below.



UK Office

Keison Products,

P.O. Box 2124, Chelmsford, Essex, CM1 3UP, England.

Tel: +44 (0)330 088 0560

Fax: +44 (0)1245 808399

Email: sales@keison.co.uk

Please note - Product designs and specifications are subject to change without notice. The user is responsible for determining the suitability of this product.