

INSTALLATION

- f. The earth bonding arrangement must ensure that the maximum peak voltage between the unit case earth and any field cable conductor is less than 350V. Voltages in excess of this can cause permanent damage to the unit's RFI protection filters.
- g. The use of a single, screened cable for each gas detector ensures maximum screening and minimum crosstalk. Cabling arrangements which use a single cable for connecting a number of field devices compromise screening, increase the potential for crosstalk and prevent implementation of true star earthing.
- h. Any electrical interference induced onto the 4 - 20mA loop conductors by the installation must be kept below the levels necessary to comply with the general requirements of EN 60079-29-1 & IEC 60079-29-1. In practice, this means that peak noise currents induced on the current loop should be no greater than ± 0.25mA
- j. The 0V rail of the control card/control system is directly connected to one side of the 4 - 20mA current sensing resistor. Electrical noise on this rail is therefore directly connected to the 4 - 20mA input. In order to avoid additional noise being induced on the 0V rail, it should not be commoned with the safety earth/ground, which frequently carries a high level of electrical noise.
- k. All electrical equipment connected to the gas detector should comply with EN61000-6-3 and EN61000-6-2.
- l. The 24V supply should be free from large transients and fluctuations.
- m. The field cabling conductors should have sufficient cross sectional area to ensure that the minimum supply voltage applied to the gas detector is 18V at a current of 420mA. This corresponds to a maximum round loop impedance of 14 ohms for a nominal 24V system supply.
- n. Receivers should not be installed in close proximity to the antennae of high powered radio, radar and satellite communication equipment.

11

INSTALLATION

4.3.2 Electrical Installation

1. Isolate all associated power supplies and ensure that they remain OFF during this procedure.
2. If the units are to be installed with junction boxes other than OELD or DX100(M) junction boxes, ensure that the boxes:
 - have M20 cable gland entries for ATEX / IECEx units, or 3/4 NPT for UL and CSA.
 - have terminals for 5 wires and an earth.
3. Remove the M20 blanking plugs (if fitted) and attach the Excel transmitter and receiver cables to their junction box. Fit the locking rings (if supplied) before terminating the cables in the junction box.
4. Fit approved cable glands to the junction box cable entries, using sealing washers where necessary to maintain the ingress protection rating.
5. Fit approved blanking plugs to all unused cable entries.
6. Make appropriate electrical connections as shown in the following diagrams.

4.3.3 Receiver Connections via OELD

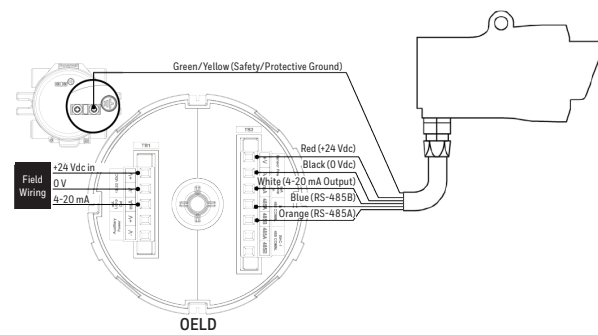

Note: Using metal cable glands will connect the screen of the cable to the Excel Body.

12

INSTALLATION

4.3.4 Receiver Connections via DX100(M)

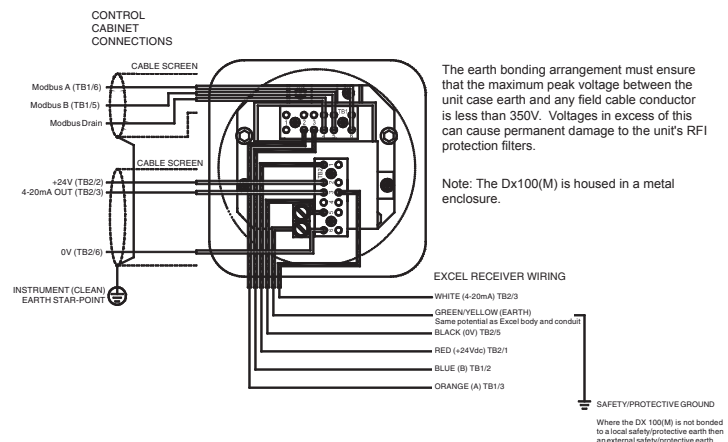

4.3.5 Transmitter Connections

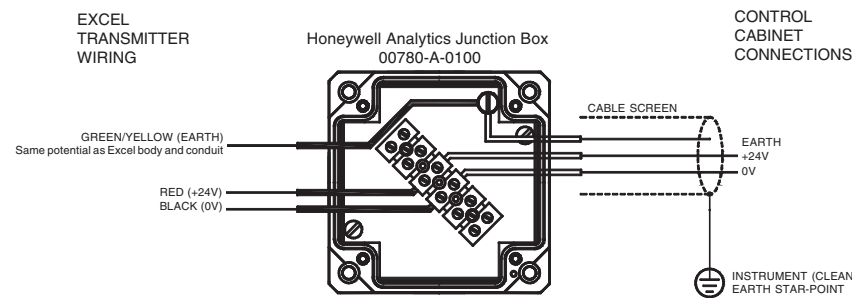

NOTE: FOR DNV VERSIONS, REFER TO THE SEARCHLINE EXCEL TECHNICAL HANDBOOK FOR SPECIAL INSTRUCTIONS ON THE INSTALLATION, ALIGNMENT AND COMMISSIONING USING THE MARITIME BRACKET AND HARDWARE

13

INSTALLATION

4.3.6 Remote Installation Receiver Connections

- 4.3.6.1 Remote installation via OELD - refer to Section 4.3.3
- 4.3.6.2 Remote installation via DX100(M)

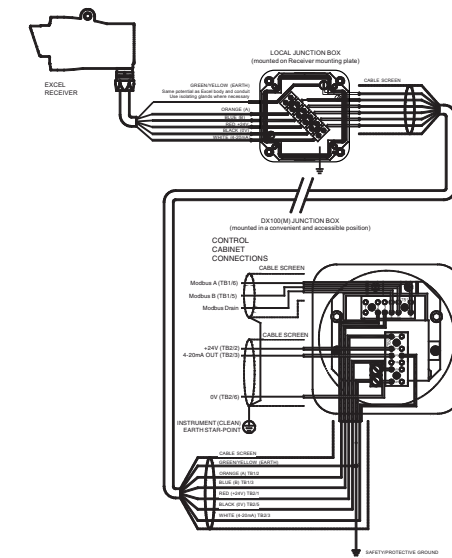

4.3.7 Transmitter Connections - Turbo Heating Disabled

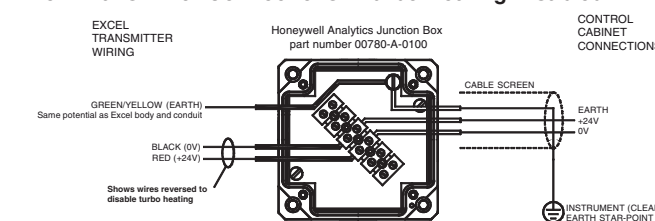

The earth bonding arrangement must ensure that the maximum peak voltage between the unit case earth and any field cable conductor is less than 350V. Voltages in excess of this can cause permanent damage to the unit's RFI protection filters.

14

Installation Guide

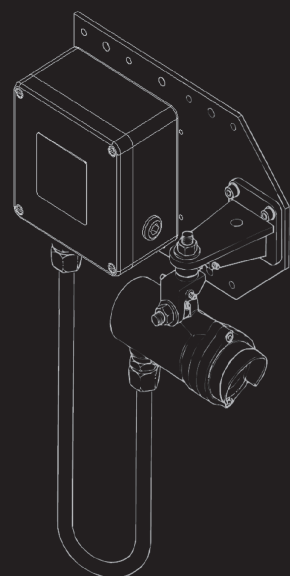

Searchline Excel Open Path Infrared Gas Detector

CONTENTS

1. Introduction	2
2. Safety	3
3. Mechanical assembly	4
3.1 General	4
3.2 Transmitter	4
3.3 Receiver	4
3.4 Adjustable Mountings	5
4. Installation	6
4.1 General	6
4.2 Mechanical Installation	6
4.3 Electrical Installation	10
4.3.1 Electrical Connections	10
4.3.2 Electrical Installation	12
4.3.3 Receiver Connections via OELD	12
4.3.4 Receiver Connections via DX100(M)	13
4.3.5 Transmitter Connections	13
4.3.6 Remote Installation Receiver Connections	14
4.3.7 Transmitter Connections - Turbo Heating Disabled	14

1. INTRODUCTION

This guide provides the installation personnel with the basic information necessary to mechanically install the Searchline Excel system units and make the necessary electrical connections.

This guide is not intended to replace the associated Searchline Excel Technical Handbook (2104M0506) which contains the full safety, installation, commissioning, maintenance and fault finding instructions.

These procedures assume that consideration of the location and mounting of the system units has already been taken into account in accordance with the guidelines in the Technical Handbook.

The following diagram shows a typical system configuration and identifies the main parts.

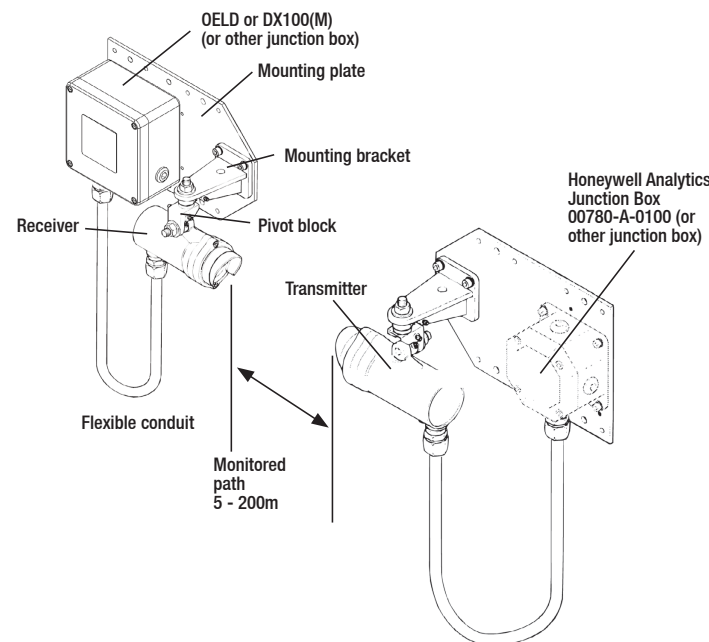

1

2



Issue 6 07/2017
MAN0558_EMEAI
2104M0510
© 2017 Honeywell Analytics

Please Note:
While every effort has been made to ensure accuracy in this publication, no responsibility can be accepted for errors or omissions. Data may change, as well as legislation and you are strongly advised to obtain copies of the most recently issued regulations, standards and guidelines. This publication is not intended to form the basis of a contract.

1106

2. SAFETY

Ensure that you read and understand these instructions **BEFORE** handling or operating the equipment. Please pay particular attention to the Safety Warnings.

WARNINGS

- The Searchline Excel gas detector is certified for and intended for use in potentially hazardous areas. Install and use the Searchline Excel gas detector in accordance with the latest regulations.
- For installations in the UK, the Code of Practice SELECTION, INSTALLATION AND MAINTENANCE OF ELECTRICAL APPARATUS FOR USE IN POTENTIALLY EXPLOSIVE ATMOSPHERES should be strictly observed. General recommendations are given in BS EN 60079-14 & IEC 60079-14. Refer to BS EN 60079-29-2 & IEC 60079-29-2 in the UK or the appropriate local or national regulations.
- For installations in North America, the national Electrical Code (NFPA 70) or later issues should be strictly observed.
- Elsewhere, the appropriate local or national regulations should be used.
- The Searchline Excel gas detector must be properly earthed to protect against electrical shock and minimise electrical interference. For electrical installation design considerations refer to Section 3.
- Operators must be fully aware of the action to be taken if the gas concentration exceeds an alarm level.
- Dismantling or repair of equipment should be carried out in the safe area only.
- Test gases may be toxic and/or combustible. Refer to Material Safety Sheets for appropriate warnings.
- Do not drill holes in any housing as this will invalidate the explosion protection.
- In order to maintain electrical safety, the unit must not be operated in atmospheres with more than 21% oxygen.
- Ensure that the bolts which secure flameproof enclosures are fully tightened. The securing bolts used are made from a special certified grade of steel. Only bolts supplied by Honeywell Analytics should be fitted for this purpose.
- Do not open the enclosure in the presence of an explosive atmosphere.
- The transmitter unit contains high voltages when operational. These are discharged when the unit is removed from its enclosure.
- The conduit and cable glands fitted to Searchline Excel should not be modified. If, however, it becomes necessary to make modifications they must comply with the relevant national Codes of Practice.
- The irradiance and power emitted by the Searchline Excel transmitters is less than 5 mW/mm² and 15 mW/mm² respectively.

Honeywell Analytics Limited reserve the right to change or revise the information supplied in this document without notice and without obligation to notify any person or organisation of such revision or change. If further details are required that do not appear in this document, contact Honeywell Analytics Limited or one of their agents.

3

3. MECHANICAL ASSEMBLY

3.1 GENERAL

This section details the mechanical assembly information and important dimensions necessary for installing the system units. Adjustable parts which form part of the mounting assemblies are also shown.

NOTE: FOR DNV VERSIONS, REFER TO THE SEARCHLINE EXCEL TECHNICAL HANDBOOK FOR SPECIAL INSTRUCTIONS ON THE INSTALLATION, ALIGNMENT AND COMMISSIONING USING THE MARITIME BRACKET AND HARDWARE

3.2 TRANSMITTER

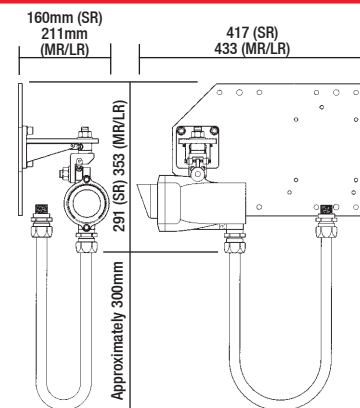

3.3 RECEIVER

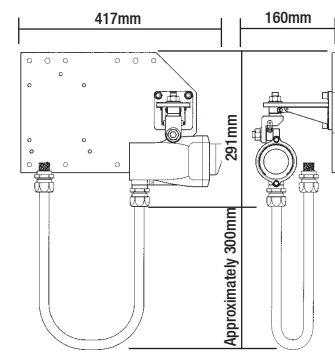

4

MECHANICAL ASSEMBLY

3.4 ADJUSTABLE MOUNTINGS

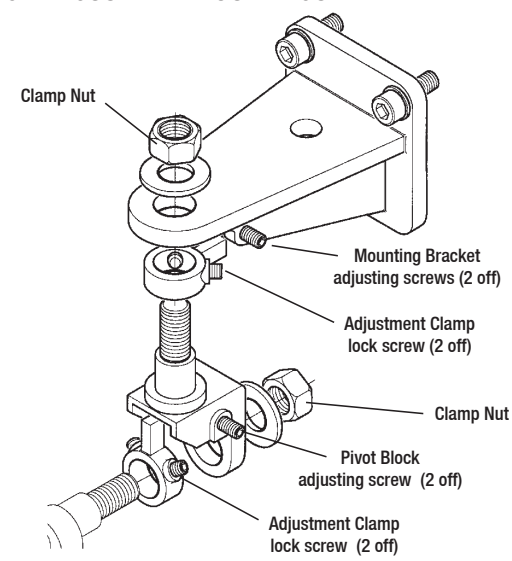

5

INSTALLATION

- Notes:
- Drawing is not to scale.*
 - Mounting plate fixing holes are clear. Searchline Excel system component mounting holes are threaded.

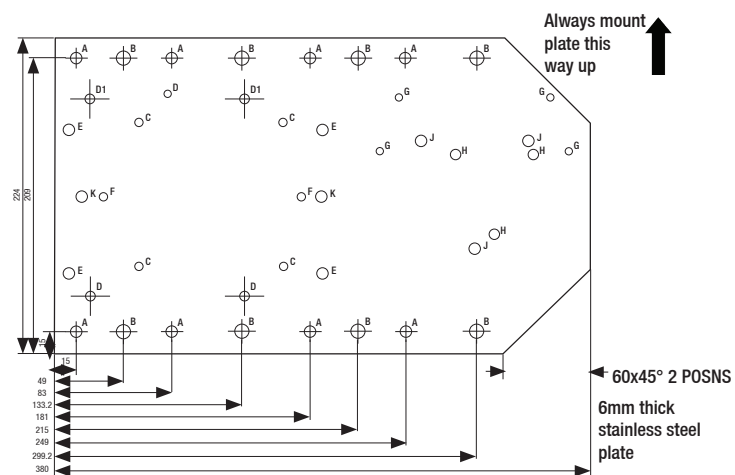

3. The mounting plate fixings are not supplied.

- Fit an adjustment clamp to the unit's pivot block mounting stud so that it sits on the stud's shoulder with the correct orientation as shown in the diagram.

7

INSTALLATION

Identity	Quantity	Size	Used For
A	8	ø7.5mm	Dual 2" pipe or pole mounting, flat surface mounting
B	8	ø9.5mm	Single 6" pole, flat surface mounting, Dual 2.5" ID pipe
C	4	M6 tapped	00780-A-0100 junction box mounting
D	3	M6 tapped	DVC100(M) junction box mounting.
D1	2	M6 tapped	DVC100(M) MK2 junction box (used in conjunction with bottom two D holes)
E	4	M10 tapped	DX100(M) junction box mounting
F	2	M6 tapped	Killark/Akron junction box mounting
G	4	M6 tapped	Sun/heat shade mounting
H	3	M8 tapped	Short range Transmitter and all Receiver brackets.
J	3	M10 tapped	Medium/Long range Transmitter mounting bracket.
K	2	M10 tapped	XNX Universal Transmitter

- Tighten the adjustment clamp's grub screws until they just grip the unthreaded part of the mounting stud.
 - Fit the pivot block to the mounting bracket using a clamp nut and spring washer (M12 or M16) with the correct orientation as shown in the diagram. Do not fully tighten the nut.
- Ensure that the adjustment clamp's stub lever is positioned approximately centrally between the mounting bracket's grub screws. Adjust the screws if required.

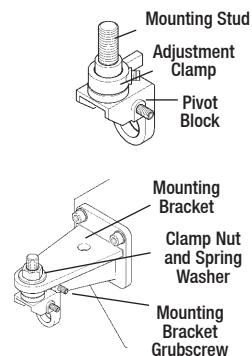

8

INSTALLATION

- Fit an adjustment clamp to the unit's pivot block mounting stud so that it sits on the stud's shoulder with the correct orientation as shown in the diagram.
- Tighten the adjustment clamp's grub screws until they just grip the unthreaded part of the unit's mounting stud.
- Fit the unit to the pivot block using a self-locking clamp nut and washer (M12 or M16). Do not fully tighten the nut.

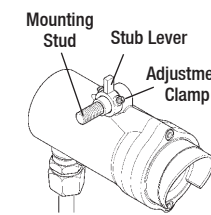

Ensure that the adjustment clamp's stub lever is approximately centrally positioned between the pivot block's grub screws. Adjust the screws if required.

- Fit a suitable junction box, e.g. OELD, DX100(M) or other suitable type of junction box, to the mounting plate

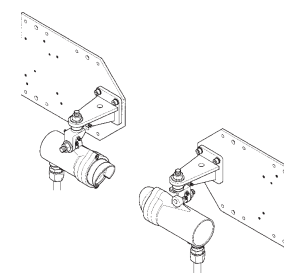

- Measure the distance (in metres) between the transmitter and receiver units.

This distance is required by the system commissioning personnel.

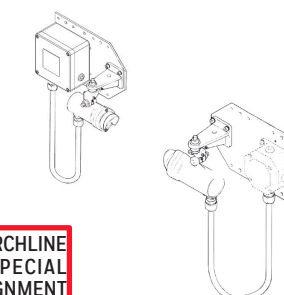

NOTE: FOR DNV VERSIONS, REFER TO THE SEARCHLINE EXCEL TECHNICAL HANDBOOK FOR SPECIAL INSTRUCTIONS ON THE INSTALLATION, ALIGNMENT AND COMMISSIONING USING THE MARITIME BRACKET AND HARDWARE

9

4. INSTALLATION

4.1 GENERAL

Searchline Excel is designed to allow installation to be performed by a single operator.

The installation procedure is split into mechanical installation and electrical installation. Each unit needs to be mounted to a supporting structure before making the electrical connections. The diagrams show different ways of orientation for the mountings.

4.2 MECHANICAL INSTALLATION

This mechanical installation procedure applies to both the receiver and the transmitter.

- Ensure that the equipment to be installed is correct for the type of installation required (i.e. short/medium/long range).
- Fit the mounting bracket to the mounting plate for the unit, as shown.
- Fit the mounting plate to the supporting structure in one of the following ways:

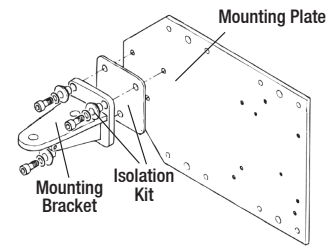

- by through bolts directly to a flat surface.
- by U-bolts (2 off) to a single 150mm diameter pipe/pole.
- by U-bolts (4 off) to two 55mm diameter pipes/poles, 166mm apart.

Identify the mounting holes using the following diagram and the accompanying table. The subsequent diagrams show the different types of mountings.

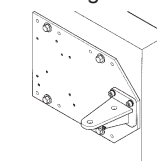

Surface Mounting

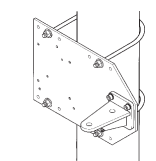

Single Pipe/Pole

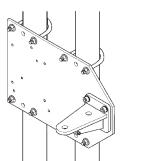

Dual Pipes/Poles

6

INSTALLATION

4.3 ELECTRICAL INSTALLATION

4.3.1 Electrical Connections

All ranges of Searchline Excel comply with the EMC requirements EN50270. In order to maintain compliance with these standards it is essential that the electrical installation of Excel is engineered correctly.

Electrical installation standards vary for different countries, companies and applications and it is the responsibility of the installation design authority to determine the applicable standards and ensure compliance with them. When designing electrical installations for Excel, Honeywell Analytics Limited recommend that the installation design authority considers the following:

- The unit cases should not, if possible, be connected to electrically noisy (dirty) metalwork or conductors. Preferably, the case (internally connected to the green/yellow GND wire) should be connected to a low noise instrument (clean) earth. See also para e. below. In order to facilitate electrical isolation of the Searchline Excel from a noisy earth an isolation kit is supplied. This kit should be fitted as standard unless local regulations forbid this.
- The entire length of the field cabling connected to each unit should be fully shielded. This should be connected to a low noise (clean) earth.
- The low noise instrument (clean) earth system should only be connected to safety earth (usually dirty) at a single point on the entire site/installation. This connection should be made in such a manner that it does not introduce noise onto the low noise instrument earth. Star earthing arrangements minimise earth current crosstalk.
- The shields of the field cabling should not be connected such that earth loops are produced, or in a manner that will result in the shields carrying large currents from heavy plant or equipment.
- Ideally, the field cable shield should be connected to the unit's green/yellow GND wire, providing a single, continuous earth shield. This connection must not be allowed to complete an earth loop.

10