

**Model 4510
Conductivity/TDS Meter
Operating Manual**

SAFETY

Please read this information carefully prior to installing or using this equipment.

1. The unit described in this manual is designed to be operated only by trained personnel. Any adjustments, maintenance and repair must be carried out as defined in this manual, by a person qualified to be aware of the hazards involved.
2. It is essential that both operating and service personnel employ a safe system of work, in addition to the detailed instructions specified in this manual.
3. References should always be made to the Health and Safety data supplied with any chemicals used. Generally accepted laboratory procedures for safe handling of chemicals should be employed.
4. If it is suspected that safety protection has been impaired in any way, the unit must be made inoperative and secured against any intended operation. The fault condition should immediately be reported to the appropriate servicing authority.

**Model 4510
Conductivity/TDS Meter
Operating Manual**

Contents

Section 1	Introduction	
	Instrument Description	1.1
	Instrument Specification	1.2
Section 2	Installation	
	Unpacking	2.1
	Installation	2.2
	Displays	2.3
	Controls	2.4
	Inputs/Outputs	2.5
Section 3	Operation	
	Good Practice Guidelines	3.1
	Instrument Set up	3.2
	Preparation of Standards	3.3
	Calibration:	
	With Known Cell Constant	3.4
	With Standard Solution	3.5
	Sample Measurement	3.6
Section 4	Maintenance	
	General	4.1
Section 5	Optional Accessories	
	Optional Accessories	5.1
	Spares	5.2
Section 6	Interfacing	
	Analogue	6.1
	RS232	6.2
	Keypad Emulation	6.3
	Printing	6.4
Section 7	Troubleshooting	
k	Troubleshooting	7.1

Section 1

Introduction

1.1 Instrument Description

A general purpose Conductivity/TDS/temperature bench meter for use in laboratory situations. The instrument includes a 32 reading memory facility. Features include: automatic range selection, calibration on standard solutions or direct cell constant entry, automatic temperature compensation, analogue output and RS232 serial interface.

1.2 Instrument Specifications

Conductivity

Ranges	0 to 19.99 μ S / 0 to 199.9 μ S / 0 to 1999 μ S / 0 to 19.99mS / 0 to 199.9mS / 0 to 1999mS
Resolution	0.01 μ S / 0.1 μ S / 1 μ S / 0.01mS / 0.1mS / 1mS* *only with cell constant >5
Accuracy	$\pm 0.5\% \pm 2$ digits

TDS

Ranges	0 to 19.99mg/l / 0 to 199.9mg/l / 0 to 1999mg/l / 0 to 19.99g/l / 0 to 199.9g/l / 0 to 1999g/l
Resolution	0.01mg/l / 0.1mg/l / 1mg/l / 0.01g/l / 0.1g/l / 1g/l* *only with cell constant >5
Accuracy	$\pm 0.5\% \pm 2$ digits

Temperature

Range	-10 to +105°C (14 to 221°F)
Resolution	0.1°C (1°F)
Accuracy	$\pm 0.5^\circ\text{C}$ ($\pm 1^\circ\text{F}$)
ATC Range	0 to 100°C (32 to 212°F)
Manual Temp. Comp. Range	0 to 100°C (32 to 212°F)
Display	3½ digit LCD
Power	9V power supply
Size	210x250x55mm
Weight	850g

Section 2

Installation

2.1 Unpacking

Remove the Model 4510 from the packaging and ensure the following items are included:

1. Model 4510 Conductivity/TDS Meter
2. Glass bodied conductivity cell with ATC K=1 (027 013)
3. Electrode holder
4. Power Supply (as specified at time of ordering the product)
5. Condensed operating instructions (451 051)
6. Operating Manual (451 050)

The electrode stand requires minimal assembly (refer to the diagram below)

Any shortages or damage should be reported immediately to the manufacturer or your local distributor.

2.2 Installation

The Model 4510 is supplied ready to use. Connect the conductivity cell to the rear panel DIN socket.

The electrode stand requires minimal assembly (refer to the diagram below).

Fig. 2.2.1 Electrode Holder Assembly

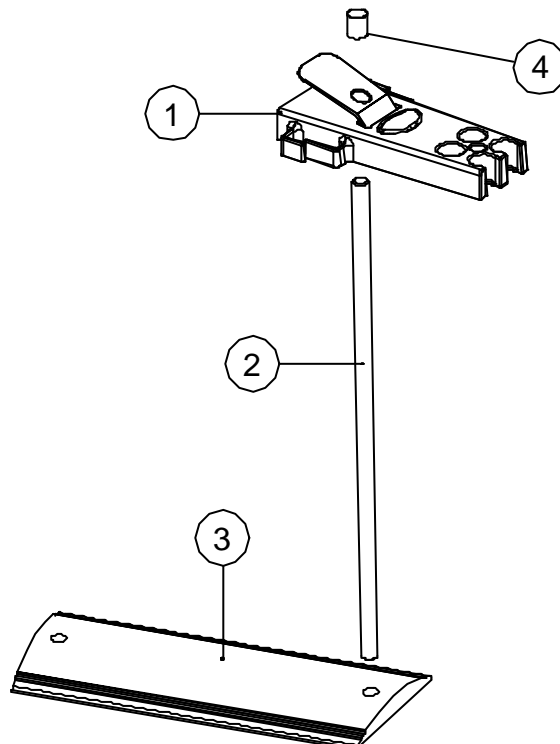

2.3 Displays

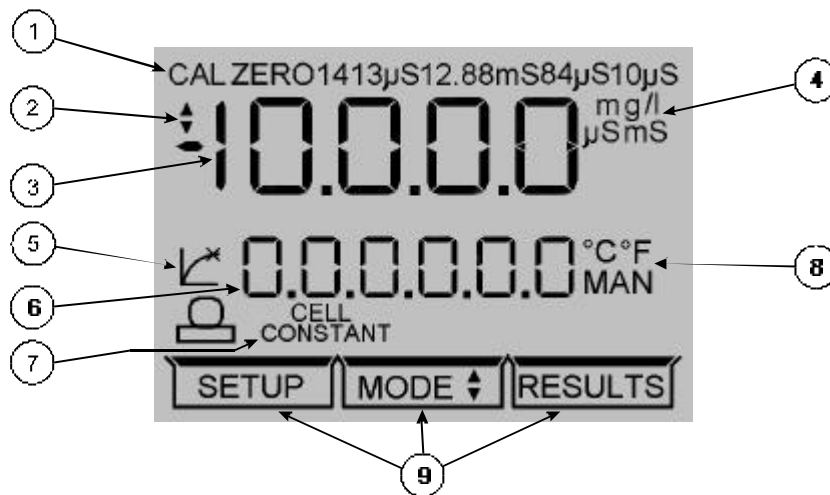

1. Standard selection – indicates which type of standard is being used. Also indicates when a calibration is being performed.
2. Symbol – displayed during set-up of instrument parameters.
3. Primary display – 4½ digit. Provides direct readout in Conductivity or TDS of samples and standards.
4. Mode annunciators – shows selected measurement mode; Conductivity (μS or mS) and TDS (mg/l or g/l).
5. Endpoint symbol
6. Secondary display – 6 digit display. Provides direct readout of automatic or manual temperature. Scrolls and displays selected parameter information in set-up mode.
7. Status display – 2½ digit.
8. Mode annunciators – indicates temperature in $^{\circ}\text{C}$ or $^{\circ}\text{F}$ and whether the measurements are manually or automatically temperature compensated.
9. Mode tags – Each mode tag is highlighted when selected; SETUP, MODE or RESULTS.

2.4 Keypad

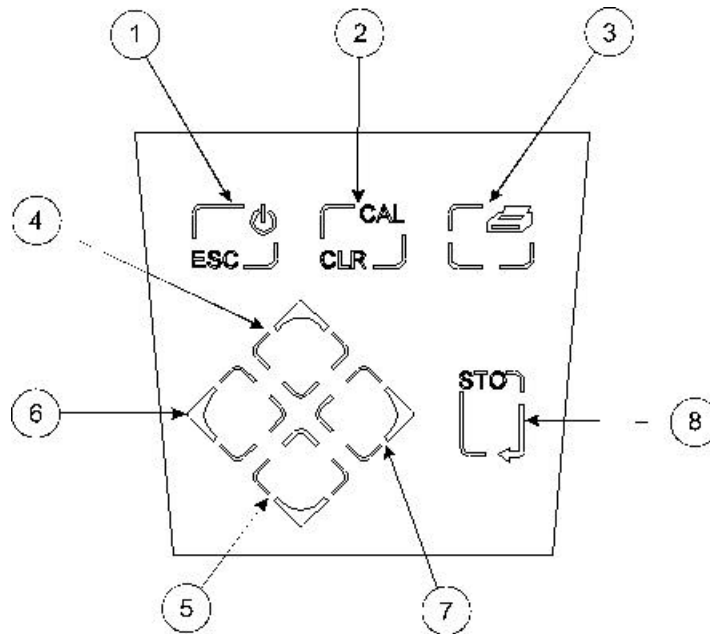

1. ESC used to switch the instrument on and to place into standby mode (only if power supply lead remains connected to the instrument). Also used to escape/exit a mode.
2. CAL / CLR used to select and perform a calibration sequence. This key is also used to clear readings from Memory.
3. Print key used to initiate a print.
4. Up Arrow used for adjustment during set up, to scroll results and to toggle between Conductivity (μS or mS) and TDS (mg/l or g/l) modes.
5. Down Arrow used for adjustment during set up, to scroll results and to toggle between Conductivity μS or mS) and TDS (mg/l or g/l) modes.
6. Left Arrow used for adjustment during set up and to move between mode tags.
7. Right Arrow used for adjustment during set up and to move between mode tags.
8. STO used to accept an entered value in set-up mode and to instigate a stored reading. This key can also be used as a CAL key during calibration.

2.5 Inputs/Outputs

2.5.1 Rear panel layout

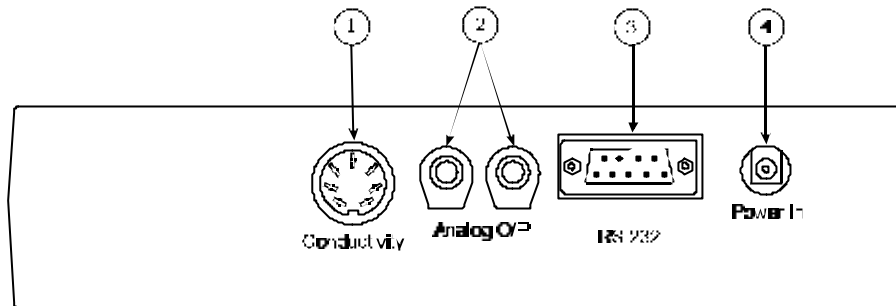

- | | |
|------------------------|---|
| 1. Conductivity Socket | 7 pin DIN socket which allows the conductivity cell to be connected. |
| 2. Analog Out | 2 x 4mm sockets. Analogue output (buffered electrode potential). |
| 3. Output Socket | 9 way socket for RS232 connection. |
| 4. Power In | AC 9V I/P socket. 2.1 x 5.5mm socket allowing the power supply to be connected to the instrument. |

Section 3

Operation

3.1 Good Practice Guidelines

1. For greatest accuracy ensure no particulate matter is suspended in the solution under test. If necessary, filter or allow the particles to settle prior to use. Do not allow the cell to come into contact with any sediment which may be present.
2. Ensure no air bubbles are trapped in the cell area between the plates.
3. Ensure the cell plates are completely immersed in the solution under test.
4. Thoroughly rinse the cell plates in deionised water after use, and for short term storage immerse the cell in deionised water. Although it is not essential to store the conductivity cell with the plates in a wetted condition, if they are allowed to dry out completely, initial stability on re-use may be impaired until the cell plates become re-wetted.
5. Do not attempt to clean the cell plates as this will remove the black platinization and alter the calibration and accuracy of the probe. If the cell plates become worn or damaged the plates should be re-platinised and the cell constant recalculated.
6. Ensure no salt deposits or particulate matter are allowed to build up around the cell plates or on the probe body as this may produce a conductivity path lower than that through the solution. It is recommended that such deposits be removed by soaking the cell in deionised water. No attempt should be made to wipe off these deposits as this may cause damage to the cell plates.
7. Ensure the correct reference temperature is selected for the operating procedures being used.

3.2 Instrument Set-Up

The following section details the set-up modes available to the user.

These are: Cell constant, Coefficient, Reference Temperature, TDS EC Ratio, Temperature units and Baud Rate. These can be set in sequence as detailed in this section or, by entering the SET UP mode and using the STO key to select a specific parameter at any time.

To exit the set up menus at any time press the ESC key. This will return the instrument to the MODE menu. Any parameters not saved will remain as defaults or previous setting.

3.2.1 Cell Constant (K) entry

Select SETUP mode on the display using the Left arrow key.



The secondary display will show CELL K and will then scroll CELL CONSTANT after 10 seconds.

Symbol  will flash while adjustment is being made.

The first digit of the displayed value will be flashing. Adjustment of the flashing digit can be made using the Up/Down arrow keys.

The Left/Right arrow keys are used to select the next adjusting digit which will flash when selected.

Once the full reading has been adjusted to the required value, press the STO key. The symbol will disappear and the secondary display will momentarily show SAVED. The instrument display will update and then show the Coefficient set up menu.

3.2.2 Temperature Coefficient set up

The display will show:



The secondary display will show COEFF and will then scroll TEMPERATURE COEFFICIENT after 10 seconds.

Symbol  will flash while adjustment is being made.

The first digit of the displayed value will be flashing. Adjustment of the flashing digit can be made using the Up/Down arrow keys.

The Left/Right arrow keys are used to select the next adjusting digit which will flash when selected.

Once the full reading has been adjusted to the required value, press the STO key. The symbol will disappear and the secondary display will momentarily show SAVED. The instrument display will update and then show the Reference Temperature set up menu.

3.2.3 Reference Temperature selection

The display will show:



The secondary display will show REF T and will then scroll REFERENCE TEMPERATURE after 10 seconds. Select the reference temperature from the options available (18, 20 or 25°C) by scrolling through the list using the Up/Down arrows.

Symbol  will flash while adjustment is being made.

The Left/Right arrow keys and the CAL/CLR key have no function during this set up.

To accept the correct reference temperature value, press the STO key. The symbol will disappear and the secondary display will momentarily show SAVED. The instrument display will update and then show the TDS EC ratio set up menu.

3.2.4 TDS EC Ratio

The display will show:



The secondary display will show TDS EC and will then scroll TDS EC RATIO after 10 seconds.

Symbol  will flash while adjustment is being made.

The first digit of the displayed value will be flashing. Adjustment of the flashing digit can be made using the Up/Down arrow keys.

The Left/Right arrow keys are used to select the next adjusting digit which will flash when selected.

Once the full reading has been adjusted to the required value, press the STO key. The symbol will disappear and the secondary display will momentarily show SAVED. The instrument display will update and then show the Temperature Units set up menu.

3.2.5 Temperature Units selection

The display will show:



The secondary display will show UNITS and will then scroll TEMPERATURE UNITS after 10 seconds. Select the preferred temperature unit from the options available (°C or °F). The Up/Down arrows toggle between the units.

Symbol  will flash while adjustment is being made.

The Left/Right arrow keys and the CAL/CLR key have no function during this set up.

To accept the preferred temperature unit, press the STO key. The symbol will disappear and the secondary display will momentarily show SAVED. The instrument display will update and then show the Baud Rate set up menu.

3.2.6 Baud Rate

For full details relating to serial protocol refer to Section 6 of this manual.

The display will show:



The secondary display will show BAUD and will then scroll SERIAL PORT BAUD RATE after 10 seconds.

Select the required baud rate (9600 or 1200) using the Up/Down keys which toggle between the values. The data bits and parity will automatically adjust as the baud rate is selected.

The Left/Right arrow keys and the CAL/CLR key have no function during this set up.

Symbol  will flash while adjustment is being made.

To accept the selected baud rate, press the STO key. The symbol will disappear and the secondary display will momentarily show SAVED and the instrument will return to the MODE menu.

3.3 Preparation of Conductivity Standards

Suitable conductivity standards are available commercially or these can be made up as required from analytical grade reagents with reference to relevant physical tables.

Method for general purpose Conductivity Standard

Accurately weigh out 0.746 grammes of dried A.R. grade Potassium Chloride (KCl) and dissolve in 1 litre of good quality water. This produces a 0.01N solution with a conductivity of 1413 μ S at 25°C.

Storage

This solution must be stored in a plastic container and the air space above the solution should be kept to an absolute minimum. The shelf life of 1 week can be increased by storing below 4°C, but where any doubt exists about the viability of stored solution a fresh batch should be prepared.

3.4 Calibration with Known Cell Constant

1. Connect a standard pre-calibrated cell to the unit.
2. Select SETUP mode on the display using the Left arrow key.
3. Set the cell constant value as indicated on the body of the conductivity cell (refer Section 3.2.1)

The standard X1.0 cell has a cell constant range from 0.8 to 1.20 and is generally calibrated to 2 decimal places. The display should be set to indicate this figure exactly.

The X10 cell has a cell constant range from 8.0 to 12.0 and is generally calibrated to 2 decimal places. The display should be set to indicate this figure.

4. Set the Temperature Coefficient value (refer Section 3.2.2).
5. Select the required reference temperature (refer Section 3.2.3).

3.5 Calibration with Standard Solution

Calibration of the unit and cell with standard solutions will only be necessary if:

- 1) The cell constant is unknown.
- 2) The cell constant has changed due to replatinising, wear or damage to the plates.
- 3) An ATC slope other than 2%/°C is required (refer Special Calibration).

General Calibration

- 1) Immerse the conductivity cell into the prepared standard.
- 2) Select the MODE menu using the keypad.
- 3) Press the CAL/CLR key. The unit will calibrate to the nearest standard.

3.6 Sample Measurement

General

Conductivity is a temperature dependent measurement. All substances have a conductivity coefficient which varies from 1% per °C to 3% per °C for most commonly occurring substances. The automatic temperature compensation on the 4510 defaults to 1.91% per °C, this being adequate for most routine determinations.

Conductivity readings varying with temperature may be due to the substances under test having a coefficient other than the typical value of 1.91% per °C. To eliminate this variation it is necessary to maintain all samples at the reference temperature by use of a thermostatic water bath or equivalent.

Adjustment may be made by entering the SETUP menu and selecting COEFF (refer Section 3.2.2). The reading can then be adjusted to the required value (0.00 to 4.00) by using the keypad.

Sample Measurement

After calibration the measurement of samples is carried out by immersing the cell in the samples, allowing the readout to stabilise, and recording the result. The cell should be rinsed in deionised water between each sample to avoid contamination, shaken to remove internal droplets, and the outside wiped prior to immersion in the next sample.

On completion of sample measurement the cell should be thoroughly rinsed in deionised water.

Storage

Short Term	the cell should be immersed in deionised water to keep the plates wetted.
Long Term	the cell should be thoroughly rinsed in deionised water, the exterior body wiped and then stored dry.

NOTE: When preparing the cell for storage the plate area MUST NOT be wiped dry. When using a dry cell initial stability on re-use may be impaired until the cell plates become re-wetted.

To obtain optimum performance refer to Section 3.1 - Good Practice Guidelines.

3.7 Results storage and display

To store the current displayed result press the STO key. The instrument display will momentarily show STORED on the secondary display. The memory location will be given on the status display.

Up to 32 results can be stored. Each result will be stored in the next available memory location.

The instrument will store:

- Primary Conductivity or TDS readings
- Temperature readings and the unit of measurement (°C or °F)
- MAN if manual temperature measurement is used
- Endpoint symbol

Selecting the RESULTS menu displays the reading stored at the displayed memory location.



The Up arrow increments the memory index, the Down arrow decrements the memory index.

The Left arrow exits to the main measurement display.

The Right arrow and STO keys do not function.

CAL/CLR deletes the current memory location. The secondary display scrolls DELETED.

To exit this mode press the ESC key.

If the memory is full the secondary display will show FULL.

Section 4

Maintenance

4.1 General

The Model 4510 is designed to give optimum performance with minimum maintenance. It is only necessary to keep the external surfaces clean and free from dust. To give added protection when the unit is not in use the unit should be disconnected from the mains supply and covered with the optional dust cover (060 406). For longer term storage or re-shipment it is recommended that the unit be returned to the original packing case.

All conductivity cells should be thoroughly rinsed after use and stored in deionised water. Do not attempt to clean the surface of the plates as this could result in damage to the black platinised surface.

Section 5

Optional Accessories

5.1 Optional Accessories

060 406	Dust cover
037 701	Printer supplied with roll of thermal paper, serial connection lead, power supply, power connection lead (UK) and pouch
037 801	Interface cable kit
050 002	Serial communication software (3½" disk)

Conductivity Cells

027 113	Conductivity Cell K=0.1
027 114	Conductivity Cell K=1 (plastic covered)

NOTE: The cells listed below are glass free and epoxy bodied.

027 211	Conductivity Cell with ATC K=0.1
027 212	Conductivity Cell with ATC K=1
027 213	Conductivity Cell with ATC K=10

Calibration Standards

025 138	1413µS Standard (500ml)
025 156	12.88mS Standard (500ml)
025 164	84µS Standard (500ml)
025 139	10µS Standard (500ml)
025 165	1382ppm TDS Standard (500ml)

5.2 Spares

027 013	Conductivity Cell K=1
037 702	Paper roll, thermal
021 030	UK 230V power supply
021 031	European 230V power supply
021 032	US 115V power supply
021 033	230V leaded power supply

Section 6

Interfacing

6.1 Analogue

All units are provided with 2 x 4mm sockets, marked as ANALOG OUT, on the rear panel. An analogue output voltage of 1mV per least significant displayed digit is available from these sockets.

6.2 RS232

The Bi-directional RS232 interface is available on the rear panel 9 way D type connector. The connections are as follows:

DCD 1	- LINKED TO DTR AND DSR
RXD 2	- INPUT TO 4510
TXD 3	- OUTPUT FROM 4510
DTR 4	- LINKED TO DCD AND DSR
GND 5	
DSR 6	- LINKED TO DCD AND DTR
RTS 7	- OUTPUT FROM 4510
CTS 8	- INPUT TO 4510

Suggested interconnections are detailed below:

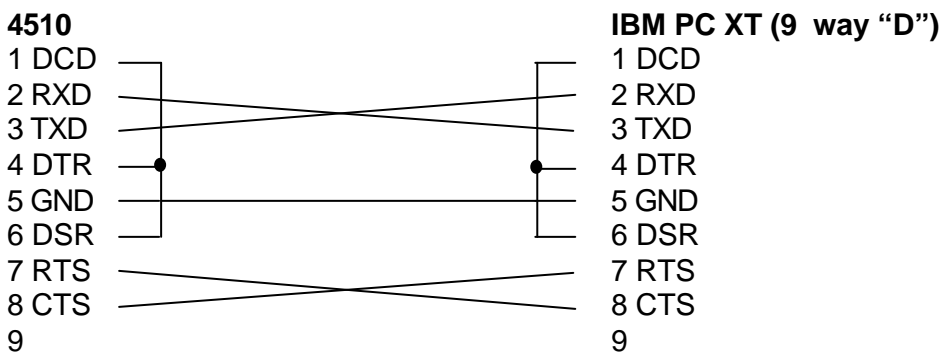
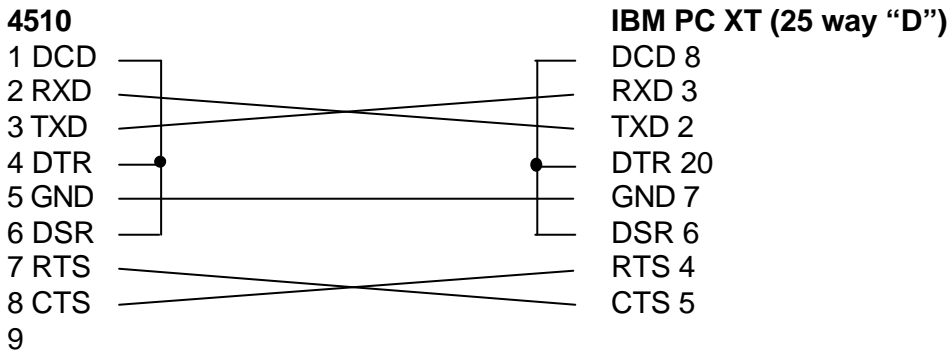

NOTE: Interface Cable (Order Code: 013 203) is required.

Interfacing (continued)

The RS232 communications parameters on the computer or printer need to be set to match those of the Model 4510, as detailed below:

1200 Baud		9600 Baud
7 Data Bits		8 data bits
Odd Parity	OR	No parity
1 Stop Bit		1 stop bit

Setting of these options is detailed in Section 3.6.6.

The Model 4510 supports both hardware (CTS/RTS) flow control and software XON/XOFF flow control.

Pressing the PRINT key outputs from the RS232 interface.

Sending an ASCII "D" to the 4510 causes a printout of the current displayed reading plus sample number.

Sending an ASCII "C" causes a printout of the last calibration parameters.

Sending an ASCII "P" causes a printout of the stored readings.

6.3 Keypad Emulation

Keypad remote control using RS232 interface:

7	- Instrument On / Standby / Escape
1	- Calibrate / Memory Clear
9	- Print
8	- Up Arrow
2	- Down Arrow
4	- Left Arrow
6	- Right Arrow
3 or 5	- Enter / Store

6.4 Printing

A 32 column serial printer (037 701) is available for use with the Model 4510.

Connect the printer via the cable supplied with the printer to the 9 way socket located on the rear panel of the instrument.

To initiate a print out of data press the print key.

When the first print is performed a header section will be printed showing:

- Instrument name
- Spacing for entry of Operator & User ID
- Most recent calibration information (Cell Constant)
- Reference temperature
- Temperature coefficient
- TDS EC ratio

This will be followed by results data in either $\mu\text{S} / \text{mS}$ (Conductivity) or $\text{mg/l} / \text{g/l}$ (TDS) dependent on mode selected. Details will also be given on temperature.

An asterisk (*) after the sample number indicates that an endpoint has been reached.

Each reading will be numbered sequentially.

A calibration will reset the data number to 0001 and the header information will be re-printed.

To obtain a print out of stored readings, enter the RESULTS MODE and press the print key. A print out of all 32 print locations will then be generated.

6.4.1 Example Printout

4510 Header printout

```

=====
4510 Conductivity Meter

Operator.. AN OTHER.....
User ID... OTH 123.....
Cell Constant   = 1.000
Reference Temp  = 25°C
Temp Coefficient = 1.91%
TDS EC Ratio   = 0.60%

=====
0001    0.01uS    * 25.0°C
0002 * 0.01uS    * 25.0°C
0003 * 0.01uS    * 25.0°C
0004 * 0.01uS    * 25.0°C
0005 * 0.01uS    * 25.0°C
0006 * 0.01uS    * 25.0°C
0007 * 0.01uS    * 25.0°C
0008 * 0.01uS    * 25.0°C
0009 * 0.01uS    * 25.0°C
0010 * 0.01uS    * 25.0°C
0011 * 0.01uS    * 25.0°C

```

4510 Results printout

```

=====
4510 Stored Results
=====
0001    0.01uS    28.1°C
0002    0.00uS    22.7°C
0003    0.00uS     77°F
0004    1422uS    22.3°C
0005 -> No Record <-
0006 -> No Record <-
0007 -> No Record <-
0008 -> No Record <-
0009 -> No Record <-
0010 -> No Record <-
0011 -> No Record <-
0012 -> No Record <-
0013 -> No Record <-
0014 -> No Record <-
0015 -> No Record <-
0016 -> No Record <-
0017 -> No Record <-
0018 -> No Record <-
0019 -> No Record <-
0020 -> No Record <-
0021 -> No Record <-
0022 -> No Record <-
0023 -> No Record <-
0024 -> No Record <-
0025 -> No Record <-
0026 -> No Record <-
0027 -> No Record <-
0028 -> No Record <-
0029 -> No Record <-
0030 -> No Record <-
0031 -> No Record <-
0032 -> No Record <-
=====

```

Section 7

Troubleshooting

7.1 Troubleshooting

Fault	Possible Cause	Action
No display	Check power supply	Check that correct 9V ac power supply is connected and switched on.
Erratic display	Check power supply	Unit must be used with supplied 9V ac power supply. Usage of other units will cause the 4510 not to operate.
Unstable display	Conductivity cell defective	Replace conductivity cell.
Display permanently under or over range	Intermittent or no connection Conductivity cell defective Contaminated solutions	Check cell connection to 4510. Replace conductivity cell Replace solutions
Intermittent display	Conductivity cell not fitted correctly	Check connections.
Reading drifts	Conductivity cell stored dry CO ₂ absorption by sample	Allow to soak for 2 hours Noticeable for low conductivity - do not allow sample to stand in unstoppered bottles.
Non linear readings	Conductivity cell not zeroed	Zero conductivity cell.
Poor reproducibility	Carryover between solutions	Rinse cell in distilled water between measurements.
Will not print	Connection Paper out Battery flat	4510 requires the RS232 cable to connect the printer. The feed light on the printer will flash if the unit requires paper. Connect ac power supply.

EC Declaration of Conformity

JENWAY Model 4510 Conductivity/TDS Meter complies with the following European Standards:

EN 50081-1:1992 Electromagnetic compatibility - Generic emission standard

EN 50082-1:1992 Electromagnetic compatibility - Generic immunity standard (Performance criterion B)

EN 61010-1:2001 Safety requirements for electrical equipment for measurement, control and laboratory use

Following the provision of:

EMC Directive - 89/336/EEC and Low Voltage Directive - 73/23/EEC



Thank you for reading this data sheet.

For pricing or for further information, please contact us at our UK Office, using the details below.



UK Office

Keison Products,

P.O. Box 2124, Chelmsford, Essex, CM1 3UP, England.

Tel: +44 (0)330 088 0560

Fax: +44 (0)1245 808399

Email: sales@keison.co.uk

Please note - Product designs and specifications are subject to change without notice. The user is responsible for determining the suitability of this product.