



- Detection of toxic gases or oxygen
- Interchangeable and pre-calibrated sensor modules
- Local display (optional)
- Durable in harsh environments
- Up to 5 years of life for O2 sensor

PRESENTATION

The CTX 300 can detect O₂, CO₂, toxic and refrigerant gases. Tyco Gas & Flame Detection offers a detector version with a wide range of sensors (infrared, electrochemical, semiconductor) according to your application needs. It is also available with or without display.

Simplicity

Sensor replacement does not require any special menu access. Just replace the sensor without even powering down the transmitter!

Reduced maintenance

As the only consumable element, the CTX 300 sensor is easily replaceable. New sensors come pre-calibrated from the factory. So during the sensor ex-change, no calibration gas is required, nor adjustments to the detector, or remote central controller are required.

3M™ Oldham CTX 300

Transmitter

Gas	Part Number	Type of sensor	Range (ppm)	Operating temperature	Relative humidity uncondensed
O ₂	WC3oO2F	Electrochemical	30.0 %	-20 °C to +50 °C	10 % to 95 % RH
	WC30O2G		30.0 % ❄️	-40 °C to +50 °C	10 % to 95 % RH
	WC3AO2G		30.0 %	-20 °C to +50 °C	10 % to 95 % RH
CO	WC3oO2S	Electrochemical	100 %	+5 °C to +40 °C	10 % to 95 % RH
	WC3oCOA		100	-20 °C to +50 °C	10 % to 95 % RH
	WC3oCOB		300	-20 °C to +50 °C	10 % to 95 % RH
	WC3oCOC		1000	-20 °C to +50 °C	10 % to 95 % RH
	WC3oCOD		1.00 %	-20 °C to +50 °C	10 % to 95 % RH
CO ₂	WC3oCOE	Infrared	10.0 %	-20 °C to +50 °C	10 % to 95 % RH
	WC3oCO2A		0.50%	-40 °C to +50 °C	0 % to 95 % RH
	WC3oCO2B		5.00 % ❄️	-40 °C to +50 °C	0 % to 95 % RH
H ₂ S	WC3oCO2C	Electrochemical	100 %	-40 °C to +50 °C	0 % to 95 % RH
	WC3oHSA		30.0	-20 °C to +50 °C	10 % to 95 % RH
	WC3oHSB		100	-20 °C to +50 °C	10 % to 95 % RH
NO	WC3oHSC	Electrochemical	1000	-20 °C to +50 °C	10 % to 95 % RH
	WC3oNOA		100	-20 °C to +50 °C	10 % to 95 % RH
	WC3oNOB		300	-20 °C to +50 °C	10 % to 95 % RH
NO ₂	WC3oNOC	Electrochemical	1000	-20 °C to +50 °C	10 % to 95 % RH
	WC3oN2A		10.0	-20 °C to +50 °C	10 % to 95 % RH
	WC3oN2B		30.0	-20 °C to +50 °C	10 % to 95 % RH
SO ₂	WC3oSOA	Electrochemical	10.0	-20 °C to +50 °C	10 % to 95 % RH
	WC3oSOB		30.0	-20 °C to +50 °C	10 % to 95 % RH
	WC3oSOC		100	-20 °C to +50 °C	10 % to 95 % RH
Cl ₂	WC3oCL2	Electrochemical	10.0	-20 °C to +50 °C	10 % to 95 % RH
H ₂	WC3oH2A	Electrochemical	2000	-20 °C to +50 °C	10 % to 95 % RH
	WC3oH2B		2 %	-20 °C to +50 °C	10 % to 95 % RH
HCl	WC3oHLA	Electrochemical	30.0	-20 °C to +50 °C	10 % to 95 % RH
	WC3oHLB		100	-20 °C to +50 °C	10 % to 95 % RH
HCN	WC3oHNA	Electrochemical	10.0	-20 °C to +50 °C	10 % to 95 % RH
	WC3oHNB		30.0	-20 °C to +50 °C	10 % to 95 % RH
NH ₃	WC3oNH3	Electrochemical	100	-20 °C to +40 °C	10 % to 95 % RH
	WC30NH3F		100 ❄️	-40 °C to +40 °C	10 % to 95 % RH
	WC3oNH1		1000	-20 °C to +40 °C	10 % to 95 % RH
	WC30NH2		5000	-20 °C to +40 °C	10 % to 95 % RH
ETO/PO	WC3oOET	Electrochemical	30.0	-20 °C to +50 °C	10 % to 95 % RH
HF	WC3oHFA	Electrochemical	10.0	-10 °C to +30 °C	10 % to 95 % RH
O ₃	WC3oO3A	Electrochemical	1.00	-20 °C to +50 °C	10 % to 95 % RH
PH ₃	WC3oPH3	Electrochemical	1.00	-20 °C to +50 °C	10 % to 95 % RH
ClO ₂	WC3oCLO	Electrochemical	3.00	-20 °C to +50 °C	10 % to 95 % RH
COCl ₂	WC3oCCL	Electrochemical	3.00	-20 °C to +40 °C	10 % to 95 % RH
Methylene chloride	CTX300-507	Semiconductor	500	-20 °C to +55 °C	10 % to 95 % RH
Methyl chloride	CTX300-508	Semiconductor	500	-20 °C to +60 °C	10 % to 95 % RH
Toluene	CTX300-652	Semiconductor	2000	-20 °C to +50 °C	10 % to 95 % RH
	CTX300-657		500	-20 °C to +50 °C	10 % to 95 % RH
Trichlorethylene	CTX300-655	Semiconductor	500	-20 °C to +60 °C	10 % to 95 % RH
Xylene	CTX300-653	Semiconductor	2000	-20 °C to +50 °C	10 % to 95 % RH
	CTX300-660		500	-20 °C to +55 °C	10 % to 95 % RH
Ethanol	CTX300-654	Semiconductor	5000	-20 °C to +60 °C	10 % to 95 % RH
	CTX300-656		500	-20 °C to +50 °C	10 % to 95 % RH
R12	CTX300-500	Semiconductor	10000	-20 °C to +55 °C	10 % to 95 % RH
R22	CTX300-501	Semiconductor	2000	-20 °C to +55 °C	10 % to 95 % RH
R123	CTX300-509	Semiconductor	2000	-20 °C to +55 °C	10 % to 95 % RH
R134a	CTX300-502	Semiconductor	2000	-20 °C to +55 °C	10 % to 95 % RH
R11	CTX300-505	Semiconductor	10000	-20 °C to +55 °C	10 % to 95 % RH
R23	CTX300-506	Semiconductor	10000	-20 °C to +55 °C	10 % to 95 % RH
R143a	CTX300-511	Semiconductor	2000	-20 °C to +55 °C	10 % to 95 % RH
R245fa	CTX300-521	Semiconductor	1000	-20 °C to +55 °C	10 % to 95 % RH
R404a	CTX300-512	Semiconductor	2000	-20 °C to +55 °C	10 % to 95 % RH
R507	CTX300-513	Semiconductor	2000	-20 °C to +55 °C	10 % to 95 % RH
R410a	CTX300-514	Semiconductor	1000	-20 °C to +55 °C	10 % to 95 % RH
R32	CTX300-515	Semiconductor	1000	-20 °C to +55 °C	10 % to 95 % RH
HFO-1234ze	CTX300-525	Semiconductor	1000	-20 °C to +55 °C	10 % to 95 % RH
HFO-1234yf	CTX300-662	Semiconductor	1000	-20 °C to +55 °C	10 % to 95 % RH

Part Number	Accuracy (% at PA full scale)	Life span (in months)	T(50) (seconds)
WC3oO2F	+/- 1.5 %	28	10
WC30O2G	+/- 1.5 %	60	10
WC3AO2G	+/- 1.5 %	60	10
WC3oO2S	+/- 1.5 %	36	< 20
WC3oCOA	+/- 1.5 %	48	15
WC3oCOB	+/- 1.5 %	48	15
WC3oCOC	+/- 1.5 %	48	15
WC3oCOD	+/- 1.5 %	48	< 20
WC3oCOE	+/- 1.5 %	48	< 20
WC3oCO2A	+/- 2 %	60	<20
WC3oCO2B	+/- 2 %	60	<20
WC3oCO2C	+/- 2 %	60	<20
WC3oHSA	+/- 1.5 %	36	15
WC3oHSB	+/- 1.5 %	36	15
WC3oHSC	+/- 1.5 %	36	15
WC3oNOA	+/- 1.5 %	36	15
WC3oNOB	+/- 1.5 %	36	15
WC3oNOC	+/- 1.5 %	36	15
WC3oN2A	+/- 1.5 %	24	20
WC3oN2B	+/- 1.5 %	24	20
WC3oSOA	+/- 1.5 %	36	15
WC3oSOB	+/- 1.5 %	36	15
WC3oSOC	+/- 1.5 %	36	15
WC3oCL2	+/- 1.5 %	24	50
WC3oH2A	+/- 1.5 %	24	50
WC3oH2B	+/- 1.5 %	24	50
WC3oHLA	+/- 1.5 %	18	50
WC3oHLB	+/- 1.5 %	18	50
WC3oHNA	+/- 2 %	24	30
WC3oHNB	+/- 2 %	24	30
WC3oNH3	+/- 3 %	24	<20
WC30NH3F	+/- 3 %	24	<20
WC3oNH1	+/- 3 %	24	<20
WC30NH2	+/- 3 %	24	<20
WC3oOET	+/- 3 %	36	50
WC3oHFA	+/- 3 %	12	50
WC3oO3A	+/- 3 %	18	40
WC3oPH3	+/- 3 %	12	40
WC3oCLO	+/- 2 %	24	50
WC3oCCL	+/- 1.5 %	18	50
CTX300-507		36	40
CTX300-508		36	40
CTX300-652		36	20
CTX300-657			
CTX300-655		36	40
CTX300-653		36	20
CTX300-660		36	20
CTX300-654		36	20
CTX300-656		36	20
CTX300-500		36	30
CTX300-501	+/- 15 % relative to alarm threshold	36	30
CTX300-509		36	30
CTX300-502		36	30
CTX300-505		36	30
CTX300-506		36	30
CTX300-511		36	30
CTX300-521		36	30
CTX300-512	36	30	
CTX300-513	36	30	
CTX300-514	36	20	
CTX300-515	36	20	
CTX300-525	36	30	
CTX300-662	36	30	



Pre-calibrated sensors ease maintenance

Accessories

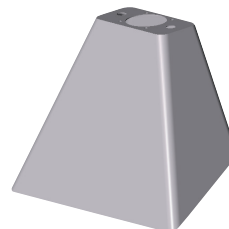

Gas collector

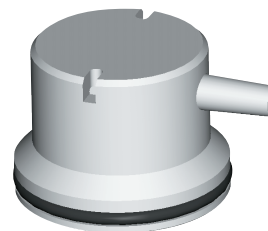

Calibration cup



Remote calibration cup

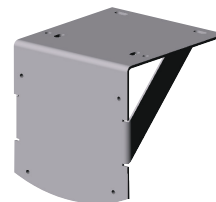

Mounting bracket

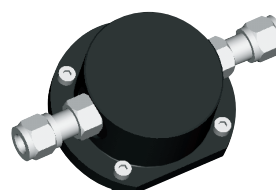

Bypass adapter

Ordering example for CTX 300:

WC3□O2F: - without display Order WC30O2F
- with display Order WC3AO2F

*measures in ppm unless stated otherwise, If you have any questions about other gases or ranges, please consult us at gasandflamedetection@scotssafety.com

Pressure : Atm +/- 10 %, IP 54

3M™ Oldham CTX 300

Transmitter

Clear readability

- Highly sensitive, lighted display allows local reading
- Effective power-up indication by indicator lights
- Indication of maintenance or fault function by LED

High-Level technology

- Pre-calibrated sensor avoiding the need to use unstable gases on site for calibration purposes
- High-performance semiconductor type detector (detection of freon gas, etc.)
- Available in an infrared version for CO₂

Advanced design

- Highly resistant to environmental elements
- Avoids having to use protective covers

Heavy-duty

- Use of polycarbonate and stainless steel mounting hardware
- Resistant to corrosive agents (H₂S, HCl, sea spray,...)
- Durable housing

Specifically adapted options

- Removable filters, interchangeable without opening the housing (which is dust-proof, condensation-proof and water-resistant)
- Splash guard
- Gas collector cone
- Mounting brackets
- Pitot tubes, floats, heating protective device, etc.
- Remote calibration cup

Enclosure	Polycarbonate housing
Function	4-20 mA output analog transmitter
Display	Highly visible backlight LCD display unit (optional, gas dependent)
Indicator lights (3-wire version only)	In operation: green color Failure / maintenance: orange color
Wiring	2 wires shielded cable for CTX300 without display 3 wires shielded cable for CTX300 with display
Cable entry	PG9 cable gland (outer diameter 6 to 11 mm)
Power supply	15 to 32 V DC
Maximum Power Consumption	CTX 300 without display unit: 60 mA CTX 300 with display unit: 110 mA CTX 300 without display semiconductor versions: 100mA
Operating temperature	without display: -40°C to +50°C (-40°F to +122°F), sensor dependent with display: -20°C to +50°C (-4°F to +122°F), sensor dependent
Sealing	IP 54, NEMA 3 & 3R
Weight	520 g (18.2 oz)
Certification	EMC according to EN 50270:06 CSA  US CLASS 812 86, CLASS 4812 06 (SIGNAL APPLIANCES) all versions except CO ₂ versions
Impedance	32 ohms max loop for CTX 300 with display unit and for semiconductor sensor versions 64 ohms max loop for CTX 300 without display unit

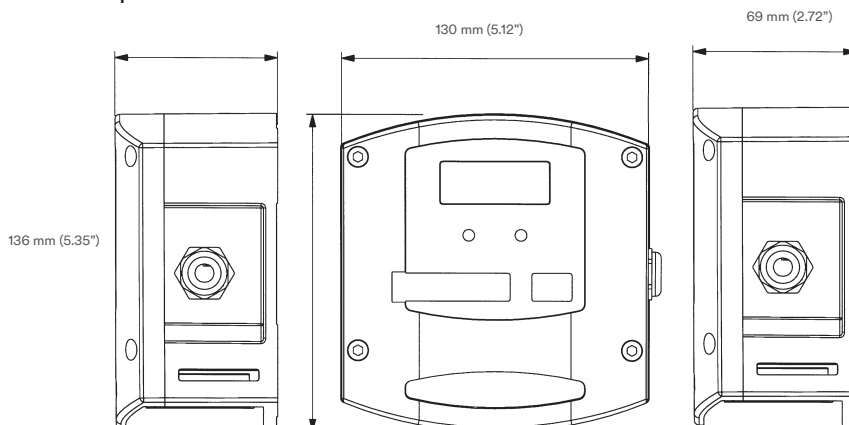



Thank you for reading this data sheet.

For pricing or for further information, please contact us at our UK Office, using the details below.



UK Office

Keison Products,

P.O. Box 2124, Chelmsford, Essex, CM1 3UP, England.

Tel: +44 (0)330 088 0560

Fax: +44 (0)1245 808399

Email: sales@keison.co.uk

Please note - Product designs and specifications are subject to change without notice. The user is responsible for determining the suitability of this product.