

Analogue Gas Detector



Part Number: NP300GB
Revision: M.0
07/2015→

Copyright © 2016 by *Oldham S.A.S.*

April 2016

All rights reserved. No reproduction of all or part of this document, in any form, is permitted without the written consent of *Oldham S.A.S.*

All information provided in this document is accurate to the best of our knowledge.

As a result of continuous research and development, the specifications of this product may be changed without prior notice.

Contents

Chapter 1 General Information	5
User Manual	5
Symbols used.....	5
Safety instructions.....	6
Important information	6
Liability limits	7
Chapter 2 Introduction	9
General Information	9
Composition	10
Chapter 3 Installation and connection	11
Installing the detectors	11
Electrical connections	13
Chapter 4 Powering up and use	19
Powering up	19
4-20 mA analog output.....	20
Chapter 5 Maintenance	21
Calibration	21
Replacing a sensor	29
Disposal.....	29
Chapter 6 Spare parts	31
CTX/COX 300 toxic or oxygen sensors	31
CSC 300 semiconductor sensors.....	34
Chapter 7 Certification	35
Chapter 8 Technical specifications	39

Chapter 9 | Annex43
Indications for calibrating the *CTX 300 SC*.....43
CTX 300 overview44

Chapter 1 | General Information



User Manual

The instructions given in this manual must be read thoroughly before installation and start-up, particularly those concerning the points related to the safety of the end-user. This user manual must be made available to every person involved in the activation, use, maintenance, and repair of the unit. The information, technical data, and diagrams contained in this manual are based on the information that is available at a given time. In case of doubt, contact *Oldham* for additional information.

The aim of this manual is to supply simple and accurate information to the user. *Oldham* cannot be held liable for any misinterpretations in the reading of this manual. In spite of our efforts to produce an error-free manual, it may nonetheless contain some unintentional technical inaccuracies.

In the client's interest, *Oldham* reserves the right to modify the technical characteristics of its equipment to increase their performance without prior notice. The present instructions and their content are the inalienable property of *Oldham*.

Symbols used

Icon	Significance
	This symbol indicates useful additional information.
	This symbol indicates: This equipment must be connected to ground.
	This symbol indicates: Protective earth terminal. A cable of the adequate diameter must be connected to ground and to the terminal having this symbol.



This symbol indicates:
You must refer to the instructions.



This symbol indicates:
Warning! In the present mode of use, failure to adhere to the instructions preceded by this symbol can result in a risk of electric shock and/or death.



European Union (and EEA) only. This symbol indicates that this product must not be discarded with household waste, as per the EEA directive (2002/96/EC) and your own national regulations.

This product must be disposed of at a collection point that is reserved for this purpose, for example, an official site for the collection of electrical and electronic equipment (EEE) in view of their recycling, or a point of exchange for authorized products that is accessible when you acquire a new product of the same type.

Any deviation as regards these recommendations for the disposal of this type of waste can have negative effects on the environment and public health, as these electric and electronic products generally contain substances that can be dangerous. Your full cooperation in the proper disposal of this product promotes a better use of natural resources.

Safety instructions

Labels intended to remind you of the principal precautions of use have been placed on the unit in the form of pictograms. These labels are considered an integral part of the unit. If a label falls off or becomes illegible, please ensure it is replaced. The significance of the labels is detailed below.



The installation and electrical connections must be carried out by qualified personnel according to the instructions of the manufacturer and the standards of the competent authorities.

Failure to adhere to the instructions can have serious consequences on the safety of persons. Please be extremely rigorous as regards electricity and assembly (coupling, network connections).

Important information

The modification of the material and the use of parts of an unspecified origin shall entail the cancellation of any form of warranty.

The use of the unit has been projected for the applications specified in the technical characteristics. Exceeding the indicated values cannot in any case be authorized.

Liability limits

Neither *Oldham* nor any other associated company under any circumstances can be held liable for any damage, including, without limitations, damages for loss or interruption of manufacture, loss of information, defect of the *MX 43* control unit, injuries, loss of time, financial or material loss, or any direct or indirect consequence of loss occurring in the context of the use or impossibility of use of the product, even in the event that *Oldham* has been informed of such damage.

Chapter 2 | Introduction

General Information

CTX300 gas detectors are designed to measure toxic gases or vapors and oxygen. With robust materials, a specifically-adapted design, appropriate accessories, stainless bolts and a polyamide case (IP54), CTX 300 detectors are designed to withstand the roughest conditions.



Figure 1: overview of a CTX 300 with display (left) and without display (right).

Composition

Sensor type	CTX 300		
	Toxic	Oxygen	Semi-conductor
Gases detected	Common toxic gases detected.	Oxygen.	- Combustible gas. - Solvents. - Some Freons.
Detection method	Electrochemical sensors (1).	Electrochemical sensor.	Semiconductor sensor.
Type of sensor pack	Pre-calibrated removable sensor pack (2).	Pre-calibrated removable sensor pack: 0-30% scale or 0-100% volume.	Removable sensor pack, not pre-calibrated.
Options	With display.	With display.	
Certification	None.	None	None

(1) Specific to each gas.

(2) Choice between several scales.

Chapter 3 | Installation and connection

Installing the detectors

Layout

While the measuring sensor is always located on the underside of the detector, several factors determine where the detector should be located:

- If the gas being measured is lighter than the air, place the detector near the ceiling.
- If the gas is heavier than the air (CO₂ and Freons, for example) place the detector close to the floor.
- Near offtake points.
- Generally, in locations where gas may accumulate, taking into consideration both:
 - The effects of temperature;
 - The outside winds direction.

Determining the best sensor location

Factors to consider when determining the best placement for the detector are:

- Potential sources for vapor and gas emissions.
- Characteristics of gases and vapors (density).
- Air circulation:
 - Inside: mechanical or natural ventilation.
 - Outside: wind direction and velocity.
- Effects of temperature.
- Local constraints (air flow, water splash, etc.).

Detectors should always be located in an easily accessible location for maintenance purposes.

Special accessories may be necessary to protect the equipment against any liquid projectiles, dust, direct sunlight or low temperatures in the area.

Mechanical installation

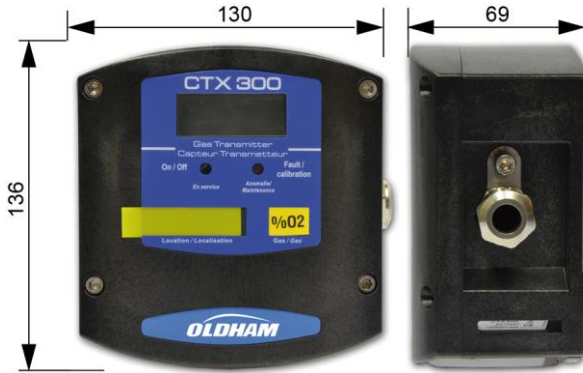

Figure 2: overall dimensions of the CTX 300.

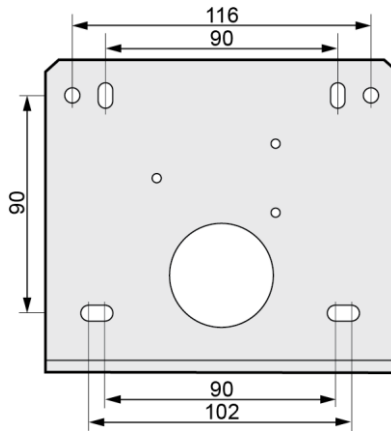

Figure 3: drilling diagram for wall mounting (view of the side flattened onto the ceiling).

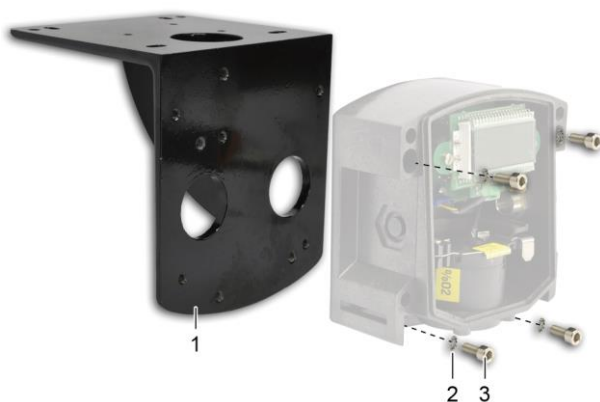

Figure 4: ceiling mounting with a brace. The fixing drawing is identical to this of the wall mount.

Ref.	Qty	Description	Code	Material
1	1	Brace	6132380	Stainless
2	4	Washer A25 ACCD	6905518	Stainless
3	4	Screw CHC LI2	6902218	Stainless

Electrical connections

Wiring specifications

If needed, consult the grounding instructions for *Oldham* instruments and related connection materials in Annex 1.

Connections for the various types of sensors

Wire	CTX 300 (TOX/OX) with display	CTX 300 (TOX/OX) without display	CTX 300 SC without display
Output signal	4-20 mA	4-20 mA	4-20 mA
Active wires	3	2	3
Cable entry	1 x 6-11 mm	1 x 6-11 mm	1 x 6-11 mm

Connection of a 3-wire sensor to an Oldham control unit

Wire	Terminal number
(+) V DC power supply:	3
(-) V DC power supply (masse 0 V):	2
Output signal:	1

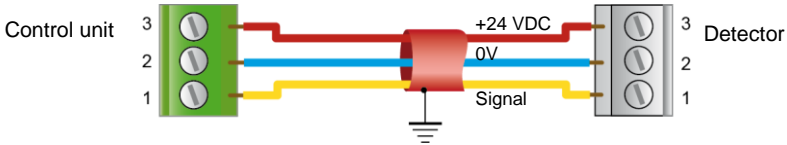

Figure 5: connection of a 3-wire sensor to an Oldham control unit.

Connection of a 2-wire sensor to an Oldham control unit

Wire	Terminal number
(+) V DC power supply:	3
Output signal:	1

Both wires are the 4-20 mA 2-wire loop.

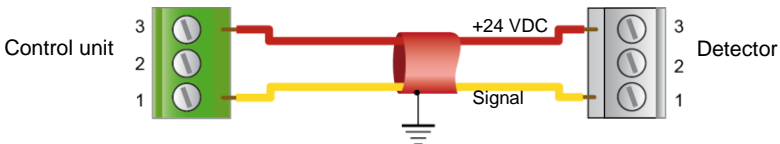

Figure 6: connection of a 2-wire sensor to an Oldham control unit.

Connection of a 3-wire CTX300 sensor to a non-OLDHAM control unit with an internal power supply

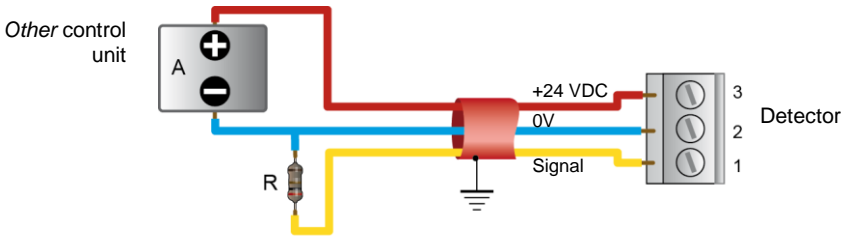

Figure 7: Connection of a 3-wire CTX300 sensor to a non-OLDHAM control unit.

- (R) Maximal load = 200 Ω.
- (A) Power supply $15 \leq V_{cc} \leq 32$.
 $18 \leq V_{cc} \leq 30$ for CO₂ sensor.
 $I_{max} = 130$ mA.

Connection of a 2-wire 4-20mA sensor to a non-Oldham control unit and to an internal power supply

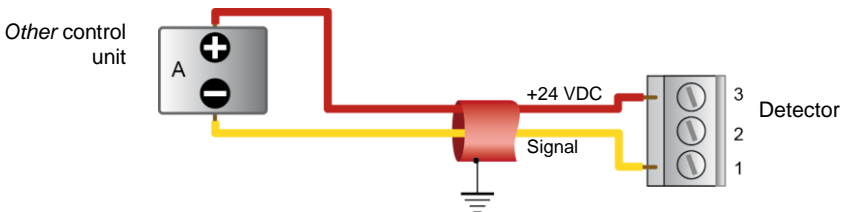

Figure 8: Connection of a 2-wire 4-20mA sensor to a non-Oldham control unit.

- (A) Power supply $15 < V_{CC} < 32V$. $I_{max} = 30$ mA.

Operating mode

CTX300 with display

- Remove the 4 screws (ref. 1).
- Remove the cover (ref. 2).



Figure 9

- Completely remove the screw (ref. 4).
- Unscrew the screw a few turns (ref. 3).



Figure 10

- Turn the display circuit as shown (ref. 5).
- Connect the cable (ref. 6) to the connector. Refer to paragraph *Connections for the various types of sensors* on page 13.
- Return the display circuit to its original position and replace the cover.



Figure 11

CTX 300 without display

- Unscrew the 4 screws (ref. 1).
- Remove the cover (rep. 2).
- Proceed to wire the sensor according to the terminal location.



Figure 12

Chapter 4 | Powering up and use

Powering up

- The sensor turns on when connected to a power supply.
- If the sensor has a display, the green LED will be lit (ref. 2) and a value will appear on the display screen (ref. 1).

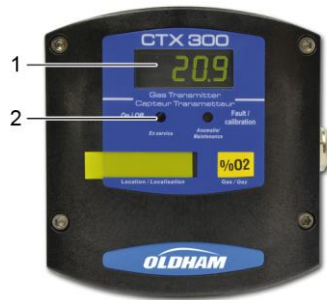

Figure 13

In case of a problem, verify that the maintenance switch (ref. 1), located on the main circuit, is in the *MES* (measure) position.



Figure 14: CTX 300 circuit board.



Figure 15: CTX 300 SC main circuit board.

4-20 mA analog output

For *CTX 300* sensors, the 4-20 mA output current is proportional to the gas level.

The various states of the 4-20 mA output are:

- ≤ 1 mA to indicate a fault.
- = 2 mA in *Calibration* position, except for the CO₂ sensor that does not have a calibration function.
- Between 4 and 20 mA for measurement values.
- ≥ 20 mA if levels exceed measurement range.

Chapter 5 | Maintenance



The adjustment operations in this paragraph are reserved for authorized, trained personnel because they may compromise detection reliability.

Gas detectors are safety devices. OLDHAM recommends the regular testing of fixed gas detection installations. This type of test consists of injecting the calibration gas into the detector at a sufficient concentration to activate the pre-set alarms. It is to be understood that this test is in no way a replacement for a detector calibration.

The frequency of gas tests depends on the industrial application where the detector is in use. Frequent inspections should be made in the months following the commissioning of the installation, and should then become more widely spaced provided that no significant deviation is observed. If a detector should fail to react in contact with the gas, calibration is essential. The frequency of calibrations shall be appropriate according to the results of the tests (humidity, temperature, dust, etc.); however, it must not exceed one year.

The general manager should put safety procedures in place on-site. OLDHAM cannot be held responsible for their enforcement.

Calibration Recommendations

Calibration consists of adjusting the zero of the clean air sensor and adjusting sensitivity with a test gas. Adjustments are made at the sensor level.

Equipment needed to calibrate the detector correctly:

- Flexible plastic tubing (Figure 16, ref. 2).
- Manometer and regulator valve for the compressed gas cylinders (ref. 3).
- 0 to 60 l/h flow meter (if the cylinder is not equipped with one).
- Calibration pipe (ref. 1), which may vary depending on the nature of the gas (see pages 31 and following).
- Test gas cylinder (ref. 4).



Figure 16: sensor calibration assembly.

Zero adjustment should be performed in a gas and vapor free area. If this is not possible, synthetic bottled air can be injected at a rate of 60 l/h.

Use a bottle of test gas to adjust sensor sensitivity (concentration close to the alarm threshold or corresponding to 30% of the measurement range at a minimum). The recommended rate is 60 l/h.

Note: when dealing with dangerous gases, you **MUST** consult a specialized *Oldham* technician or use another sensor pack recently pre-calibrated at a factory.



The detector should be calibrated using the intended flow-rate. The actual concentration of gas may be underestimated if the detector was calibrated with too high of a flow rate.

CTX 300 calibration

1st case: CTX 300 with display (excluding O₂)

- The sensor is operating: the green light (ref. 1) is lit and the display screen shows the measurement level.

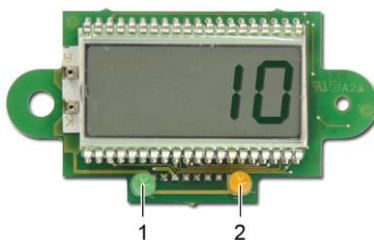

Figure 17

- Flip the maintenance switch (ref. 1) into the **CAL** (calibration) position: the yellow light (Figure 17, ref. 2) will be lit and the sensor will send a 2 mA current to the control unit (*Maintenance mode*).
- Verify that the sensor is located in a clean-air environment. If not, inject synthetic air at a flow rate of 30 l/h.

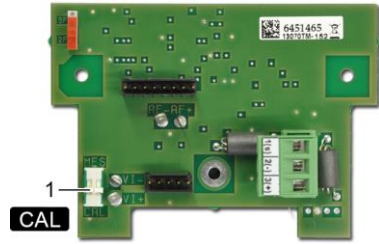

Figure 18

- Wait for the measurement to stabilize (displayed on screen) and adjust the zero by using the **ZERO** potentiometer located on the sensor pack (ref. 2).
- Inject the recommended calibration gas at a flow rate of 30 l/h.
- Wait for the measurement to stabilize.
- Adjust the sensitivity by using the sensitivity potentiometer located on the sensor pack (rep. 1).



Figure 19

- Stop injecting the calibration gas.
- Remove the gas injection pipe, then wait and verify that the signal returns to zero. Repeat procedure if it does not.
- Flip the maintenance switch (rep. 1) into the **MES** (measure) position. The yellow light will turn off (Figure 17, rep. 2).
- Calibration is complete.



Figure 20

2nd case: CTX 300 without display (except for O₂ et SC)

- The sensor is operating.
- Flip the maintenance switch (ref. 1) into the *CAL* (calibration) position: the sensor will send a 2 mA current to the control unit (*Maintenance mode*).
- Verify that the sensor is located in a clean-air environment. Use the calibration kit and follow all recommendations.



Figure 21

- Connect a voltmeter to the AF+ and AF- terminals (caliber mV/DC).

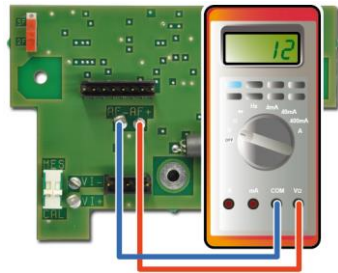

Figure 22

- Wait for the signal to stabilize and adjust the zero by using the ZERO potentiometer located on the sensor pack (Figure 23, ref. 2). The output signal should be 0 mV.
- Now inject the recommended test gas at a flow rate of 30 l/h. Use the calibration kit and follow all recommendations.
- Wait until the signal has stabilized.
- Read the mV value on the voltmeter (Figure 22), with the full scale at 1600 mV. Calculate the value to be read as a function of your test gas.



Figure 23

- Adjust the displayed value using the potentiometer (Figure 23, rep.1).
Example
 - CO sensor.
 - Scale 0-300 ppm.
 - Standard gas concentration: 100 ppm.
 - Reading: 533 mV.
- Shut off the calibration gas injection.
- Withdraw the gas injection pipe.
- Then wait and check that the scale has returned to zero. Otherwise, repeat the entire procedure.
- Switch the maintenance on/off switch to the *MES* (measure) position (ref. 1).

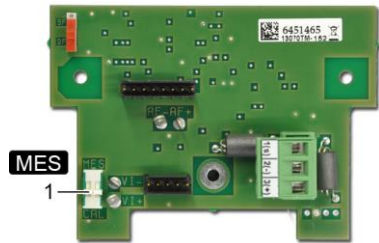

Figure 24

CTX 300 calibration for O₂

This sensor is an Oxygen type.

1st case: CTX 300 O₂ with display

- See paragraph 1st case: CTX 300 with display, on page 22. Proceed only with adjusting sensitivity (rep. 1) by injection of test gas.



Figure 25

2nd case: CTX 300 O₂ without display screen nor LED

- See paragraph 2nd case: CTX 300 without display on page 24. Proceed only with adjusting sensitivity (rep. 1) by injection of test gas.

Signal value mV:

- 1600 mV for full scale, means 30 % O₂.
- 1115 mV for 20.9 % O₂.
- 0 mV for 0% O₂.



Figure 26

Note: the signal sent from the CTX300 (toxic or oxygen) sensor to the control unit can be measured on the main circuit by connecting a millivoltmeter to the pins designed for this purpose (Figure 27).

- 400 mV corresponds to 4 mA.
- 2000 mV corresponds to 20 mA.



Figure 27

CTX 300 calibration (for Semiconductor)

This is a *Semiconductor* type sensor.

- Flip the switch (rep. 1) into the *CAL* position.



Figure 28

- Ensure that the sensor is in clean air, otherwise inject synthetic air into it using the calibration kit and referring to the recommendations below.
Important: to correctly calibrate a sensor equipped with a semiconductor cell, use of a humidifier kit (code 6335919) is MANDATORY.

Using the humidifier kit

- Lift the lid (ref. A) and, using a washbottle, moisten the filter, without saturating it, with distilled water
- Replace the lid and check that all parts are properly assembled and that the assembly is fully airtight.
- Adjust the flow rate to 60 l/h and wait 10 minutes until the humidifier is fully purged.
- Apply the gas introduction pipe (ref. C) to the nose of the sensor and wait at least five minutes for the measurement to stabilize.

Note: the sensor must be powered for at least two hours before any adjustment can be made.

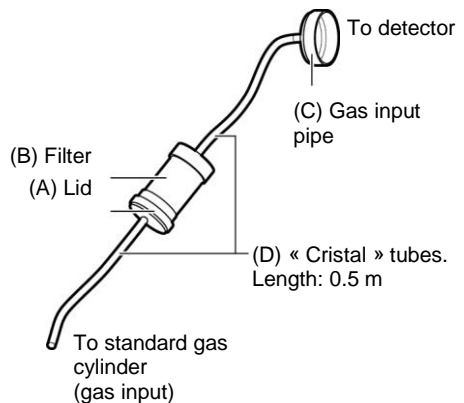

Figure 29: the humidifier kit.

- Connect a voltmeter as indicated and adjust, using potentiometer p5 (ref. 1). The output signal must be equal to 880 mV.
- Next, inject the calibration gas at a flow rate of 30 l/h (refer to paragraph *Indications for calibrating the CTX 300 SC*, on page 43).
- Wait for the signal to stabilize and adjust the signal with the sensitivity potentiometer p6 (ref. 2).

The output signal should be:

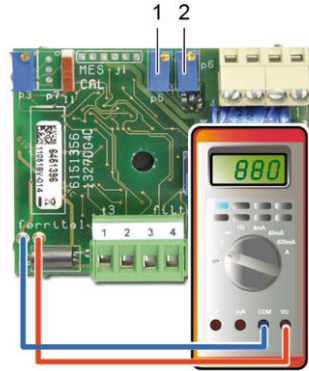

Figure 30

$$U = 880 \text{ mV} + \frac{3520 \text{ mV} \times \text{Cal gas concentration}}{\text{Sensor measurement range}}$$

Example

Sensor measure (% of full range)	Output signal (mV)
0	880
50	2 640
100	4 400

- Stop injecting the calibration gas.
- Verify that the reading returns to zero (880 mV). If it does not, repeat the entire procedure.
- Calibration is complete.
- Flip the switch (ref. 1) into the **MES** (Measure) position.

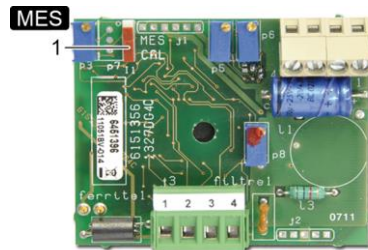

Figure 31

Replacing a sensor

Sensors must be replaced:

- When calibration is no longer possible (no sensitivity);
- During preventative maintenance.

The replacement sensor should be identical to the original sensor (same gas, same range). After a sensor has been replaced, a calibration or test (for pre-calibrated sensors) must be conducted.

Disposal



For the preservation, protection and improvement of environmental quality, and for the protection of human health and the prudent and rational utilization of natural resources, the *CTX 300* must be disposed of separately from electronic equipment and cannot be disposed of with normal household waste. The user therefore has an obligation to separate the *CTX 300* sensor from other waste to ensure that it is recycled safely for the environment. For further details on existing collection sites, contact the local administration or seller of the product.



Chapter 6 | Spare parts



List of spare parts for different detectors.



Replacement parts must imperatively be guaranteed origin *Oldham*. Otherwise, material safety could be jeopardized.

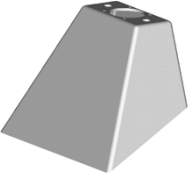
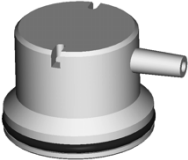



CTX/COX 300 toxic or oxygen sensors

P/N	Description	Picture
6147868	CTX 300 tool kit.	
6322420	Mounting brace and bolts (CTX 300) ceiling mount.	
6323607	Gas collector (s).	
6331141	Gas introduction device for explosible gases and other toxic gases.	

P/N	Description	Picture
6327906	Device for remote gas introduction.	
6335953	Replacement filter. PTFE protector filter.	
<i>Pre-calibrated oxygen sensor pack</i>		
6313C2A	CTX 300 O ₂ , 0-30 % vol sensor pack. (2years)	
6313C5A	CTX 300 O ₂ , 0-30 % vol sensor pack. (5years)	
6313660	CTX 300 O ₂ , 0-100 % vol sensor pack.	
<i>Pre-calibrated toxic sensor pack</i>		
6313627	CTX 300 CO - 100 ppm sensor pack.	
6313628	CTX 300 CO - 300 ppm sensor pack.	
6313629	CTX 300 CO - 1000 ppm sensor pack.	
6313631	CTX 300 CO - 1% vol sensor pack.	
6313632	CTX 300 CO - 10% vol sensor pack.	
6313633	CTX 300 H ₂ S - 30 ppm sensor pack.	
6313634	CTX 300 H ₂ S - 100 ppm sensor pack.	
6313635	CTX 300 H ₂ S - 1000 ppm sensor pack.	
6313636	CTX 300 NO - 100 ppm sensor pack.	
6313637	CTX 300 NO - 300 ppm sensor pack.	
6313638	CTX 300 NO - 1000 ppm sensor pack.	
6313639	CTX 300 NO ₂ - 10 ppm sensor pack.	
6313640	CTX 300 NO ₂ - 30 ppm sensor pack.	
6314001	CTX 300 NO ₂ - 100 ppm sensor pack.	
6313645	CTX 300 ETO - 30 ppm sensor pack.	
6313646	CTX 300 SO ₂ - 10 ppm sensor pack.	
6313647	CTX 300 SO ₂ - 30 ppm sensor pack.	
6313648	CTX 300 SO ₂ - 100 ppm sensor pack.	

P/N	Description	Picture
6313649	CTX 300 Cl ₂ - 10 ppm sensor pack.	
6313650	CTX 300 H ₂ - 30 ppm sensor pack.	
6313651	CTX 300 H ₂ - 100 ppm sensor pack.	
6313652	CTX 300 HCL - 30 ppm sensor pack.	
6313653	CTX 300 HCL - 100 ppm sensor pack.	
6313654	CTX 300 HCN - 10 ppm sensor pack.	
6313655	CTX 300 HCN - 30 ppm sensor pack.	
6313656	CTX 300 NH ₃ - 100 ppm sensor pack.	
6313657	CTX 300 NH ₃ - 1000 ppm sensor pack.	
6313893	CTX 300 NH ₃ - 0-5000 ppm sensor pack.	
6313675	CTX 300 HF - 10 ppm sensor pack.	
6313676	CTX 300 O ₃ - 1 ppm sensor pack.	
6313677	CTX 300 PH ₃ - 1 ppm sensor pack.	
6313919	CTX 300 PH ₃ - 1000 ppm sensor pack.	
6313860	CTX 300 F ₂ - 1 ppm sensor pack.	
6314183	CTX 300 CH ₂ O - 50 ppm sensor pack.	
6 314 185	CTX 300 ASH ₃ - 1 ppm sensor pack.	
6313834	CTX 300 SIH ₄ - 50 ppm sensor pack.	
6313678	CTX 300 ClO ₂ - 3 ppm sensor pack.	
6313833	CTX 300 COCl ₂ - 3 ppm sensor pack.	
<i>Replacement parts</i>		
6323608	Cover without display.	
6323609	Cover with display.	
6815919	CTX 300 without display label.	
6815921	CTX 300 wit display label.	
6451466	Display card.	
6815923	<i>Localization</i> sticker.	
6451465	Motherboard.	

CSC 300 semiconductor sensors

P/N	Description	Picture
6147868	CTX 300 tool kit.	
6322420	Mounting brace and bolts (CTX 300 ceiling mount).	
6323607	Gas collector (stainless).	
6335919	Calibration kit (humidifier filter + pipe).	
6335918	Humidifier filter.	
<i>Replacement sensors</i>		
6313544	Sensor for R134A, R11, R23, R143A, R404A, R507, R410A, R32, R407C, R408A.	
6313545	Sensor for methyl chloride, methylene chloride.	
6313546	Sensor for solvents.	
6313547	Sensor for R22, R12.	
6313464	Sensor for VOC.	
<i>Replacement parts</i>		
6451396	Motherboard.	
6143502	PG9 cable gland.	

Chapter 7 | Certification

The following page reproduces the EC declaration of conformity.



DECLARATION UE DE CONFORMITE
EU Declaration of Conformity



La société **Oldham S.A.S.**, ZI Est 62000 Arras France, atteste que la
Oldham S.A.S. company, ZI Est 62000 Arras France, declares that the

Détecteurs de gaz CTX 300
Gas Detectors CTX 300

sont conformes aux exigences des Directives Européennes suivantes :
comply with the requirements of the following European Directives:

1) Directive Européenne CEM 2014/30/UE du 26/02/14: Compatibilité Electromagnétique
The European Directive EMC 2014/30/UE dated from 26/02/14: Electromagnetic Compatibility

Normes harmonisées appliquées: **EN 50270:06** for type 1 CEM-Appareils de détection de gaz
Harmonised applied Standards *EMC-Apparatus for the detection of gases*

Arras, le 20/04/2016 (April 20th, 2016)

Michel Spellemaecker

Global Director of Product Management



Oldham S.A.S.
Z.I. EST - CS 20417
62027 ARRAS Cedex - FRANCE
Tel. : +33(0)3 21 60 80 80
www.oldhamgas.com

UE_CTX 300_revA



The company Oldham S.A. S., ZI Est, 62000 Arras France, declares that following materials intended for halogenated refrigerant fluid detection,

Gas detectors OLCT 10 & CTX 300

comply with the requirements of the European standard EN 14624 :

Performances of portable leak detectors or atmosphere controllers of halogenated refrigerant fluids.

Technical specifications

Equipment category : Non selective atmosphere controller
 Measuring range : 0-2000 ppm R134a
 Minimum sensitivity threshold : 10 ppm R134a
 Maximum sensitivity threshold : 5000 ppm R134a during 90s without loss of sensitivity
 Minimum alarm threshold : 200 ppm R134a
 Minimum time to detect the lowest concentration : less than 25s after injection of 500 ppm R134a
 Recovery time : less than 160s after injection of 1000 ppm R134a during 8 minutes

Note 1 : For more information about installation, commissioning or safe practices please refer to the user manual of the manufacturer.

Note 2 : Local regulation may apply. For France, please refer to articles R.543-75 to R.543-123 in section 6 of the French Environmental Code (decree #2007-1467 dated from October 12, 2007 and decree #2011-396 dated from 2011, April 13).

Arras, 21/10/2013

Michel Spellenmaeker



Oldham S.A.S.
 ZI EST - BP 417
 62021 ARRAS Cedex - FRANCE
 Tel : +33(0)3 21 60 20 20
 www.oldhamgroup.com



Global Director of Product Management

EN 14624_OLCT 10 _ed_b

Chapter 8 Technical specifications

Enclosure.	Polycarbonate housing.
Function.	Detector-transmitter
Display	Highly visible backlight display unit (optional, gas dependent)
Indicator lights	In operation: green color (on CTX 300 : 3-wire) Failure / maintenance: yellow color
Link	2 wires shielded LiYCY Typ– CTX 300 without display unit 3 wires shielded LiYCY Typ – CTX 300 with display unit (or semiconductor versions)
Cable entry	PG9 cable gland (outer diameter 6 to 11 mm)
Power supply	15 to 32 V DC
Power consumption	CTX 300 without display unit: 27 mA CTX 300 with display unit: 110 mA semiconductor versions: 100mA
Operating temperature	-40°C to + 50°C, 40°F to + 122°F sensor dependent
Sealing	IP 54, NEMA 3 & 3R
Weight	520 g
Dimensions	130 x 136 x 69 (l x h x d) in mm ; (5.12" x 5.35" x 2.72")
Certification	 CCSA – Class 4812 10 – Signal Appliances-Detectors CSAUS – Class 4812 86 - Signal Appliances-Miscellaneous
EMC	Type 1 according to EN 50270:06
Impedance	32 ohms max loop for CTX 300 with display unit and for solid states and CO ₂ sensor versions 128 ohms max loop for CTX 300 without display unit

Gas	Type of sensor	Range (ppm)	Operating temperature	Relative humidity uncondensed	Accuracy (at PA full scale)	Life span (in month)	T(50) (seconds)
O ₂	EC	30.0%	-20°C to +50°C	10% to 95% RH	+/-1.5%	28	10
		30.0%	-40°C to +50°C	10% à 95% RH	+/-1.5%	60	10
		100%	+5°C to +40°C	10% to 95% RH	+/-1.5%	36	<20
CO	EC	100	-20°C to +50°C	10% to 95% RH	+/-1.5%	48	15
		300	-20°C to +50°C	10% to 95% RH	+/-1.5%	48	15
		1000	-20°C to +50°C	10% to 95% RH	+/-1.5%	48	15
		1.00%	-20°C to +50°C	10% to 95% RH	+/-1.5%	48	<20
		10.0%	-20°C to +50°C	10% to 95% RH	+/-1.5%	48	<20
H ₂ S	EC	30.0	-20°C to +50°C	10% to 95% RH	+/-1.5%	36	15
		100	-20°C to +50°C	10% to 95% RH	+/-1.5%	36	15
		1000	-20°C to +50°C	10% to 95% RH	+/-1.5%	36	15
NO	EC	100	-20°C to +50°C	10% to 95% RH	+/-1.5%	36	15
		300	-20°C to +50°C	10% to 95% RH	+/-1.5%	36	15
		1000	-20°C to +50°C	10% to 95% RH	+/-1.5%	36	15
NO ₂	EC	10.0	-20°C to +50°C	10% to 95% RH	+/-1.5%	24	20
		30.0	-20°C to +50°C	10% to 95% RH	+/-1.5%	24	20
SO ₂	EC	10.0	-20°C to +50°C	10% to 95% RH	+/-1.5%	36	15
		30.0	-20°C to +50°C	10% to 95% RH	+/-1.5%	36	15
		100	-20°C to +50°C	10% to 95% RH	+/-1.5%	36	15
Cl ₂	EC	10.0	-20°C to +50°C	10% to 95% RH	+/-1.5%	24	50
H ₂	EC	2000	-20°C to +50°C	10% to 95% RH	+/-1.5%	24	50
		2.0%	-20°C to +50°C	10% to 95% RH	+/-1.5%	24	50
HCl	EC	30.0	-20°C to +50°C	10% to 95% RH	+/-1.5%	18	50
		100	-20°C to +50°C	10% to 95% RH	+/-1.5%	18	50
HCN	EC	10.0	-20°C to +50°C	10% to 95% RH	+/-2%	24	30
		30.0	-20°C to +50°C	10% to 95% RH	+/-2%	24	30
NH ₃	EC	100	-20°C to +40°C	10% to 95% RH	+/-3%	24	<20
		100	-40°C to +40°C	10% to 95% RH	+/-3%	24	<20
		1000	-20°C to +40°C	10% to 95% RH	+/-3%	24	<20
		5000	-20°C to +40°C	10% to 95% RH	+/-3%	24	<20
ETO	EC	30.0	-20°C to +50°C	10% to 95% RH	+/-3%	36	50
HF	EC	10.0	-10°C to +30°C	10% to 95% RH	+/-3%	12	50
O ₃	EC	1.00	-20°C to +50°C	10% to 95% RH	+/-3%	18	40
PH ₃	EC	1.00	-20°C to +50°C	10% to 95% RH	+/-3%	12	40
ASH ₃	EC	1.00	-20°C to +50°C	10% to 95% RH	+/-3%	12	40
ClO ₂	EC	3.00	-20°C to +50°C	10% to 95% RH	+/-2%	24	50
COCl ₂	EC	3.00	-20°C to +40°C	10% to 95% RH	+/-1.5%	18	50
Methylene chloride	SC	500	-20°C to +55°C	10% to 95% RH		36	40

Gas	Type of sensor	Range (ppm)	Operating temperature	Relative humidity uncondensed	Accuracy (at PA full scale)	Life span (in month)	T(50) (seconds)
Methyl chloride	SC	500	-20°C to +60°C	10% to 95% RH	+/-15% relative to alarm threshold	36	40
Toluene	SC	500	-20°C to +50°C	10% to 95% RH		36	20
		2000	-20°C to +50°C	10% to 95% RH		36	20
Trichloroethylene	SC	500	-20°C to +60°C	10% to 95% RH		36	40
Xylene	SC	500	-20°C to +50°C	10% to 95% RH		36	20
		2000	-20°C to +50°C	10% to 95% RH		36	20
Ethanol	SC	500	-20°C to +50°C	10% to 95% RH		36	20
		5000	-20°C to +60°C	10% to 95% RH		36	20
R12	SC	10000	-20°C to +55°C	10% to 95% RH		36	30
R22	SC	2000	-20°C to +55°C	10% to 95% RH		36	30
R123	SC	2000	-20°C to +55°C	10% to 95% RH		36	30
R134a	SC	2000	-20°C to +55°C	10% to 95% RH		36	30
R11	SC	10000	-20°C to +55°C	10% to 95% RH		36	30
R23	SC	10000	-20°C to +55°C	10% to 95% RH		36	30
R143a	SC	2000	-20°C to +55°C	10% to 95% RH		36	30
R404a	SC	2000	-20°C to +55°C	10% to 95% RH		36	30
R507	SC	2000	-20°C to +55°C	10% to 95% RH		36	30
R410a	SC	1000	-20°C to +55°C	10% to 95% RH	36	20	
R32	SC	1000	-20°C to +55°C	10% to 95% RH	36	20	

EC : Electrochemical

SC : Semiconductor

Chapter 9 | Annex

Indications for calibrating the *CTX 300 SC*

This information relates to the *CTX 300* semiconductor.

P/N	Gas types	Measurement range	After sale service standard gas	Test gas
6313545	Methyl Chloride CH ₃ Cl	500 ppm	50 ppm CH ₃ Cl	2000 ppm H ₂ = 190 ppm ± 25ppm
	Methylene chloride CH ₂ Cl ₂	500 ppm	100 ppm CH ₂ Cl ₂	100 ppm CO = 80ppm ± 15 ppm
6313546	Trichloroethylene C ₂ HCl ₃	500 ppm	75 ppm Trichloroethylene	300 ppm CO = 120 ppm ± 35ppm
	Toluene C ₆ H ₅ CH ₃	2 000 ppm	100 ppm Toluene	300 ppm CO = 330ppm ± 50ppm
	Xylene C ₆ H ₄ (CH ₃) ₂	2 000 ppm	100 ppm Xylene	300 ppm CO = 330ppm ± 50ppm
	Ethanol C ₂ H ₅ OH	5 000 ppm	1000 ppm Ethanol	1000ppm H ₂ = 880ppm ± 150ppm
6313547	Freon R12	1 % volume	1000 ppm R12	0.5%CH ₄ =overscale
	Freon R22	2000 ppm	1000 ppm R22	0.5% CH ₄ = 750ppm ± 200ppm
6313544	Freon R134A	2000 ppm	1000 ppm R134A	0.5% CH ₄ = 2000ppm ± 500ppm
	Freon R11	1% volume	1000 ppm R134A = 150 ppm	0.5% CH ₄ =overscale
	Freon R23	1% volume	1000 ppm R22 = 4500ppm	0.5% CH ₄ = 2800ppm ±800ppm

CTX 300 overview

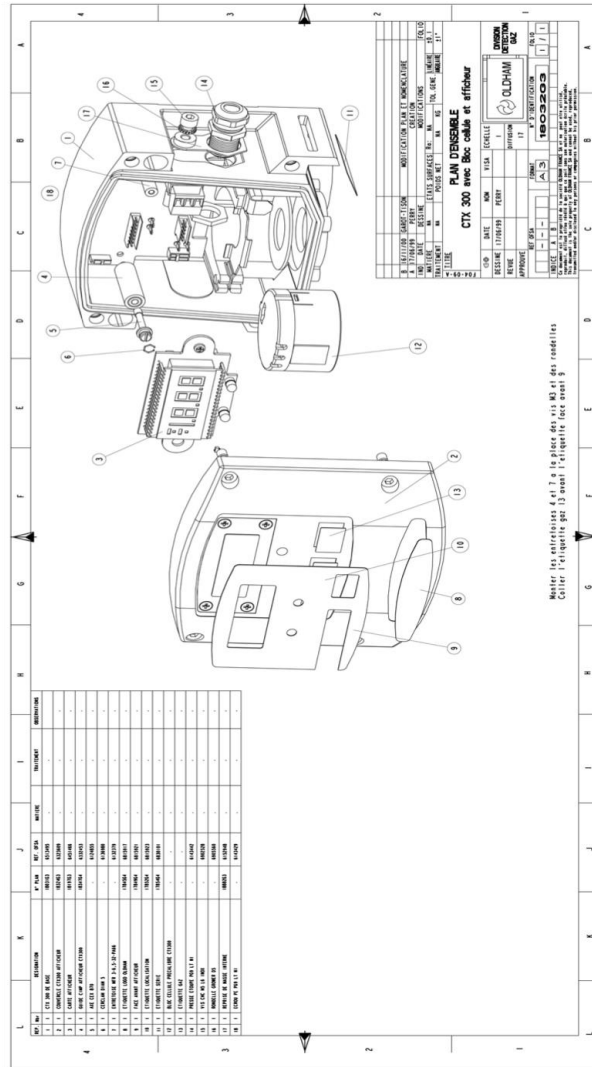

Figure 32: CTX 300 with sensor pack and display – overview.

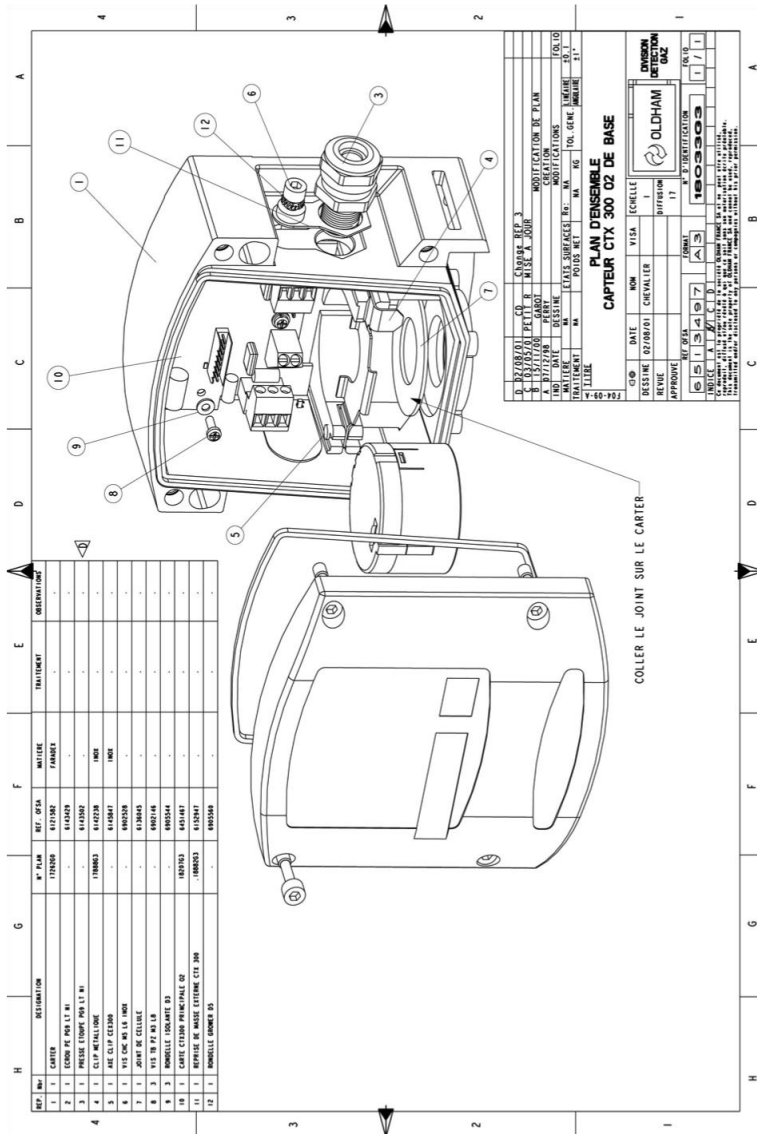

Figure 33: CTX 300 – overview.

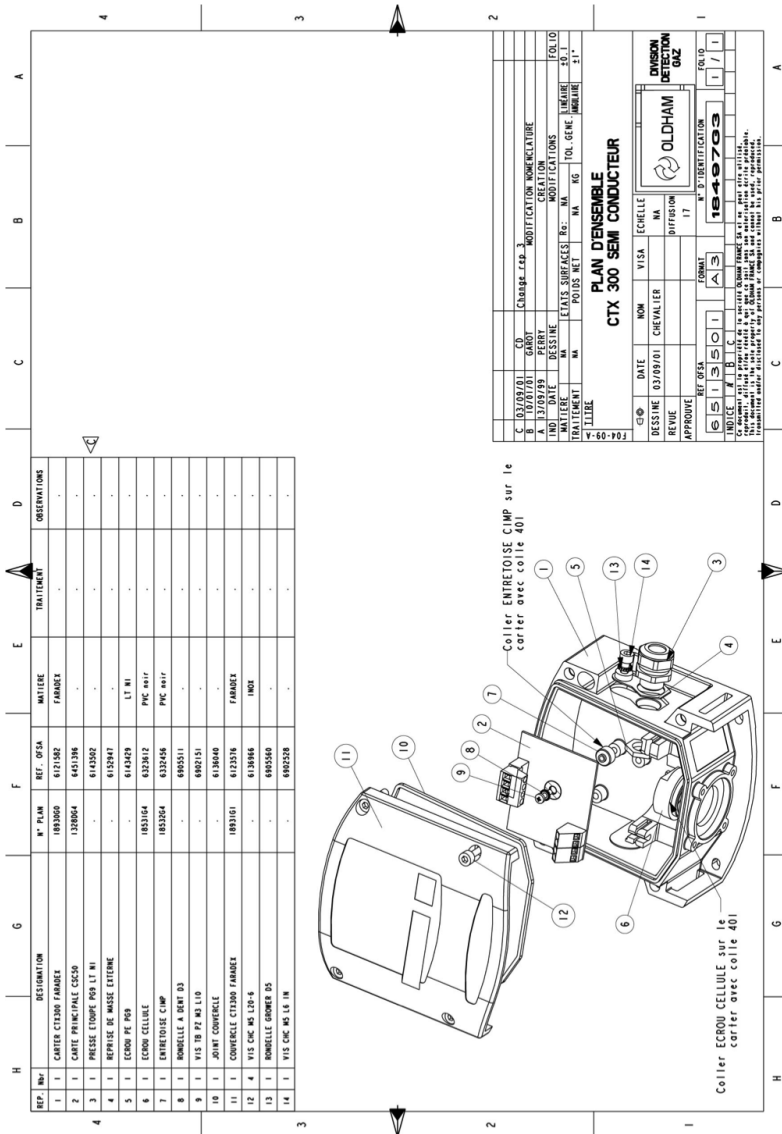

Figure 34: CTX 300 semiconductor– overview.



Thank you for reading this data sheet.

For pricing or for further information, please contact us at our UK Office, using the details below.



UK Office

Keison Products,

P.O. Box 2124, Chelmsford, Essex, CM1 3UP, England.

Tel: +44 (0)330 088 0560

Fax: +44 (0)1245 808399

Email: sales@keison.co.uk

Please note - Product designs and specifications are subject to change without notice. The user is responsible for determining the suitability of this product.