



MULTIFLAME

FV-40 Series Flame Detector



User Guide

087-0056

Rev. F



MultiFlame FV-40 User Guide

FLAME DETECTOR

Legal Notice

© 2018 Scott Safety. SCOTT, the SCOTT SAFETY Logo, Scott Health and Safety, and MultiFlame are registered and/or unregistered marks of Scott Technologies, Inc. or its affiliates.

All rights reserved. No part of this documentation may be reproduced in any form or by any means or used to make any derivative work (such as translation, transformation, or adaptation) without written permission from Scott Safety.

Scott Safety reserves the right to revise this documentation and to make changes in content from time to time without obligation on the part of Scott Safety to provide notification of such revision or change.

Scott Safety provides this documentation without warranty, term, or condition of any kind, either implied or expressed, including, but not limited to, the implied warranties, terms or conditions of merchantability, satisfactory quality, and fitness for a particular purpose. Scott Safety may make improvements or changes in the product(s) described in this documentation at any time.

While every effort has been made to ensure accuracy in this guide, no responsibility can be accepted for errors or omissions. This publication is not intended to form the basis of a contract, and the company reserves the right to amend the design, content, and specifications of the detector without notice.

If you have any questions, please contact: Scott Safety, 4320 Goldmine Road, Monroe, NC 28110, Telephone 800-247-7257, FAX 704-291-8330, E-mail <mailto:scotttechsupport@scottssafety.com>
Web <http://www.scottssafety.com>

Microsoft, Windows, Windows 2000, Windows Me, Windows XP, Windows NT, Windows Vista, Windows 7, Internet Explorer and MS-DOS are either trademarks or registered trademarks of Microsoft Corporation in the United States and other countries. HART is a registered trademark of the HART Communication Foundation. All other products or service names are the property of their respective owners.

The international transport of this device is regulated under United States export regulations and may be regulated by the import regulations of other countries.



Warning: This manual should be read carefully by all individuals who have or will have responsibility for using, maintaining or servicing the product. ***Failure to use this equipment properly may result in serious injury or death.***

The Detector is not field-repairable due to the meticulous alignment and calibration of the sensors and the respective circuits. Do not attempt to modify or repair the internal circuits or change their settings, as this will impair the system's performance and void the Scott Safety product warranty.

Warranty

SCOTT SAFETY Agrees to extend to Purchaser/Distributor a warranty on the SCOTT SAFETY supplied components of the MultiFlame products. SCOTT SAFETY warrants to Purchaser/Distributor that the products are free from defects in materials and workmanship for a period of five (5) years, commencing with the date of shipment from SCOTT SAFETY. SCOTT SAFETY expressly excludes damage incurred in transit from the factory or other damage due to abuse, misuse, improper installation, or lack of maintenance or "Act of God" which are above and beyond its control. SCOTT SAFETY will, upon receipt of any defective product, transportation prepaid, repair or replace it at its sole discretion if found to have been defective when shipped. Said repair or replacement is SCOTT SAFETY'S sole liability under this warranty and SCOTT SAFETY'S liability shall be limited to repair or replacement of the component found defective and shall not include any liability for consequential or other damages. The customer is responsible for all freight charges and taxes due on shipments both ways. This warranty is exclusive of all other warranties express or implied.

Warnings

Ensure you follow the applicable warnings and cautions indicated here. ***Failure to follow the applicable Warnings and Cautions indicated in this User Guide may result in serious injury or death.***
Failure to properly use this equipment may result in serious injury or death.



Warning: This equipment must be operated and serviced by qualified personnel only. Read and understand the guide completely before operating or servicing. Qualified personnel as defined according to local, county, state, federal and individual company standards.



Warning: When in doubt vacate the area immediately. You should vacate the area immediately should the device indicate a warning or alarm condition. You should know and understand your company's safety protocols.



Warning: When the primary device is off line, ensure you have another online device to actively detect flame. The device may be off line due to such activities, like but not limited to, calibration, installation, maintenance, troubleshooting, configuration, wiring and other activities.



Warning: If the device does not function as described herein, remove from service and mark for maintenance. Only use Scott Safety replacement parts.



Warning: Only use the device to monitor the zone for the flame types for which it is set-up to detect.



Warning: Verify the cover, internal PCB's and field wiring are securely in place before applying power and operation.



Warning: Do not expose the device to electrical shock or continuous severe mechanical shock.



Warning: Do not use the device if its enclosure is damaged, cracked, or has missing components.



Warning: Protect the device from dripping liquids and high power sprays.



Warning: Device will not operate without power applied. Thus, it only detects flames while powered.



Warning: Periodically test for correct operation of the system's alarm events by exposing the device to a targeted flames above the high alarm set point.



Warning: Calibration is critical. Calibration should be performed periodically that takes into account device use and environment conditions. Calibrate with known flame simulators and check on a regular schedule.

Related Product Documentation

| Document Name | Purpose | Document ID |
|--------------------------|---|--------------------|
| WinHost | Software to change the required functions and for maintenance of the unit. | 0087-0058 |
| HART Communicator | Device to change the required functions and for maintenance of the unit, using HART protocol. | 087-0057 |

If you have any questions regarding the product of this manual, contact Scott Safety at 1-800-247-7257, or refer to Technical Support section for other contact information.

Release History

| Rev | Revision History |
|-----|---|
| A | Initial Release |
| B | Not released. |
| C | Updated ATEX approvals. Removed references to the Mini Laptop Kit and its I.S. Handheld Unit manual. |
| D | Update to ATEX and IECEX certificate numbers. |
| E | Technical/Specification updates. Product brand changed to 'MultiFlame'. |
| F | Edited text in Section D.1.4; added 3M logo, and removed all references to Tyco; updated service center contact info. |

About this Guide

This guide describes the MultiFlame FV-40 Series Flame Detector and its features and provides instructions on how to install, operate and maintain the detector.

This guide includes the following chapters and appendixes:

- **Chapter 1, Introduction**, provides a general overview of the product, principles of operation, and performance considerations.
- **Chapter 2, Installing the Detector**, describes how to install the detector including preparations before installation, wiring and mode settings.
- **Chapter 3, Operating the Detector**, describes how to power-up and test the detector. The chapter also lists safety precautions you should take when operating the detector.
- **Chapter 4, Maintenance and troubleshooting**, describes basic maintenance procedures, and troubleshooting and support procedures.
- **Appendix A, Technical Specifications**: Lists the detectors technical and other specifications.
- **Appendix B, Wiring Instructions**, lists the wiring instructions for connecting the detector and also provides examples of typical wiring configurations.
- **Appendix C, RS-485 Communication Network**, provides an overview of the RS-485 communications network.
- **Appendix D, Accessories**, describes the accessories available for the detector.
- **Appendix E, SIL-2 Features**, describes the special conditions to comply with the requirements of EN 61508 for SIL 2 according to TUV.
- **Appendix F, Online FV-40 Configurator Part Code**, describes the part codes to place an order for the FV-40.

Abbreviations and Acronyms

| Abbreviation | Meaning |
|--------------|---|
| ATEX | Atmosphere Explosives |
| AWG | American Wire Gauge |
| BIT | Built In Test |
| EMC | Electromagnetic Compatibility |
| EOL | End of Line |
| FOV | Field of View |
| HART | Highway Addressable Remote Transducer-communication protocol |
| IAD | Immune at Any Distance |
| IECEX | International Electrotechnical Commission Explosion |
| IPA | Isopropyl Alcohol |
| IR | Infrared |
| JP5 | Jet Fuel |
| Latching | Refers to relays remaining in the ON state even after the ON condition has been removed |
| LED | Light Emitting Diode |
| LPG | Liquefied Petroleum Gas |
| mA | MilliAmps (0.001 amps) |
| MODBUS | Master-slave messaging structure |
| N.C. | Normally Closed |
| N.O. | Normally Open |
| N/A | Not Applicable |
| NFPA | National Fire Protection Association |
| NPT | National Pipe Thread |
| SIL | Safety Integrity Level |
| UNC | Unified Coarse Thread |
| μ | Micron is a measure of wavelength |
| VAC | Volts Alternating Current |

Table of Contents

| | |
|--|-----------|
| Legal Notice | iii |
| Warranty..... | iv |
| Warnings | iv |
| Related Product Documentation..... | vi |
| Release History | vii |
| About this Guide | viii |
| Abbreviations and Acronyms | ix |
| 1 Introduction | 6 |
| 1.1 Overview | 6 |
| 1.2 Model and Types..... | 7 |
| 1.3 Features and Benefits | 10 |
| 1.4 Principles of Operation..... | 11 |
| 1.4.1 Detection Principles..... | 11 |
| 1.4.2 Heated Optics..... | 13 |
| 1.4.3 HART Protocol | 14 |
| 1.4.4 RS-485 Modbus | 14 |
| 1.4.5 Product Certification | 14 |
| 1.5 Performance Considerations | 16 |
| 1.5.1 Detection Sensitivity..... | 16 |
| 1.5.2 Cone of Vision | 17 |
| 1.5.3 False Alarms Prevention..... | 18 |
| 1.5.4 Visual Indicators | 19 |
| 1.5.5 Output Signals..... | 20 |
| 1.5.6 Detector Status | 21 |
| 1.5.7 Auxiliary Relay as End-of-Line Resistor..... | 22 |
| 1.6 Internal Detector Tests | 22 |
| 1.6.1 Built-In-Test (BIT) | 23 |
| 2 Installing the Detector..... | 26 |
| 2.1 General Guidelines | 26 |
| 2.2 Unpacking the Product..... | 27 |
| 2.2.1 Checking the Product Type | 28 |

- 2.3 Required Tools..... 28
- 2.4 General Instructions 29
 - 2.4.1 Special Instructions for Safe Use 29
- 2.5 Installation Cables..... 31
 - 2.5.1 Conduit Installation 31
- 2.6 Installing the Tilt Mount 32
 - 2.6.1 Tilt Mount Assembly 32
- 2.7 Connecting the Detector 34
 - 2.7.1 Verifying the Detector Wiring 35
- 2.8 Configuring your Detector 36
 - 2.8.1 Sensitivity..... 37
 - 2.8.2 Alarm Delay 37
 - 2.8.3 Address Set-up..... 38
 - 2.8.4 Function Set-up 38
 - 2.8.5 Heated Optics..... 38
- 3 Operating the Detector 40**
 - 3.1 Powering Up..... 40
 - 3.2 Safety Precautions 41
 - 3.2.1 Default Functions Settings 41
 - 3.3 Testing Procedures..... 42
 - 3.3.1 Automatic BIT Test..... 42
 - 3.3.2 Manual BIT Test..... 42
 - 3.3.3 Testing with Flame Simulators 42
- 4 Maintenance and Troubleshooting 44**
 - 4.1 Maintenance..... 44
 - 4.1.1 General Procedures 44
 - 4.1.2 Periodic Procedures 45
 - 4.1.3 Keeping Maintenance Records..... 45

- 4.2 Troubleshooting 45
- Appendices..... 47**
- A Specifications 48**
- A.1 Technical Specifications 48
- A.2 Electrical Specifications 51
- A.3 Outputs 52
- A.4 Mechanical Specifications 54
- A.5 Environmental Specifications 54
- B Wiring Instructions..... 56**
- B.1 General Instructions for Electrical Wiring 56
- B.2 Typical Wiring Configurations..... 58
- C RS-485 Communication Network 62**
- C.1 RS-485 Overview 62
- D Accessories..... 63**
- D.1 Long Range Flame Simulators 63
- D.1.1 Unpacking..... 64
- D.1.2 Operating Instructions 64
- D.1.3 Range 64
- D.1.4 Charging the Battery 65
- D.1.5 Technical Specifications 67
- D.2 Tilt Mount 68
- D.3 Duct Mount 69
- D.4 Weather Protection..... 70
- D.5 Laser Detection Coverage Pointer 71
- D.6 Air Shield..... 72
- E SIL-2 Features..... 73**
- E.1 FV-40 Series Flame Detector 73
- E.1.1 Safety Relevant Parameters..... 73
- E.1.2 Guidelines for Configuring, Installing, Operating and Service 73
- F F Online FV-40 Configurator Part Code 76**
- F.1 Technical Support 79

List of Figures

| | |
|---|----|
| Figure 1: Indication LED..... | 19 |
| Figure 2: Detector with Tilt Mount | 32 |
| Figure 3: Tilt Mount Assembly | 32 |
| Figure 4: Tilt Mount Assembly (dimensions in mm and inches) | 33 |
| Figure 5: Detector with Cover Removed | 35 |
| Figure 6: Wiring Terminals | 58 |
| Figure 7: Typical Wiring for 4 Wire Controllers (Using Option 1 or 2 Wiring)..... | 59 |
| Figure 8: 0-20mA Wiring Option 1 (Sink 4-Wire) - Default | 60 |
| Figure 9: 0-20mA Wiring Option 1 (Converted to Source 3-Wire) | 60 |
| Figure 10: 0-20mA Wiring Option 1 (Non-isolated Sink 3-Wire) | 61 |
| Figure 11: 0-20mA Wiring Option 2 and 3 (Source 3-Wire available with the HART Protocol)..... | 61 |
| Figure 12: RS-485 Networking | 62 |
| Figure 13: Flame Simulator 380114-1 | 63 |
| Figure 14: Flame Simulator Battery Replacement..... | 65 |
| Figure 15: Tilt Mount | 68 |
| Figure 16: Duct Mount | 69 |
| Figure 17: Weather Protection | 70 |
| Figure 18: Laser Detection Coverage Pointer..... | 71 |
| Figure 19: Air Shield..... | 72 |

List of Tables

| | |
|---|----|
| Table 1: Base Part Number / Sensor Type | 7 |
| Table 2: Part Dash Number / Configuration Code | 8 |
| Table 3: Configuration Code Key | 9 |
| Table 4: Detector Sensitivity Range Levels..... | 16 |
| Table 5: Fuel Sensitivity Ranges..... | 17 |
| Table 6: False Alarms Prevention..... | 18 |
| Table 7: Welding Immunity Distance..... | 19 |
| Table 8: LED Indications | 19 |
| Table 9: Available Output Types | 20 |
| Table 10: Detector Status | 21 |
| Table 11: Output Signals versus Detector State..... | 21 |
| Table 12: Result of a Successful BIT | 24 |
| Table 13: Results of an Unsuccessful BIT..... | 24 |
| Table 14: Results of a Successful Manual BIT | 25 |
| Table 15: Results of an Unsuccessful Manual BIT | 25 |
| Table 16: Tools..... | 28 |
| Table 17: Flame path dimensions | 29 |
| Table 18: FV-40 Series Wiring Options | 35 |
| Table 19: Sensitivity Settings | 37 |
| Table 20: Functions..... | 38 |
| Table 21: Default Function Values | 41 |
| Table 22: Results of Successful Fire Simulator Test | 43 |
| Table 23: Troubleshooting Table..... | 46 |
| Table 24: Electrical Specifications..... | 51 |
| Table 25: Contact Ratings | 52 |
| Table 26: 20 mA Current Output | 53 |
| Table 27: Electromagnetic Compatibility (EMC) | 55 |
| Table 28: Maximum DC resistance at 68°F (20°C) for copper wire..... | 56 |
| Table 29: Wiring length in feet (meter) | 57 |
| Table 30: Wiring Connections | 59 |
| Table 31: Sensitivity Ranges..... | 64 |
| Table 32: EMI Compatibility..... | 67 |
| Table 33: Part Number Configuration (Online Ordering) | 76 |
| Table 34: Configurable Options (Online Ordering) | 77 |

1 Introduction

1.1 Overview

Depending on the model selected, the FV-40 Series can provide a combination of UV and IR sensors, where the IR sensor operates at a wavelength of 2.5-3.0 μm , and can detect hydrocarbon-based fuel and gas fires, hydroxyl and hydrogen fires, as well as metal and inorganic fires with ultrafast ability to detect fire or explosion in less than 20 msec. Other models have an IR sensor works at a wavelength of 4.5 μm and are only suitable for hydrocarbon-based fires.

Note Models FV-UV and FV-UB: These UV Flame detectors should not be exposed to a UV radiation source, for example; welding, sparks and an electronic arc, as it will result in a false alarm.

All FV-40 Series detectors include a heated optical window for improved performance in icing, snow and condensation conditions.

Detection performance can be easily adapted to all environments, applications and requirements, by changing the detector's configuration parameters. Adjusting these parameters, as well and performing other maintenance and monitoring tasks, is possible by means of RS-485 based Modbus communication or HART communication (in models with 0-20mA output).

The detector enclosure is ATEX certified Exd flameproof with an integral, segregated, rear, Exe terminal compartment (avoiding exposure of the sensors and electronics to surrounding environment). Hence the combined approval.

Ex II 2G DEx db eb op is IIC T4 GbEx tb op is IIIC T96°C Db
(-55°C \leq Ta \leq +75°C)

or

Ex II 2G DEx db eb op is IIC T4 GbEx tb op is IIIC T106°C Db
(-55°C \leq Ta \leq +85°C)

The MultiFlame FV-40 detectors are designed to operate as a stand-alone unit directly connected to an alarm system or an automatic fire extinguishing system. The detector can also be a part of a more complex system, where many detectors and other devices are integrated through a common control unit.



Warning: The MultiFlame units are only a detector of open flames. They do not provide an audible or visible alarm. If audible, visible, or other warning is required, failure to connect the MultiFlame unit to the required alarm could result in serious injury or death.

1.2 Model and Types

Failure to choose and use the proper model and detector sensor type for a given site and location may result in serious injury or death.

The FV-40 Series flame detectors are provided in various configurations depending on:

- Type of Sensor
- Wiring options
- Temperature ranges
- Type of cable entries
- Housing type
- Required regulatory approval

Using the part number found on the regulatory label of the unit, here is the definition of the base features for your unit:

Table 1: Base Part Number / Sensor Type

| Base Part Number | Detector Sensor Type |
|-------------------------|-------------------------------------|
| 093-0554 | Single IR |
| 093-0555 | Multi IR |
| 093-0556 | Triple IR |
| 093-0557 | UV |
| 093-0558 | UV-B (with BIT) |
| 093-0559 | UV/IR 2.5um wavelength |
| 093-0560 | UV/IR B 2.5um wavelength (with BIT) |
| 093-0561 | UV/IR 4um wavelength |
| 093-0562 | UV/IR B 4um wavelength (with BIT) |
| 093-0611 | Ultra Fast UV/IR |

Following the base part number is a two digit "Dash" number -01 through -40 which identifies specific features as defined below:

Table 2: Part Dash Number / Configuration Code

| Dash number | Config Code | Dash number | Config Code | Dash number | Config Code |
|-------------|-------------|-------------|-------------|-------------|-------------|
| -01 | 1 F A | -21 | 3 D S | -41 | 1 E S |
| -02 | 1 F S | -22 | 3 A A | -42 | 1 B S |
| -03 | 1 A S | -23 | 3 C A | -43 | 1 E A |
| -04 | 1 C S | -24 | 3 D A | -44 | 1 B A |
| -05 | 1 D S | -25 | 4 F A | -45 | 2 E S |
| -06 | 1 A A | -26 | 4 F S | -46 | 2 B S |
| -07 | 1 C A | -27 | 4 A S | -47 | 2 E A |
| -08 | 1 D A | -28 | 4 C S | -48 | 2 B A |
| -09 | 2 F A | -29 | 4 D S | -49 | 3 E S |
| -10 | 2 F S | -30 | 4 A A | -50 | 3 B S |
| -11 | 2 A S | -31 | 4 C A | -51 | 3 E A |
| -12 | 2 C S | -32 | 4 D A | -52 | 3 B A |
| -13 | 2 D S | -33 | 5 F A | -53 | 4 E S |
| -14 | 2 A A | -34 | 5 F S | -54 | 4 B S |
| -15 | 2 C A | -35 | 5 A S | -55 | 4 E A |
| -16 | 2 D A | -36 | 5 C S | -56 | 4 B A |
| -17 | 3 F A | -37 | 5 D S | -57 | 5 E S |
| -18 | 3 F S | -38 | 5 A A | -58 | 5 B S |
| -19 | 3 A S | -39 | 5 C A | -59 | 5 E A |
| -20 | 3 C S | -40 | 5 D A | -60 | 5 B A |

Use the 3 character configuration code from above to determine the specific features of your product based on the description in the Table 3 below.

Table 3: Configuration Code Key

| Code 1 | Wiring | Code 2 | Approval / Thread type / Max Temp | Code 3 | Housing |
|--------|--|--------|--|--------|-----------------|
| 1 | RS485, 4-20mA as Sink, Fault relay NC, no Accessory relay, Alarm relay NO, HART | F | Factory Mutual, 3/4 English Thread and 75C | S | Stainless Steel |
| 2 | RS485, 4-20mA as Source, Fault relay NC, no Accessory relay, Alarm relay NO/NC, HART | A | ATEX, M25 Thread, 75C | A | Aluminum |
| 3 | RS485, 4-20mA as Source, Fault relay NO, no Accessory relay, Alarm Relay NO/NC, HART | C | ATEX, 3/4 English Thread, 75C | | |
| 4 | RS485, no 4-20mA, Fault relay NC, Accessory relay NO, Alarm relay NO | D | Factory Mutual, M25 Metric Thread and 75C | | |
| 5 | RS485, no 4-20mA, Fault relay NO, Accessory relay NO, Alarm relay NO | | | | |
| | | | | | |

Other user selectable options for the MultiFlame Detector come from the factory set as follows, unless otherwise specified by the customer when ordering:

- Alarm Delay: 3 seconds
- Optics Heating: Automatic on temperature change
- Alarm Bit: Enable automatic Bit
- Accessory Relay: None
- Sensitivity: 30 meters (100 feet)

The options can be adjusted by the user in the field using the *HART Protocol 087-0057*, WinHost for FV-40 Flame Detectors *087-0058* or *087-0055*.

When ordering the FV-40 online, the product configuration detail is included in the product part number (and on the sales order confirmation) and takes the form: F4-XX-X-X-X-XX-X-X-X-X, where XX-X-X-X-XX-X-X-X-X defines the model according to the Tables 30 and 31. However, the actual FV-40 detectors will be marked with the 093-XXXX-XX part numbering on the regulatory tag, as described in Tables 1, 2 and 3.

1.3 Features and Benefits

- **F4-2V, F4-2B, F4-4V, and F4-4B UV/IR Dual Sensor**
 - UV/IR Dual Sensor
 - High Speed Response: 200msec. response to flash fire
- **F4-I3 Triple IR Sensor**
 - Advanced Digital Processing of the Dynamic Characteristics of Fire: Flickering, threshold correlation and ratio.
 - Multi IR Channels: Between 2-5 microns.
 - Field Programmable Sensitivity: Four ranges to avoid zone crossover.
- **F4-MM Multi IR Sensor**
 - Detects Hydrocarbons and Hydrogen Flames.
 - Detection Range: Up to 215 ft. (65m) for a 1 ft² (0.1m²) n-heptane fire.
 - Advanced Digital Processing of the Dynamic Characteristics of Fire: Flickering, threshold correlation and ratio.
- **F4-UV, F4-UB UV Sensor**
 - UV Sensor design
 - High Speed Response: 200msec. response to flash fire
- **F4-UF UV/IR Ultra Fast Dual Sensor**
 - High Speed Response: 20msec. response to flash fire
- **General Information for all Sensor Models**

Ultra High Immunity to False Alarms: See Table 6: False Alarms Prevention

- See Table 6 on page 18.
- Built In Test (BIT): Automatic (see *Built-In-Test (BIT)*).
- Heated Window: Prevents effects of icing, snow, condensation.
- Electrical Interface:
 - Dry contact relays
 - Communication network RS-485
 - 0-20mA output
- HART Protocol: Communication protocol (see *HART Protocol*).
- Exde: Integral junction box for easy wiring.
- SIL-2: TÜV approval (pending on some models).
- Hazardous Area Certification: ATEX, IECEx, FM.
- Functionality Approval: (next page)

- FM approved per FM3260
- EN54-10 pending by VdS

1.4 Principles of Operation

This section describes the FV-40 Series principles of operation and includes:

- Detection Principles
- Heated Optics
- HART Protocol
- RS-485 Modbus
- Product Certification

1.4.1 Detection Principles

The FV-40 Series Flame Detectors are electronic devices designed to sense the occurrence of fire and flames and subsequently activate an alarm or an extinguishing system directly or through a control circuit. Please refer to the appropriate section below for the model of interest.

F4-I3 Triple IR Flame Detector

The detector's principle of operation is based on patented IR3 technology. This technology identifies the unique spectral signature that hot CO₂ has in the infrared (IR), namely a peak of the intensity at wavelengths 4.2 to 4.7 μ .

The original IR3 technique (such as implemented in the MultiFlame F4-I3 flame detector) utilizes three infrared sensors, each sensitive to its own wavelength range. The first sensor is sensitive to wavelengths within the emission peak of hot CO₂. The other two sensors are sensitive to wavelengths above and below this peak. In the event of fire, the signal measured in the first sensor is significantly higher than those measured in the other two sensors. In order to issue a fire alarm, the detector requires that this occurs, as well as other conditions (for example, radiation is flickering in frequencies typical of flames). If exposed to non-fire radiation sources, the specific conditions required does not occur, and the detector does not react.

The MultiFlame F4-I3 further includes an additional IR sensor, sensitive to a different band within the emission peak of hot CO₂. The signal of this sensor is compared to those of the other three. This increases sensitivity for some types of flames. (For example, gas flames).

F4-2V, F4-2B, F4-4V, and F4-4B UV/IR Dual Sensor

The UV/IR Radiation Flame Detector is a dual spectrum optical detector sensitive to two separate ranges of the radiation spectrum, both of which are present in fires. The detector monitors the protected volume, by measuring the radiation intensity in it, within two frequency ranges of the electromagnetic spectrum, namely the Ultra-Violet (UV) and the Infra-Red (IR).

The detector integrates two dependent channels in which appropriate detection pulses are registered and further analyzed for frequency, intensity and duration.

F4-MM Multi IR Sensor

The MultiFlame Multi IR detector is designed to detect hydrocarbon flames that produce CO₂ in their combustion process and non-hydrocarbon flames that produce mainly water vapor (H₂O) from inorganic fuels, for example, hydrogen, ammonia, hydrofluoric acid, hydrochloric acid and so on.

The detector's principle of operation is based on the patented spectral analysis technology that identifies the IR spectral signature of fire products, namely the hot CO₂ spectral emission band at 4.2-4.7 microns and the hot water (H₂O) spectral emission band at 2.7-3.0 microns. Additional spectral bands (above and below these bands) are analyzed for background interferences.

The spectral analysis incorporates several detection algorithms, according to several types of fire events, taking into account simultaneous detection of both CO₂ and H₂O peaks, or only one of them, as well as flickering analysis at frequencies typical to these flames. Only when all the parameters of the spectral analysis and the flickering analysis meet the predetermined values, is a fire condition identified and the fire alarm is issued.

When exposed to non-fire radiation sources, these parameters do not identify a fire condition and the detector does not react.

F4-UF UV/IR Flame Detector

The UV/IR Radiation Flame Detector is a dual spectrum optical detector sensitive to two separate ranges of the radiation spectrum, both of which are present in fires. The detector monitors the protected volume, by measuring the radiation intensity in it, within two frequency ranges of the electromagnetic spectrum, namely the Ultra-Violet (UV) and the Infra-Red (IR).

The detector integrates two dependent channels in which appropriate detection pulses are registered and further analyzed for frequency, intensity and duration.

- **Sensing Elements**

The IR sensor in FV-40 Models is sensitive to radiation over the range of 2.5-3.0 μm where the H_2 emission has a unique spectral peak that enables detection of hydrocarbon fires, gas fires, hydroxyl and hydrogen fires as well as metal and inorganic fires. Or alternatively, the IR sensor in models sensitive over a range of 4.4-4.6 μm spectral band where the CO_2 has a unique spectral peak that enables it to detect the combustion product of any organic substance, depending on model selected.

The UV sensor is sensitive to radiation over the range of 0.185-0.260 μm . The UV Channel incorporates a special logic circuit that eliminates false alarms caused by solar radiation and other non-fire UV source. Furthermore, the UV channel's sensitivity is stabilized over the working temperature range.

- **Detection Levels**

Simultaneous detection of radiation in both the UV and the IR channels having an intensity that exceeds the detector's preset Warning level results in a Warning signal.

Simultaneous detection of radiation in both the UV and the IR channels having an intensity that exceeds the detector's preset Alarm level results in an Alarm signal.

Simultaneous detection of radiation in both the UV and the IR channels having an intensity that exceeds the detector's preset Flash-Fire Detection level results in an immediate Alarm signal.

Since the preset dual range and level of radiation, as well as the flickering pattern, are characteristics of real fire, all other radiation sources apart from actual fire are not detected, thus avoiding false alarms.

1.4.2 Heated Optics

The MultiFlame FV-40 Flame Detectors use heated optics. The heater increases the temperature of the optical surface by 5-8°F (\sim 3-5°C) above the ambient temperature to improve performance in icing, condensation and snow conditions.

The heated optics can be set to one of the following:

- Not operated
- On continuously
- Automatic, per temperature change (default): you can define the start temperature below which the window is heated. (The default is 41°F (5°C).) This temperature can be defined between 32°F (0°C) to 122°F (50°C). The heating stops when the temperature is 27°F (15°C) above the start temperature.

For more information, see *Configuring your Detector*.

1.4.3 HART Protocol

The FV-40 Series Flame Detectors use the HART protocol.

HART Communication is a bi-directional industrial field communication protocol used to communicate between intelligent field instruments and host systems. HART is the global standard for smart process instrumentation and the majority of smart field devices installed in plants worldwide are HART-enabled. HART is available in wiring options 2 and 3, see Table 18.

HART technology is easy to use and very reliable.

Through the HART connection, you are able to perform:

- Detector set-up
- Detector troubleshooting
- Detector health and status

For more details, refer to the *HART Manual 087-0057*.

1.4.4 RS-485 Modbus

For more advanced communications, the FV-40 Series detectors have an RS-485 Modbus-compatible output that provides data communication from a network (up to 247 detectors) to a host computer or universal controller for central monitoring. This feature allows for reduced installation costs, easy maintenance and local or remote diagnostic tools.



1.4.5 Product Certification

The FV-40 Series Flame Detectors have the following certifications:

- ATEX, IECEx
- FM
- SIL-2 Approved (TÜV)
- EN54-10
- INMETRO

1.4.5.1 ATEX, IECEx

The FV-40 Series Flame Detectors are certified to:

- | | | |
|--|-----------|--|
| <ul style="list-style-type: none"> • ATEX per SIRA 13ATEX1395X • IECEx per IECEx SIR 13.0167X •  Ex II 2G D • Ex db ed op is IIC T4 Gb • Ex tb op is IIIC T96°C Db • (-55°C ≤ Ta ≤ +75°C) | OR | <ul style="list-style-type: none"> •  Ex II 2G D • Ex db eb op is IIC T4 Gb • Ex tb op is IIIC T106°C Db • (-55°C ≤ Ta ≤ +85°C) |
|--|-----------|--|

This product is suitable to use in hazardous zones 1 and 2 with IIC gas group vapors present, and zones 21 and 22 with IIIC dust type present.

1.4.5.2 FM, CSA

The FV-40 Series Flame Detectors are approved to FM Explosion Proof and FM Functionality approved per FM3260:

- Class I, Division 1, Groups B, C and D, T5 Ta = 85°C.
- Dust Ignition Proof – Class II/III Division 1, Groups E, F and G.
- Ingress Protection – IP67, IP66, NEMA 250 Type 6P.
- Fuel Test Response including: Gasoline, N-Heptane, Diesel, JP5, Kerosene, Ethyl, Alcohol 95%, IPA, Methanol, Methane, LPG, Polypropylene, and Paper.

1.4.5.3 SIL-2 Approved (TÜV)

The FV-40 Series Flame Detector are pending to SIL-2 requirement per IEC 61508-4, Chapter 3.5.12.

The alert condition according to SIL-2 can be implemented by:

- Alert signal via 0-20mA current loop.
- or
- Alert signal via alarm relay and fault relay.
- For more details and guidelines for configuring, installing, operating, and service, see *SIL-2 Features* on page 83 and TÜV Report No. 968/EZ 636.00/13.

1.4.5.4 EN54-10

The FV-40 Series Flame Detectors are pending to EN54-10 and CPD.

- The detector has been tested and approved per EN54-10 by VdS (Germany).
- This test includes functional test, environmental test, EMI/EMC test and software check.

1.4.5.5 INMETRO (UL)

- The FV-40 Flame Detector is in compliance with the standards ABNT NBR IEC 60079-0, ABNT NBR IEC 60079-1, ABNT NBR IEC 60079-7, ABNT NBR IEC 60079-31 and INMETRO decree No. 179 as of May 18th, 2010.
- Further details may be found on Certificate of Compliance No. UL-BR 16.0652X

1.5 Performance Considerations

This section describes performance aspects of the FV-40 Series Detectors and includes:

- Detection Sensitivity
- Cone of Vision
- False Alarms Prevention
- Visual Indicators
- Output Signals
- Detector Status
- Auxiliary Relay as End-of-Line Resistor

1.5.1 Detection Sensitivity

Detection sensitivity is the maximum distance at which the detector reliably detects a specific size of fire and typical type of fuel (standard fire).

1.5.1.1 Standard Fire

Defined as a 1ft² / 0.1m² n-heptane pan fire, with maximum wind speed of 6.5 ft./sec (2 m/sec).

1.5.1.2 Sensitivity Ranges

The detector has two response levels:

- WARNING (Pre-alarm)
- ALARM

The detection distance, for the WARNING level, is approximately 10% higher than the ALARM distance.

For some typical ambient conditions the Zeta parameter as defined in NFPA 72 for the detector is 0.005 (1/meter).

All Models except F4-UF

Table 4: Detector Sensitivity Range Levels

| Level | Response Time (sec) | Sensitivity Range- ft. (m) |
|-----------|---------------------|----------------------------|
| 1 | 3 | 50 (15) |
| 2 Default | 5 | 100 (30) |
| 3 | 8 | 150 (45) |
| 4 | 10 | 215 (65) |

Model F4-UF Ultra Fast UV/IR

The default detection distance for the ALARM level is 65 ft. (20m) from a standard fire

Note: Zeta parameters may vary significantly with changes in temperature, air pressure, humidity, visibility conditions, and so on.

1.5.1.3 Other Fuels

The detector reacts to other types of fire as follows:

- The baseline fire refers to n-heptane 1ft² (0.1m²) and is defined as 100% sensitivity.
- For fuel fire – standard pan fire size: 1 ft² (0.1 m²).
- For gas flame - 20 inch (0.5m) high, 8 inch (0.2m) width plume fire.
- Maximum Response Time: 10 sec. (3 sec. for Model F4-UF).

Table 5: Fuel Sensitivity Ranges

| Type Of Fuel | Max. Distance (ft./m) | Max. Distance (ft./m) | Max. Distance (ft./m) |
|---------------|-----------------------|----------------------------------|---------------------------|
| | Model F4-I3, F4-MM | Model F4-2V, F4-2B, F4-UV, F4-VB | Model F4-UF, F4-4V, F4-4B |
| Gasoline | 215 / 65 | 50/15 | 65/28 |
| N-Heptane | 215 / 65 | 50/15 | 65/20 |
| JP5 | 150 / 45 | 37/11 | 42/14 |
| Kerosene | 150 / 45 | 37/11 | 42/14 |
| Diesel Fuel | 150 / 45 | 37/11 | 40/13.5 |
| Ethanol 95% | 135 / 40 | 37/11 | 23/7 |
| IPA | 135 / 40 | 37/11 | 43/13 |
| Methanol | 115 / 35 | 37/11 | 26/8 |
| Methane | 100 / 30 | 40/12 | 16/5 |
| LPG | 100 / 30 | 40/12 | 16/5 |
| Paper | 33 / 10 | 20/6 | 16/5 |
| Polypropylene | 16 / 5 | 18/5 | 16/5 |
| Hydrogen | 100 / 30 | 33/10 | 23/7 |
| Ammonia | 40 / 12 | | 16/5 |
| Silane | 16 / 5 | 22/7 | 20/6 |

1.5.2 Cone of Vision

- See Technical Specifications in Appendix A.1

1.5.3 False Alarms Prevention

To prevent false alarms, the detector will not alarm or react to the radiation sources specified in Table 6.

Table 6: False Alarms Prevention

| Radiation Source | F4-I3, F4-MM Immunity Distance ft. (m) | F4-UV, F4-VB Immunity Distance ft. (m) | F4-2V, F4-2B, F4-4V, F4-4B, F4-UF Immunity Dist ft.(m) |
|--|--|--|---|
| Indirect or reflected sunlight | IAD | IAD | IAD |
| Vehicle headlights (low beam) conforming to MS53023-1 | IAD | IAD | IAD |
| Incandescent frosted glass light, 300 W | IAD | IAD | IAD |
| Fluorescent light with white enamel reflector, standard office or shop, 70 W (or two 35 W) | IAD | IAD | IAD |
| Electric arc [12mm (¹⁵ / ₃₂ ") gap at 4000 V alternating current, 60 Hz] | IAD | IAD | IAD |
| Arc welding [6 mm (⁵ / ₁₆ ") rod; 210 A] | Table 7: Welding Immunity Distance | | 9.8 (3) |
| Ambient light extremes (darkness to bright light with snow, water, rain, desert glare and fog) | IAD | IAD | IAD |
| Bright colored clothing, including red and safety orange | IAD | IAD | IAD |
| Electronic flash (180 watt-seconds minimum output) | IAD | | IAD |
| Movie light, 625 W quartz DWY lamp (Sylvania S.G.-55 or equivalent) | >6.5 (2) | | >6.5 (2) |
| Blue-green dome light conforming to M251073-1 | IAD | IAD | IAD |
| Flashlight (MX 991/U) | IAD | IAD | IAD |
| Radiation heater, 3000 W | >3 (1) | IAD | IAD |
| Radiation heater, 1000 W with fan | IAD | IAD | IAD |
| Quartz lamp (1000 W) | >3 (1) | | 12 (4) |
| Mercury vapor lamp | IAD | | IAD |
| Grinding metal | IAD | | 3.3 ft. (1) |
| Lit cigar | >1 (0.3) | 5 (1.5) | IAD |

| Radiation Source | F4-I3, F4-MM Immunity Distance ft. (m) | F4-UV, F4-VB Immunity Distance ft. (m) | F4-2V, F4-2B, F4-4V, F4-4B, F4-UF Immunity Dist ft.(m) |
|---------------------------------------|--|--|--|
| Lit cigarette | >1 (0.3) | 5 (1.5) | IAD |
| Match, wood, stick including flare up | >13 (4) | 16.5 (5) | 3.3 ft. (1) |

Notes: (See next page)

- IAD = Immune at Any Distance.
- All sources are chopped from 0 to 20 Hz.

Table 7: Welding Immunity Distance

| Sensitivity Setting | Detection Range | Immunity Distance |
|---------------------|-----------------|-------------------|
| 1 | 50 ft. (15m) | >6 ft. (2m) |
| 2 | 100 ft. (30m) | >12 ft. (4m) |
| 3 | 150 ft. (45m) | >17 ft. (6m) |
| 4 | 215 ft. (65m) | >25 ft. (7.5m) |

1.5.4 Visual Indicators

One 3-color LED indicator is located inside the detector window, as shown in Figure 1. The detector statuses are listed below.

Table 8: LED Indications

| Detector Status | LED color | LED mode |
|------------------|-----------|-----------------|
| Fault, BIT Fault | Yellow | 4 Hz - flashing |
| Normal | Green | 1 Hz - flashing |
| Warning | Red | 2 Hz - flashing |
| Alarm | Red | Steady |

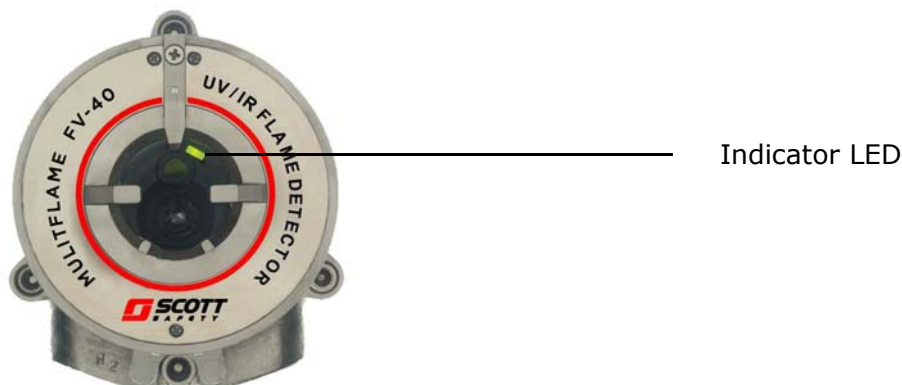

Figure 1: Indication LED

1.5.5 Output Signals

Outputs are available according to the default configuration or the wiring options selected for the FV-40 series detector. Determine the outputs for your model according to Table 9.

The detector incorporates several types of output suitable to different control systems:

- 0-20mA (stepped) with HART
- Relays (Alarm, Fault, Auxiliary)
- RS-485 Modbus
- Model F4-UF Analog Output – analog output proved ultra-fast detection to comply with 20 msec detection.

Table 9: Available Output Types

| Output Type | Version | Detector Status |
|-----------------------|----------------------------|--|
| Alarm relay | Wiring Option: 1 or 4 or 5 | The relay is N.O. |
| | Wiring Option: 2 or 3 | The relay is N.O. and N.C. |
| Auxiliary relay | Wiring Option: 4 or 5 | The relay is N.O. |
| Fault relay | Wiring Option: 1 or 2 or 4 | The relay is N.C. energized |
| | Wiring Option: 3 or 5 | The relay is N.O. energized |
| 0-20mA Current Output | Wiring Option: 1 | SINK Option, (can be changed to Source – see Figure 8, Figure 9 and Figure 10) |
| | Wiring Option: 2 or 3 | SOURCE Option with the HART protocol |
| RS-485 | All versions | Modbus protocol |
| Analog Output | All Versions | 0 V during Normal 5 V during detection |

1.5.6 Detector Status

Failure to understand the detector statuses and their outputs could lead to serious injury or death.

The possible detector function statuses are listed in Table 10:
Detector Status

A more detailed fault analysis can be seen via HART or RS485.

Table 10: Detector Status

| Status | Description |
|--------------------------|--|
| Normal | Normal operation. |
| BIT | Built-In-Test being performed. |
| Warning | Fire detected - changed to Warning (pre-alarm state). |
| Alarm | Fire detected - changed to Fire Alarm state. |
| Latched Alarm (Optional) | The alarm outputs remain latched on following detection of a fire that has already been extinguished. |
| BIT Fault | A fault is detected during BIT sequence or other electric failure. The detector will continue to detect for fire. |
| Fault | A fault is detected when the power supply is too low or due to a software fault or electrical failure. The detector will NOT detect fire in this condition. |

In each state, the detector activates different outputs, as specified in Table 11.

Table 11: Output Signals versus Detector State

| Detector State | LED Indicator | LED Mode | Alarm Relay | Auxiliary Relay | Fault Relay | mA output |
|--------------------------|---------------|----------|-------------|-------------------|-------------|-----------|
| Normal | Green | 1Hz | Off | Off | On | 4 mA |
| Warning | Red | 2Hz | Off | On ⁽⁴⁾ | On | 16 mA |
| Alarm ⁽¹⁾ | Red | Constant | On | On | On | 20 mA |
| Latch ⁽²⁾ | Red | Constant | On | Off | On | 20 mA |
| | | | | On ⁽⁴⁾ | On | 20 mA |
| BIT Fault ⁽³⁾ | Yellow | 4Hz | Off | Off | Off | 2 mA |
| Warning at BIT Fault | Red | 2Hz | Off | On ⁽⁴⁾ | Off | 16 mA |
| Alarm at BIT Fault | Red | Constant | On | On | Off | 20 mA |
| Fault | Yellow | 4Hz | Off | Off | Off | 0 mA |

Notes:

The alarm outputs are activated while alarm conditions exist and will stop approximately 5 seconds after the fire is no longer detected.

The alarm state can be optionally latched via programmed function. (Default is non-latching).

The detector will remain in BIT Fault state until it has passed a successful BIT.

The Auxiliary Relay can be activated at the Warning level or Alarm level, depending on programmed function.

The outputs depend on the wiring options.

1.5.6.1 Optional Latching

Alarms are set as non-latching by default. However, the detector includes a latched alarm output capability, which operates according to the programmed function.

If selected, upon detection of a fire, the detection signal is latched until a manual reset is performed (disconnecting the power supply or performing a manual BIT).

Latching affects the Alarm Relay, 0-20mA output, the Alarm LED (the Auxiliary Relay will be latched only when the programmable function **Auxiliary Relay** is set to **YES**).

Notes:

- The Auxiliary Relay is available only in Models with Wiring Option: 4 or 5
- The 0-20mA is available only in Models with Wiring Option: 1 or 2 or 3

1.5.7 Auxiliary Relay as End-of-Line Resistor

The Auxiliary Relay can be used as End-of-Line (EOL) resistance in Models with Wiring Option: 4 or 5 only. In this case, the Auxiliary Relay is active as long as the detector is not in Fault state.

1.6 Internal Detector Tests

The detector performs two types of self-tests:

- Continuous **Feature Test**
- Built-In-Test (BIT)

Continuous Feature Test

During normal operation, the detector tests itself continuously and indicates a fault if a failure is found. This type of test complies with SIL-2 requirements.

The detector continuously tests:

- Input voltage level
- All internal regulator voltage level
- Voltage level status of sensor and sensor circuitry for noise or disconnection in the electronic circuitry
- 0-20mA level output
- Relays and heater operation
- Processor Watchdog

- Software
- Memory
- Oscillator frequency

Response to Fault Indication

If a failure is found, the detector indicates by:

- Fault relay:
 - Opens in wiring option: 1 or 2, and 4
 - Closes in wiring option: 3 and 5
- 0-20mA: indicates Fault (0mA or 2mA) in wiring option: 1 or 2 or 3
- LED – Yellow flashes (4 Hz)
- Correcting the Fault

The fault indications remain until the detector's power is removed. The fault indications return if the fault is still found when power is restored.

1.6.1 Built-In-Test (BIT)

The detector's Built-In-Test (BIT) also checks the following:

- Electronics circuitry
- Sensors
- Window cleanliness

The detector can be set to perform the BIT automatically.

1.6.1.1 How the BIT Operates

- The detector's status remains unchanged if the result of a BIT is the same as the current status (NORMAL or BIT Fault)
- The detectors' status is changed (from Normal to BIT Fault or vice versa) if the BIT differs from the current status

Note: In 'BIT Fault' status the detector can continue to detect a fire.

1.6.1.2 Automatic BIT

The detector automatically performs a BIT every 15 minutes. A successful BIT sequence does not activate any indicator.

All outputs of BIT results function as described in Table 12 and Table 13.

Table 13: Results of an Unsuccessful BIT, and the BIT is automatically executed every 1 minute. This continues until a successful BIT occurs, when the detector resumes normal operation.

Table 12: Result of a Successful BIT

| Output | Result |
|---------------|--|
| Fault relay | <ul style="list-style-type: none"> Wiring Option: 1- or 2- or 4- remains CLOSED Wiring Option: 3- or 5- remains OPEN |
| 0-20mA output | Wiring Option: 1- or 2- or 3- Normal (4 mA) |
| Power LED | Green, Flashing, 1 Hz On (Normal) |

Table 13: Results of an Unsuccessful BIT

| Output | Result |
|---------------|--|
| Fault relay | <ul style="list-style-type: none"> Wiring Option: 1- or 2- or 4- changes to Open Wiring Option: 3- or 5- changes to Closed |
| 0-20mA output | Wiring option 1, 2, 3: BIT Fault (2mA) |
| Power LED | Yellow, Flashing, 4 Hz |
| BIT procedure | Performed every 1 minute |

1.6.1.3 Manual BIT

The BIT is manually initiated by momentarily connecting Terminal 3 with Terminal 2 (or a switch across these terminals in the safe area).

The results of a successful and unsuccessful Manual BIT are listed in Table 14 and Table 15.

Table 14: Results of a Successful Manual BIT

| Output | Result |
|-----------------|--|
| FAULT relay | <ul style="list-style-type: none"> Wiring options: 1 or 2 or 4 remains CLOSED (Normal) Wiring options: 3 and 5 remains OPEN (Normal) |
| ALARM relay | Activated for 3 sec (only when the function Alarm BIT is set to YES) |
| AUXILIARY relay | For wiring options: 4 and 5 is activated for 3 sec (only when the function Auxiliary BIT is set to YES) |
| 0-20mA output | Wiring option: 1 or 2 or 3 <ul style="list-style-type: none"> Initiates 20 mA only when the function Alarm BIT is set to YES Initiates 16 mA when the function Auxiliary BIT is set to YES and the function Alarm BIT is set to NO |
| POWER LED | Green, Flashing, 1 Hz |

Table 15: Results of an Unsuccessful Manual BIT

| Output | Result |
|---------------|--|
| FAULT relay | <ul style="list-style-type: none"> Wiring option: 1 or 2 or 4 changes to OPEN Wiring option: 3 and 5 changes to CLOSED |
| 0-20mA output | Wiring option: 1 or 2 or 3 Indicates BIT FAULT (2mA) |
| POWER LED | Yellow, Flashing, 4 Hz |

1.6.1.4 Manual BIT only selected

The BIT is initiated manually by momentarily connecting Terminal Number 3 with Terminal Number 2 or a switch across these terminals in the safe area.

2 Installing the Detector

➤ **In this chapter...**

General Guidelines

Unpacking the Product

Required Tools

General Instructions

Installation Cables

Installing the Tilt Mount

Connecting the Detector

Configuring your Detector

This chapter provides basic guidelines for installing the detector. It does not attempt to cover all of the standard practices and codes of installation. Rather, it emphasizes specific points of consideration and provides some general rules for qualified personnel. Wherever applicable, special safety precautions are stressed.



Warning: Installation work should be performed in a Non-Hazardous and safe environment, **failure to do so could lead to serious injury or death.**

Failure to properly install this equipment could lead to malfunctions and **may result in serious injury or death.**

Failure to operate this equipment in accordance with this User Guide **may result in serious injury or death.**

2.1 General Guidelines

To ensure optimal performance and an efficient installation, consider the following guidelines:

- **Sensitivity:** To determine the level of sensitivity, consider the following:
 - Size of fire at the required distance to be detected
 - Type of flammable materials

- **Wiring:**
 - The wire gauge must be designed according to the distance from the detector to the controller and the number of detectors on the same power line. See *Wiring Instructions*.

- To fully comply with EMC directive and protect against interference caused by RFI and EMI, the cable to the detector must be shielded and the detector must be grounded. The shield should be grounded at the detector end.
- **Spacing and Location:** The number of detectors and their locations in the protected area are determined by:
 - Size of the protected area
 - Sensitivity of the detectors
 - Obstructed lines of sight
 - Cone of view of the detectors
- **Environment:**
 - Dust, snow or rain can reduce the detectors sensitivity and require more maintenance activities.
 - The presence of high intensity flickering IR sources may affect sensitivity.
- **Aiming the Detector:**
 - The detector should be aimed toward the center of the detection zone and have a completely unobstructed view of the protected area.
 - Whenever possible, the detector face should be tilted down at a 45° angle to maximize coverage and prevent accumulation of dust and dirt.
 - Do not start an installation unless all conceivable considerations regarding detection location have been taken into account.

Installation should comply with **NFPA 72E or any other local and International regulations and standards**, as applicable to flame detectors and installation of Ex approved products.

2.2 Unpacking the Product

Upon receipt of your detector, check and record the following:

- A. Verify the appropriate Purchase Order.
- B. Record the Part Number (P/N) and Serial Number of the detectors, and the installation date in an appropriate Log-book.
- C. Open the package before installation and visually inspect the detector.
- D. Verify that all components required for the detector installation are readily available before beginning the installation.
- E. If the installation is not completed in a single session, secure and seal the detectors and conduits / cable entries.

2.2.1 Checking the Product Type

Check that your product has the configuration / options that you ordered. Check the detailed part number on the label and compare this information with the descriptions contained in *Model and Types*.

2.3 Required Tools

The detector can be installed using general-purpose common tools and equipment.

Table 16 lists the specific tools required to install the detector.

Table 16: Tools

| Tool | Function |
|--------------------------|--|
| Hex Key ¼ inch | Mount the detector on the tilt mount |
| Hex Key ³/₁₆ inch | Open and close detector cover (for wiring) |
| Flat Screw Driver 4 mm | Connect ground terminal |
| Flat Screw Driver 2.5 mm | Connect wires to the terminal blocks |

For wiring, use color-coded conductors or suitable wire markings or labels. 12 to 20 AWG (0.5 mm² to 3.5 mm²) wires may be used for site wiring. The selection of wire gauge should be based on the number of detectors used on the same line and the distance from the control unit, in compliance with specifications (see *General Instructions for Electrical Wiring*).

2.4 General Instructions



Warning: Do not open the detector, even when isolated, when flammable atmosphere present. **Failure to do so may result in serious injury or death.**

2.4.1 Special Instructions for Safe Use

The dimensions of the flame paths are other than the relevant minimum or maximum, as required by Table 2 of EN 60079-1:2014, as detailed below:

Table 17: Flame path dimensions

| Flame path Location | Type of Joint Maximum Gap, ic | Minimum Length, L |
|-------------------------|-------------------------------|-------------------|
| Sapphire Window Flanged | 0.04mm | 10.5mm |
| Main Spigot Cylindrical | 0.15mm | 15.5mm |

Gaps, ic, should not be modified to be any larger, and lengths, L, should not be modified to be any shorter than the values shown in the table above.

- Units may be painted or fitted with optional accessories, some of which are made of a non-metallic material or have a non-metallic coating which could potentially generate an ignition-capable level of electrostatic charge under certain extreme conditions. Therefore, these units should not be installed in a location where they may be subjected to external conditions (such as high-pressure steam) which might cause a build-up of electrostatic charges on the non-conducting surfaces. Cleaning of the equipment (except window) should be done only with a damp cloth.
- The 3 fastening screws used to screw on the cover of the flameproof compartment have a yield stress of 344N/mm². Any replacement fasteners must have a yield stress of at least this value.
- When the duct mount is fitted and the equipment is intended to be mounted to a heated/cooled air duct/process vessel, it should be verified that the temperature of the air duct/process vessel should not be capable of heating or cooling any part of the equipment enclosure to a temperature outside the marked maximum ambient temperature range prior to switching the equipment on, when taking into account surrounding ambient temperature.

Use the following certification instructions:

- The cable entry point may exceed 167°F (75°C). Suitable precautions should be taken when selecting the cable.
- The equipment may be used with flammable gases and vapors with apparatus groups IIA, IIB and IIC:
 - T5 in the ambient temperature range: -67°F (-55°C) to +167°F (+75°C).
 - T4 in the ambient temperature range: -67°F (-55°C) to +185°F (+85°C).
- Installation shall be carried out by suitably trained personnel in accordance with the applicable code of practice such as EN 60079-14:1997.
- Inspection and maintenance of this equipment shall be carried out by suitably trained personnel in accordance with the applicable code of practice such as EN 60079-17.
- Repair of this equipment shall be carried out by suitably trained personnel in accordance with the applicable code of practice such as EN 60079-19.
- The certification of this equipment relies upon the following materials used in its construction:
 - **Enclosure:** 316L Stainless Steel or Aluminum
 - **Window:** Sapphire Glass
- If the equipment is likely to come into contact with aggressive substances, then it is the responsibility of the user to take suitable precautions that prevent it from being adversely affected, thus ensuring that the type of protection provided by the equipment is not compromised:
 - Aggressive substances: acidic liquids or gases that may attack metals, or solvents that may affect polymeric materials.
 - Suitable precautions: regular checks as part of routine inspections or establishing from the material's data sheets that it is resistant to specific chemicals.

2.5 Installation Cables

Follow the following guideline for the cable installation:

- All cables to the detector must be well shielded in order to comply with EMC requirement (see
- *Insert* the battery into the flame simulator.
- A. Screw on the locking disc (Item 3).
- B. Screw on the back cover (Item 4).
- C. Lock the back cover with the locking screw.
- Technical Specifications).
- Ground the detector to the nearest ground point (not more than 3 meters or 40 feet from the detector location).
- Install the detector with the cable entries placed downwards.

2.5.1 Conduit Installation

The conduit used for the cabling must comply with the following:

- To avoid water condensation water in the detector, install the detector with the conduits placed downward, that include drain holes.
- When using the optional tilt mount, use flexible conduits for the last portion connecting to the detector.
- For installations in atmospheres as defined in group B of the NFPA 72E, seal the conduits inlets.
- When pulling the cables through the conduits, ensure that they are not tangled or stressed. Extend the cables about 30 cm. (12 in.) beyond the detector location to accommodate wiring after installation.
- After the conductor cables have been pulled through the conduits, perform a continuity test.

2.6 Installing the Tilt Mount

The Tilt Mount (part no. 093-0543) enables the detector to be rotated up to 60° in all directions. Figure 2 shows the Detector mounted on the Tilt Mount.

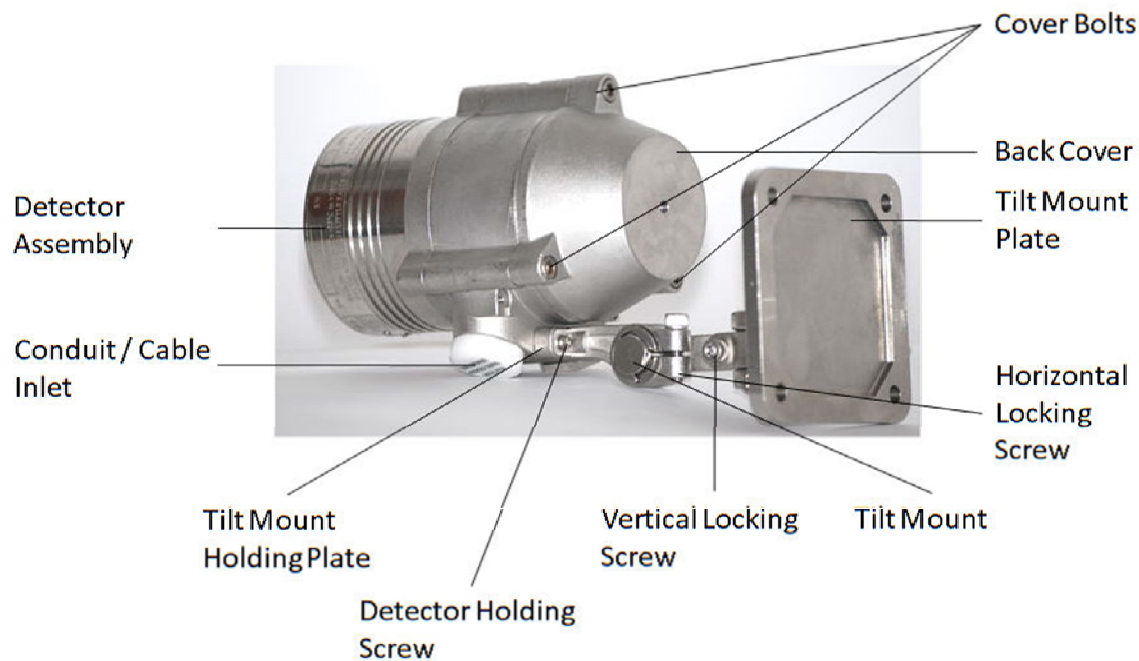

Figure 2: Detector with Tilt Mount

2.6.1 Tilt Mount Assembly

Figure 3 shows the Tilt Mount Assembly.

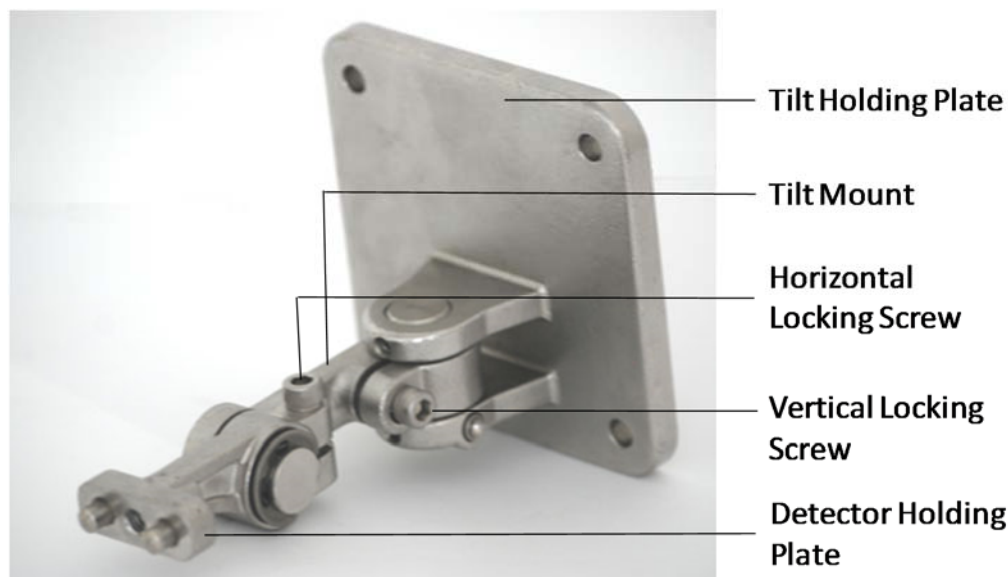

Figure 3: Tilt Mount Assembly

Figure 4 shows the Tilt Mount Assembly with dimension in both millimeters and inches.

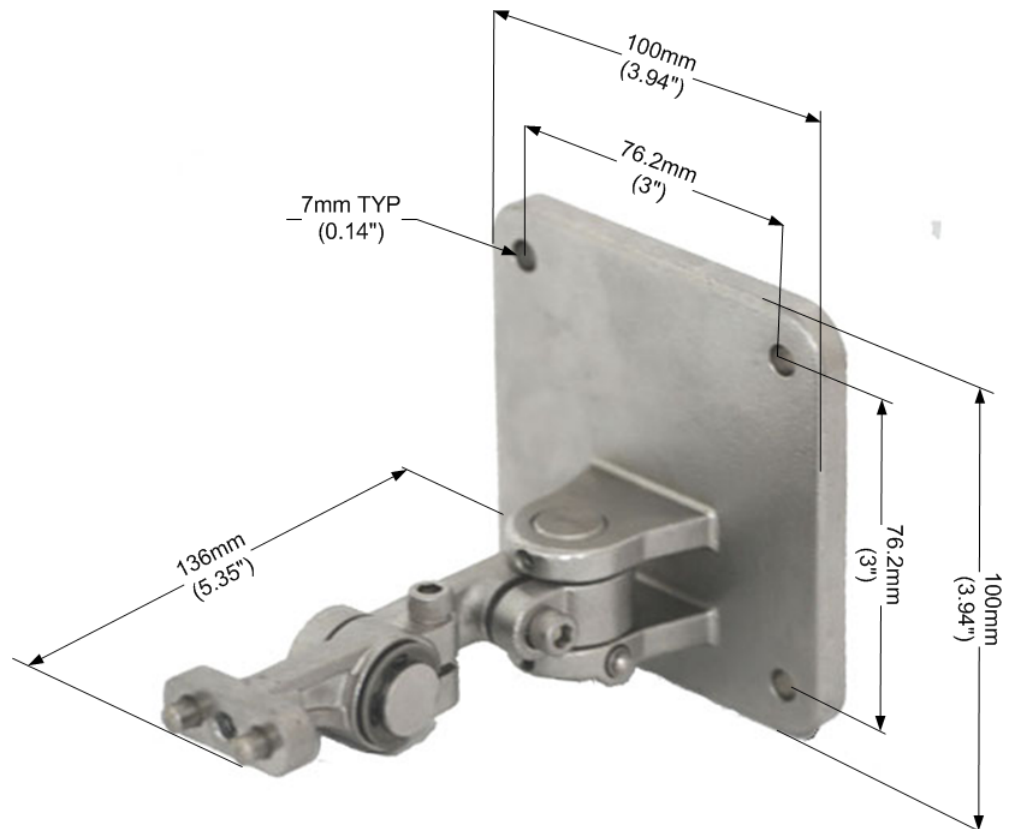

Figure 4: Tilt Mount Assembly (dimensions in mm and inches)

➤ **To install the Tilt Mount and Detector:**

- A. Place the tilt mount in its designated location and secure it with four (4) fasteners through four (4) holes 7 mm in diameter. Use the four (4) screws and spring washers provided, or adequate hardware of your own choosing. **Note:** Removing the detector for maintenance purpose does not require the Tilt Mount to be removed).
- B. Unpack the detector.
- C. Place the detector with its conduit/cable entries pointing downwards on the holding plate of the tilt mount. Secure the detector with $\frac{5}{16}$ " 18 UNC x 1" screw to the tilt mount.
- D. Release the Horizontal and Vertical Locking Screws using $\frac{3}{16}$ " Hex Key such that the detector can be rotated. Point the detector towards the protected area and make certain that the view of the area is unobstructed.
- E. Secure the detector in that position by tightening the locking screws on the tilt mount. (Make sure the detector is in the correct position.)

The detector is now correctly located, aligned and ready to be connected to the system.

2.7 Connecting the Detector

This section describes how to connect the electric cabling to the detector (figure 7).

➤ **To connect the detector to the electrical cables**

- A. Disconnect the power.
- B. Remove the back cover of the detector by removing four (4) socket head-screws in the cover bolts. The terminal chamber is now revealed.
- C. Remove the protective plug mounted on the Detector Conduit/Cable entry; pull the wires through the Detector Inlet.
- D. Use a $\frac{3}{4}$ " – 14 NPT explosion-proof conduit connection or M25x1.5 flameproof gland to assemble the cable / conduit to the detector. Connect the wires to the required terminals on the Terminal Board according to the wiring diagram Figure 6 and Table 30.
- E. Connect the grounding (earth) wire to the ground (earth) screw outside the detector (Earth Terminal). The detector must be well grounded to earth ground.
- F. Verify the wiring. Improper wiring may damage the detector. Check the wires for secure mechanical connection and press them neatly against the terminal to prevent them from interfering while closing the back cover Figure 6.
- G. Place and secure the detector's back cover by screwing the three (3) socket-head-screws in the Cover Bolts Figure 2.

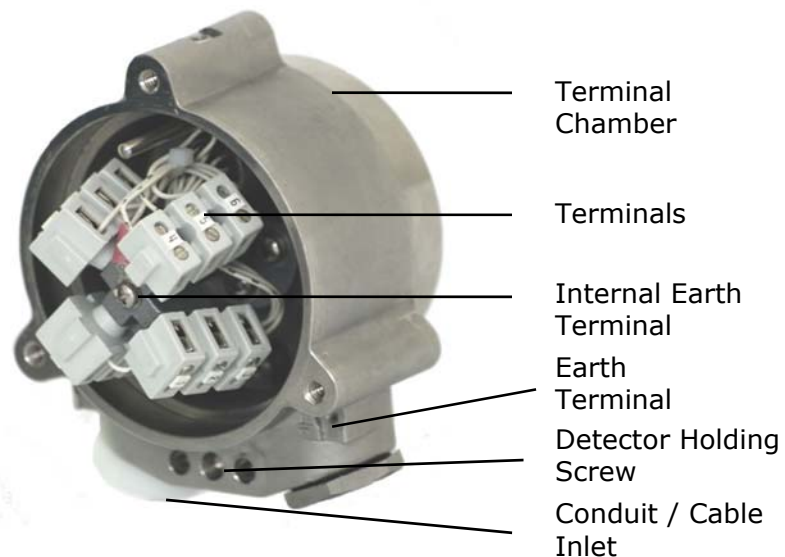

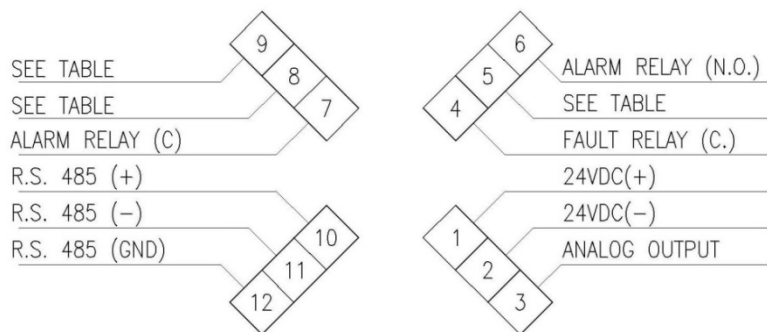

Figure 5: Detector with Cover Removed

2.7.1 Verifying the Detector Wiring

The detector has five output wiring options within the Exde integral terminal section of the enclosure. There are 12 terminals labeled 1-12.

Table 18 describes the function of each terminal for all the wiring options.

Table 18: FV-40 Series Wiring Options

| Wire Terminal No. | Option 1 Default | Option 2 | Option 3 | Option 4 | Option 5 |
|-------------------|------------------|------------------|------------------|------------------|------------------|
| 1 | +24 VDC | +24 VDC | +24 VDC | +24 VDC | +24 VDC |
| 2 | 0 VDC | 0 VDC | 0 VDC | 0 VDC | 0 VDC |
| 3 | Analog Output | Analog Output | Analog Output | Analog Output | Analog Output |
| 4 | Fault Relay N.C. | Fault Relay N.C. | Fault Relay N.O. | Fault Relay N.C. | Fault Relay N.O. |
| 5 | | | | | |
| 6 | Alarm Relay N.O. | Alarm Relay N.O. | Alarm Relay N.O. | Alarm Relay N.O. | Alarm Relay N.O. |
| 7 | Alarm Relay C | Alarm Relay C | Alarm Relay C | Alarm Relay C | Alarm Relay C |
| 8 | 0-20mA In | Alarm Relay N.C. | Alarm Relay N.C. | Auxiliary N.O. | Auxiliary N.O. |
| 9 | 0-20mA Out | 0-20mA Out* | 0-20mA Out* | Auxiliary C | Auxiliary C |
| 10 | RS-485+ (1) | RS-485+ (1) | RS-485+ (1) | RS-485+ (1) | RS-485+ (1) |
| 11 | RS-485- (1) | RS-485- (1) | RS-485- (1) | RS-485- (1) | RS-485- (1) |
| 12 | RS-485 GND | RS-485 GND | RS-485 GND | RS-485 GND | RS-485 GND |

*Available with the HART protocol.

Notes:

- RS-485 is used for communication network as specified in *Appendix C* (Terminals 10, 11, 12) and to connect (in safe area) to PC/Laptop for configuration/diagnostics.
- Alarm relay:
 - N.O. de-energized contact in wiring options 1 or 4 or 5.
 - N.O. and N.C. de-energized in options 2 and 3.
- 0-20mA is 'Sink' in option 1 and 'Source' in option 2 and 3.
- 0-20mA 'Source' in options 2 and 3 available with the HART protocol.
- In Wiring Option 1, link Terminals 1 and 8 to change the mA output to 'Source'.
- The Fault output is N.C. energized SPST relay. The contacts are closed when the Detector is in its normal operational condition in options 1 or 2 and 4, and available as N.O. energized in options 3 and 5.
- The Auxiliary output is N.O. energized (SPST) relay. The Auxiliary Relay may act in parallel with the ALARM relay to activate another external device or it may provide a warning signal, depending on the function configuration.

2.8 Configuring your Detector

Failure to follow these instructions could result in an incorrect configuring of the detector which could lead to serious injury or death.

You can reprogram the function setup using the RS-485 connection or using the HART protocol as follows:

- **USB RS485 Harness Kit** (P/N 8000453): The USB RS-485 Harness Kit with RS485/USB converter, used with the Scott Safety host software, enables you to connect to any available PC or laptop to re-configure settings or perform diagnostics on all FV-40 series flame detectors.

Refer to manual 087-0058 for programming instructions when using the USB RS485 Harness Kit.

- **HART Protocol:** Refer to Manual 087-0057 for programming instructions.

These functions enable you to set:

- Sensitivity
- Alarm Delay
- Address Setup
- Mode of Operation
- Heated Optics Operation

The factory Default settings listed for each function are:

- Sensitivity – 30
- Alarm Delay – 3 Sec.
- Alarm Latch – No
- Auxiliary Relay – No
- Automatic BIT – Yes
- Alarm BIT – No
- Auxiliary BIT – No
- EOL – No
- Heated Optics – Auto
- Temperature – 41°F (5°C)

2.8.1 Sensitivity

The detector offers four (4) sensitivity settings. The settings refer to an n-heptane or gasoline fire of 1ft² (0.1m²), from low sensitivity of 50 ft. (15m) to 215 ft. (65m). For other types of fuel sensitivity, refer to Table 5.

Table 19: Sensitivity Settings

| Sensitivity Setting | Detector Distance feet | Detector Distance meters |
|---------------------|------------------------|--------------------------|
| 15 | 50 | 15 |
| 30 (default) | 100 | 30 |
| 45 | 150 | 45 |
| 60 | 215 | 65 |

2.8.2 Alarm Delay

The detector is equipped with an Alarm Delay option, which provides programmable time delays with settings at:

- Antiflare (default setting, except for FV-40 UF: Default = 0 seconds)
The Antiflare mode is selected to prevent false alarms in locations where fast flares may be present. The Time Delay for fire alarms in this mode ranges from 2.5 to 15 seconds (usually, less than 10 seconds).

Other delays settings are available:

- 0, 3, 5, 10, 15, 20 or 30 seconds

When an Alarm (Detection) level condition occurs, the detector delays the execution of the Alarm outputs by the specified period of time. The detector then evaluates the condition for 3 seconds. If the Alarm level is still present, the Alarm outputs are activated. If this condition no longer exists, the detector returns to its standby state.

The Alarm delay option affects the output relays and the 0-20mA. The LEDs and outputs indicate warning levels during the delay time only if the fire condition exists.

2.8.3 Address Set-up

The detector provides up to 247 addresses that can be changed with the RS485 communication link or the HART protocol.

2.8.4 Function Set-up

You can select the desired functions as detailed in Table 20.

Table 20: Functions

| Function | Setting |
|-------------------|---|
| Alarm Latch | <ul style="list-style-type: none"> • Yes: Enable Alarm latching. • No: Disable Alarm latching (default). |
| Auxiliary Relay** | <ul style="list-style-type: none"> • Yes: Activate Auxiliary Relay at Warning level. • No: Activate Auxiliary Relay at Alarm level (default). |
| Automatic BIT | <ul style="list-style-type: none"> • Yes: Perform Automatic & Manual Bit (default). • No: Perform Manual Bit only. |
| Alarm BIT | <ul style="list-style-type: none"> • Yes: Successful Manual Bit activates the Alarm Relay for approximately 3 seconds (default). • No: Successful Manual Bit does not activate the Alarm Relay. |
| Auxiliary BIT** | <ul style="list-style-type: none"> • Yes: Successful Manual Bit activates the Auxiliary Relay for approximately 3 seconds (default). • No: Successful Manual Bit does not activate the Auxiliary Relay. |
| EOL** | <ul style="list-style-type: none"> • Yes: Auxiliary Relay is used as End of Line. • No: Auxiliary Relay operates in accordance with Function 2 and 5 (default). |

Note: ** Only available in FV-40 with wiring option 4 and 5

2.8.5 Heated Optics

The heated optics can be defined as one of the following modes:

- Heated Mode
 - OFF: Not operated
 - On: Continuously
 - AUTO: Per temperature change

In AUTO mode, the default HEAT ON setting is 41°F (5°C). Heating stops when the temperature is 27°F (15°C) above the start temperature.

You can define the start temperature below which the window will be heated. The temperature can be defined between 32°F and 122°F (0°C to 50°C).

3 Operating the Detector

➤ **In this chapter...**

Powering Up

Safety Precautions

Testing Procedures

This chapter describes how to power up and test the detector. It also includes some very important safety checks that you should make before operating the detector.



Warning: If detector does not power up and operate according to the instructions in this manual, DO NOT USE. Tag out for repair. Use of an improperly operating detector may result in serious injury or death.

3.1 Powering Up

This section describes how to power up the detector. Follow these instructions carefully to obtain optimal performance from the detector over its life cycle:

➤ **To power up the detector:**

- A. Turn on the power.
- B. Wait approximately 60 seconds for the detector to finish the start-up procedure.

Applying power initiates the following sequence of events:

- The yellow LED flashes at 4 Hz.
- BIT is executed.

If successful, the green LED flashes at 1 Hz and the FAULT relay contacts close, output is 4 mA.

- C. Enter to Normal mode.

Note: The majority of detectors are used in the default non-latching alarm mode. Only perform a Reset when the Latching alarm option has been programmed.

➤ **To reset a detector when in it is in a LATCHED ALARM state:**

- Do one of the following:

- Disconnect power (Terminal Number 1 or Terminal Number 2).
or
- Initiate a Manual BIT.

3.2 Safety Precautions

After powering-up, the detector requires almost no attention in order to function properly, but the following should be noted:

- Follow the instructions in this guide and refer to the drawings and specifications.
- Do not expose the detector to radiation of any kind unless required for testing purposes.
- Do not open the detector housing, while power is applied.
- Do not open the electronic compartment. This part should be kept closed at all times and only opened in the factory. Opening the electronic component side invalidates the warranty.
- You should only access the wiring compartment to wire or remove the detector or access RS485 terminals for maintenance.
- Disconnect or disable external devices, such as automatic extinguishing systems before carrying out any maintenance.

3.2.1 Default Functions Settings

Table 21 lists the default function configuration supplied with the detector.

Table 21: Default Function Values

| Function | Value | Notes |
|-----------------|---------------|--|
| Sensitivity | 30 | Meters. |
| Alarm Delay | A | Antiflare. |
| Alarm Latch | No | |
| Auxiliary Relay | No | In wiring options 1, 2, 3 the Auxiliary Relay is not available. This function is not used. |
| Automatic BIT | Yes | |
| Alarm BIT | No | |
| Auxiliary BIT | No | In wiring options 1, 2, 3 the Auxiliary Relay is not available. This function is not used. |
| EOL | No | In wiring options 1, 2, 3 the Auxiliary Relay is not available. This function is not used. |
| Heat Mode | Auto | |
| Heat On | 41°F (5°C) | The detector starts heating the window for any temperature below this value (C°) |

- In order to change the default function use one of the following:
 - USB RS485 Harness Kit P/N 8000453. Refer to manual 087-0058 for programming instructions when using the USB RS485 Harness Kit.
 - HART protocol, refer to Manual 087-0057 for instructions.

3.3 Testing Procedures

This section describes the proof testing procedure for proper operation of the detector. The detector can be tested using the Manual Built-in-Test or the Scott Safety Flame Simulators.

The detector performs internal test continuously and automatic BIT test every 15 minutes for more details refer to *Built-In-Test (BIT)*.

This section includes the following topics:

- Automatic BIT Test
- Manual BIT Test
- Testing with Flame Simulators

3.3.1 Automatic BIT Test

Check that the indicators show normal conditions. See *Powering Up*.

3.3.2 Manual BIT Test

Important: If the function setup **Alarm BIT** and/or **Auxiliary BIT** are set to **Yes** (default **No**), the Alarm, Auxiliary Relay and 0-20mA outputs are activated during a Manual BIT. Therefore, automatic extinguishing systems or any external devices that may be activated during BIT **must** be disconnected.

➤ **To perform a Manual BIT:**

A. Verify that the detector is Normal Mode.

Initiate Manual BIT. The results of successful and unsuccessful manual BITs are detailed in Table 14 and Table 15.

3.3.3 Testing with Flame Simulators

The Flame Simulator Models 380114-1 (IR3), 380114-2 (UV/IR), 380114-3 (IR) and 380114-4 (Multi IR) are used to simulate exposure of the detector to a real fire condition. Depending on the model of Flame Detector in your installation, choose the proper Flame Simulator for your application. The detector is exposed to radiation at the required detection level by the simulator. As a result, the detector will generate a Fire Alarm signal.

Important: If the detector is exposed to a flame simulator, the Alarm and Accessory Relays and 0-20mA are activated during the simulation. Therefore, automatic extinguishing systems or any external devices, which may be activated during this process, must be disconnected *prior* to testing.

➤ **To perform Fire Simulator Test:**

- A. Power up the system and wait up to 60 seconds for the detector to turn to a normal state. The Power LED turns on.
- B. Aim the appropriate Scott Safety Flame Simulator (depending on the model type of your Flame Detector) at the target point of the detector (Figure 13), in a way that the radiation emitted by it is facing directly towards the detector. (See Long Range Flame Simulators).
- C. Press the operation button once. After few seconds, a successful test shows the results shown in Table 22.

Table 22: Results of Successful Fire Simulator Test

| Component | Action | Notes |
|-----------------|--------------------------------|--|
| 0-20mA | Turn to 20mA | For a few seconds and then return to 4mA |
| Analog Output | Turn to 5 V DC | Then return to 0 V |
| Alarm Relay | Activated | for a few seconds and then returns to Normal |
| Auxiliary Relay | Activated | for a few seconds and then returns to Normal |
| Fault Relay | Remains active during the test | |
| LED | Red, steady | |

The detector is now ready for operation.

4 Maintenance and Troubleshooting

➤ **In this chapter...**

Maintenance

Troubleshooting

This chapter deals with preventive maintenance, describes possible faults in detector operation and indicates corrective measures. Ignoring these instructions may cause problems with the detector and may invalidate the warranty. Whenever a unit requires service, please contact Scott Safety or its authorized distributor for assistance.

4.1 Maintenance

Failure to properly maintain your MultiFlame FV-40 Series Flame Detector could result in serious injury or death.

This section describes the basic maintenance steps that should be taken to keep the detector in good working condition and includes the following topics:

- General Procedures
- Periodic Procedures
- Keeping Maintenance Records

4.1.1 General Procedures

Maintenance should be performed by suitably qualified personnel, who are familiar with local codes and practice. Maintenance requires ordinary tools.

4.1.1.1 Cleaning

The detector must be kept as clean as possible. Clean the viewing window and the reflector of the Flame Detector periodically.

The frequency of cleaning operations depends upon the local environmental conditions and specific applications. The fire detection system designer will give his recommendations.

➤ **To clean the detector viewing window and reflector:**

- A. Disconnect power to the detector before proceeding with any maintenance including window/lens cleaning.
- B. Use water and detergent, and then rinse the viewing window with clean water.

- C. Where dust, dirt or moisture accumulates on the window, first clean it with a soft optical cloth and detergent, and then rinse with clean water again.
- D. Inspect the detector for signs of damage, wear, or chemical attack, loose fittings, corrosion or cracking. If evidence of damage is found, do not use. Tag-out for repair. Failure to maintain proper operation of detector may result in serious injury or death.

4.1.2 Periodic Procedures

In addition to preventive cleaning and maintenance, the detector should be functionally tested every six months or as dictated by local codes and regulations. These tests should also be carried out if the detector has been opened for any reason.

4.1.2.1 Power-Up Procedure

Perform Power-Up procedure every time power is restored to the system. Follow the instructions described in *Powering Up*.

4.1.2.2 Functional Test Procedure

Perform a functional test of the detector as described in *Internal Detector Tests*.

4.1.3 Keeping Maintenance Records

It is recommended that maintenance operations performed on a detector are recorded in a Log-book. The record should include the following:

- Installation date, and contractor
- Serial and tag no.
- Entries for every maintenance operation performed, including the description of the operation, date and personnel ID.

If a unit is sent to Scott Safety or a distributor for service, a copy of the maintenance records should accompany it.

4.2 Troubleshooting

This section is intended to be a guide to correct problems which may happen during normal operation.

Table 23: Troubleshooting Table

| Problem | Cause | Corrective Action |
|---|---|--|
| LEDs Off Fault Relay at N.O 0-20mA at 0mA | No power at the unit | <ul style="list-style-type: none"> • Check that the correct power is sent to the detector. • Check power polarity. • Check wiring in the detector. • Send the detector back for repairs. |
| Yellow LED flashes at 4 Hz Fault Relay at N.O 0-20mA at 0mA | Fault Detector <ul style="list-style-type: none"> • Low Voltage • Faulty Detector | <ul style="list-style-type: none"> • Check the voltage at the detector; verify at least 24V at the detector terminal. • Send the detector back for repairs. |
| Yellow LED flashes at 4 Hz Fault Relay at N.O 0-20mA at 2mA | BIT Fault <ul style="list-style-type: none"> • Faulty Detector | <ul style="list-style-type: none"> • Clean detector window. • Re-power the detector. • Replace the detector. |
| Red LED constantly on | If no fire exists, then, detector alarm latched | Perform Reset to the detector. |
| Alarm Relay at On 0-20mA at 20mA | Alarm condition | <ul style="list-style-type: none"> • Check cause for alarm. • If no alarm, re-power the detector. • Send the detector back for repairs. |

Appendices

A Specifications

Failure to review and understand the specifications for your model could result in serious injury or death.

➤ **In this appendix...**

Technical Specifications

Electrical Specifications

Outputs

Mechanical Specifications

Environmental Specifications

A.1 Technical Specifications

Please refer to the appropriate section depending on your detector model:

Triple IR F4-I3 / Multi IR F4-MM

| Spectral Response | Three IR Bands | | | |
|--|----------------|----------|----------------------------|----------|
| | Fuel | ft. / m | Fuel | ft. / m |
| Detection Range (at highest Sensitivity Setting for 1ft ² (0.1m ²) pan fire) | n-Heptane | 215 / 65 | Kerosene | 150 / 45 |
| | Gasoline | 215 / 65 | Ethanol 95% | 135 / 40 |
| | Diesel Fuel | 150 / 45 | Methanol | 115 / 35 |
| | JP5 | 150 / 45 | IPA (Isopropyl Alcohol) | 135 / 40 |
| | Methane* | 100 / 30 | Polypropylene Pellets | 16 / 5 |
| | LPG* | 100 / 30 | Office Paper | 33 / 10 |

* 20" (0.5m) high, 8" (0.2m) width plume fire

Response Time Typically 5 seconds.

Adjustable Time Delay Up to 30 seconds

Sensitivity Ranges 4 Sensitive ranges for 1 ft² (0.1m²) n-heptane pan fire from 50 ft. (15m) to 215 ft. (65m)

| | |
|----------------------------|--|
| Fields of View | Model F4-I3: Horizontal 100°, Vertical 95° Model F4-MM: Gasoline: Horizontal 67°, Vertical 70° Hydrogen: Horizontal 80°, Vertical 80° |
| Built-In-Test (BIT) | Automatic (and Manual) |

Dual Sensor UV/IR F4-2V, F4-2B, F4-4V, and F4-4B

| | |
|--------------------------|--|
| Spectral Response | F4-2V, F4-2B UV:0.185 – 0.260µm IR:2.5 - 3.0µm F4-4V, F4-4B UV:0.185 – 0.260µm IR:4.4 - 4.6µm |
|--------------------------|--|

| | | | | |
|--|-------------|----------------|---------------|----------------|
| F4-2V, F4-2B Detection Range (at highest Sensitivity Setting for 1ft ² (0.1m ²) pan fire) | Fuel | ft. / m | Fuel | ft. / m |
| | Gasoline | 50 / 15 | Methanol | 25 / 7.5 |
| | n-Heptane | 50 / 15 | Methane * | 15 / 4.5 |
| | JP5 | 37 / 11 | LPG * | 15 / 4.5 |
| | Kerosene | 37 / 11 | Paper | 15 / 4.5 |
| | Diesel Fuel | 37 / 11 | Polypropylene | 15 / 4.5 |
| | Ethanol 95% | 25 / 7.5 | Hydrogen* | 15 / 4.5 |
| | IPA | 25 / 7.5 | | |

* 20" (0.5m) high, 8" (0.2m) width plume fire

| | | | | |
|--|-------------|----------------|---------------|----------------|
| F4-4V, F4-4B Detection Range (at highest Sensitivity Setting for 1ft ² (0.1m ²) pan fire) | Fuel | ft. / m | Fuel | ft. / m |
| | Gasoline | 66 / 20 | IPA | 52 / 16 |
| | n-Heptane | 92 / 28 | Methanol | 39 / 12 |
| | JP5 | 49 / 15 | Methane * | 26 / 8 |
| | Kerosene | 49 / 15 | LPG * | 23 / 7 |
| | Diesel Fuel | 49 / 15 | Paper | 23 / 7 |
| | Ethanol 95% | 39 / 12 | Polypropylene | 16 / 5 |

* 20" (0.5m) high, 8" (0.2m) width plume fire

| | |
|------------------------------|--|
| Response Time | Typically 5 seconds for models F4-2V, F4-2B. Typically 3 seconds for models F4-4V, F4-4B. 200 msec response to flash flare. |
| Adjustable Time Delay | Up to 30 seconds |
| Sensitivity Ranges | 1ft ² (0.1m ²) n-heptane pan fire from 50 ft. (15m) for models F4-2V, F4-2B 1ft ² (0.1m ²) n-heptane pan fire from 66 ft. (20m) for models F4-4V, F4-4B |

Fields of View Horizontal 100°, Vertical 95°

Built-In-Test (BIT) Automatic (and Manual)

UV Sensor F4-UV, F4-VB

Spectral Response UV:0.185 – 0.260µm

| Detection Range (at highest Sensitivity Setting for 1ft ² (0.1m ²) pan fire) | Fuel | ft. / m | Fuel | ft. / m |
|---|-------------|----------------|---------------|----------------|
| | Gasoline | 50 / 15 | Methanol | 37 / 11 |
| | n-Heptane | 50 / 15 | Methane * | 40 / 12 |
| | JP5 | 37 / 11 | LPG * | 40 / 12 |
| | Kerosene | 37 / 11 | Paper | 20 / 6 |
| | Diesel Fuel | 37 / 11 | Polypropylene | 18 / 5 |
| | Ethanol 95% | 37 / 11 | Hydrogen* | 33 / 10 |
| | IPA | 37 / 11 | Silane* | 22 / 7 |

* 20" (0.5m) high, 8" (0.2m) width plume fire

Response Time Typically 3 seconds
200 msec response to flash flare

Adjustable Time Delay Up to 30 seconds

Sensitivity Ranges 1ft² (0.1m²) n-heptane pan fire from 50 ft. (15m)

Fields of View Horizontal 100°, Vertical 95°

Built-In-Test (BIT) Automatic (and Manual)

Fast UV/IR F4-UF

Spectral Response UV:0.185 – 0.260µm IR:2.5 - 3.0µm

| Detection Range (at highest Sensitivity Setting for 1ft ² (0.1m ²) pan fire) | Fuel | ft. / m | Fuel | ft. / m |
|---|--------------|----------------|----------------------------|----------------|
| | n-Heptane | 65 / 20 | Kerosene | 42 / 14 |
| | Gasoline | 65 / 20 | Ethanol 95% | 23 / 7 |
| | Diesel Fuel | 40 / 13.5 | Methanol | 26 / 8 |
| | JP5 | 42 / 14 | IPA (Isopropyl Alcohol) | 43 / 13 |
| | Methane* | 16 / 5 | Polypropylene Pellets | 16 / 5 |
| | LPG* | 16 / 5 | Ammonia* | 16 / 5 |
| | Hydrogen* | 23 / 7 | Silane* | 20 / 6 |
| | Office Paper | 16 / 5 | | |

* 20" (0.5m) high, 8" (0.2m) width plume fire

| | |
|------------------------------|--|
| Response Time | Typically 3 seconds. High speed 20 msec response to Flash fire |
| Adjustable Time Delay | Up to 30 seconds |
| Sensitivity Ranges | 1 ft ² (0.1m ²) n-heptane pan fire from 65 ft. (20 m) |
| Fields of View | Horizontal 100°, Vertical 90° |
| Built-In-Test (BIT) | Automatic (only) |

A.2 Electrical Specifications

Operating Voltage: 18-32VDC

Power Consumption: Table 24

Table 24: Electrical Specifications

| Operating Voltage | Status | All Outputs | Without 0-20mA |
|-----------------------------------|-----------------------|-------------|----------------|
| Power Consumption (Max. 24VDC) | Normal | 1.61W | 1.56W |
| | Normal when Heater On | 2.28W | 2.16W |
| | Alarm | 2.64W | 2.28W |
| | Alarm when Heater On | 3.24W | 2.88W |
| Maximum Current (Max. 24VDC) | Normal | 70mA | 65mA |
| | Normal when Heater On | 95mA | 90mA |
| | Alarm | 110mA | 95mA |
| | Alarm when Heater On | 135mA | 120mA |
| Power Consumption (Max. 18-32VDC) | Normal | 1.95W | 1.85W |
| | Normal when Heater On | 2.56W | 2.45W |
| | Alarm | 3.04W | 2.56W |
| | Alarm when Heater On | 3.68W | 3.2W |
| Maximum Current (18-32VDC) | Normal | 90mA | 85mA |
| | Normal when Heater On | 105mA | 100mA |
| | Alarm | 130mA | 115mA |
| | Alarm when Heater On | 160mA | 145mA |

Electrical Input Protection

The input circuit is protected against voltage-reversed polarity, voltage transients, surges and spikes according to:

MIL-STD-1275B

A.3 Outputs

Electrical Interface

There are five output-wiring options. These options must be defined at the factory per the customer order and cannot be changed at the customer facility.

See *General Instructions for Electrical Wiring* for the wiring/terminal diagram for each option.

Unless otherwise specified, the default is Option 1. The wiring arrangement is identified on the detector by the part number (see Model and Types).

- **Option 1:** Power, RS-485, 0-20mA (Sink), Fault I Relay (N.C), Alarm Relay, (N.O) (see Figure 7).
- **Option 2:** Power, RS-485, 0-20mA (Source) and HART protocol, Analog Output, Fault Relay (N.O), Alarm Relay, (N.O), (N.C).
- **Option 3:** Power, RS-485, 0-20mA (Source) and HART protocol, Analog Output, Fault Relay (N.O), Alarm Relay (N.O, N.C).
- **Option 4:** Power, RS-485, Analog Output, Fault Relay (N.C), Auxiliary Relay (N.O), Alarm Relay, (N.O).
- **Option 5:** Power, RS-485, Analog Output, Fault Relay (N.O), Auxiliary Relay (N.O), Alarm Relay, (N.O).

Electrical Outputs

- **Dry Contact Relays**

Table 25: Contact Ratings

| Relay Name | Type | Normal Position | Maximum Ratings |
|------------------------------|------|-----------------|-----------------|
| Alarm | SPDT | N.O., N.C. | 2A at 30 VDC |
| Auxiliary | SPST | N.O. | 2A at 30 VDC |
| Fault (see Notes 1 and 2) | SPST | N.C. or N.O | 2A at 30 VDC |

Notes:

1. The Fault relay (in wiring options 1, 2, 4) is normally energized closed during normal operation of the detector. The relay is de-energized open if a fault condition or low voltage situation occurs.
2. In wiring options 3, 5 the relay is normally energized open during normal operation of the detector. The relay is de-energized close contact if a fault condition or low voltage situation occurs.

- **0-20mA Current Output:** The 0-20mA can be Sink or Source according to the wiring option source (see *General Instructions for Electrical Wiring*). The maximum permitted load resistance is 600Ω.

Table 26: 20 mA Current Output

| State | Output |
|-----------|-----------|
| Fault | 0 +1 mA |
| BIT Fault | 2 mA ±10% |
| Normal | 4 mA ±10% |
| IR* | 8 mA ±5% |
| UV* | 12 mA ±5% |
| Warning | 16 mA ±5% |
| Alarm | 20 mA ±5% |

*Applies to only to models with those sensor types.

- **Analog Output**
The Analog Output is used for fast detection signal 20msec. It provides 0 V at Normal and 5 V at Alarm.
- **HART Protocol**
The HART protocol is a digital communication signal at a low level on top of the 0-20mA. This is a bi-directional field communication protocol used to communicate between intelligent field instruments and the host system. HART is available in wiring options 2 and 3.
Through the HART protocol the detector can:
 - Display set-up
 - Reconfigure the set-up
 - Display detector status and definition
 - Perform detector diagnostics
 - Troubleshoot
 For more details refer to *HART Manual 087-0057*.
- **Communication Network:** The detector is equipped with an RS-485 communication link that can be used in installations with computerized controllers. The communications protocol is Modbus compatible.
 - This protocol is a standard and widely used.
 - It enables continuous communication between a standard Modbus controller (Master device) and a serial Network of up to 247 detectors.

- Heated Optics**
- The front window can be heated to improve performance in icing, condensation and snow conditions. The heater increases the temperature of the optical surface by 5-8°F (3-5°C) above the ambient temperature. The heated optics can be configured in three ways:
- **Off:** The optics are not heated
 - **On:** The optics are heated continuously
 - **Auto:** Operated only when the change of temperature requires the heating. (default)
- In **Auto** mode the start heating temperature can be defined between 32°F - 122°F (0°C - 50°C). The detector stops heating the window when the temperature is 27°F (15°C) above the start temperature.

A.4 Mechanical Specifications

- | | |
|--|---|
| Enclosure | <ul style="list-style-type: none"> • Stainless Steel 316 or Aluminum, heavy duty copper free (less than-1%), red epoxy enamel finish |
| Water and Dust Tight | <ul style="list-style-type: none"> • NEMA 250 type 6p. • IP 66 and IP 67 per EN 60529 |
| Electronic Modules | <ul style="list-style-type: none"> • Conformal coated |
| Electrical Connection (two entries) | <ul style="list-style-type: none"> • ¾" - 14NPT conduit <i>or</i> • M25 x 1.5 |
| Dimensions | <ul style="list-style-type: none"> • 4" x 4.6" x 6.18" (101.6 x 117 x 157 mm) |
| Weight | <ul style="list-style-type: none"> • Stainless Steel: 6.1 lb. (2.8 kg) • Aluminum: 2.8 lb. (1.3 kg) |

A.5 Environmental Specifications

The MultiFlame FV-40 Series is designed to withstand harsh environmental conditions.

- | | |
|-------------------------|---|
| High Temperature | <ul style="list-style-type: none"> • Designed to meet MIL-STD-810C, method 501.1 procedure II • Operating temperature: +167°F (+75 °C) • Storage temperature: +185 °F (+85 °C) |
| Low Temperature | <ul style="list-style-type: none"> • Designed to meet MIL-STD-810C, method 502.1, procedure I • Operating temperature: -57°F (-50°C) • Storage temperature: -65°F (-55°C) |
| Humidity | <ul style="list-style-type: none"> • Designed to meet MIL-STD-810C, method 507.1, procedure IV • Relative humidity of up to 95% for the operational temperature range |

- Salt Fog**
 - Designed to meet MIL-STD-810C, method 509.1, procedure I
 - Exposure to a 5% Salt Solution Fog for 48 hours
- Dust**
 - Designed to meet MIL-STD-810C, method 510.1, procedure I
 - Exposure to a dust concentration of 0.3 frames/cubic ft. at a velocity of 1750 fpm, for 12 hours
- Vibration**
 - Designed to meet MIL-STD-810C, method 514.2, procedure VIII
 - Vibration at an acceleration of 1.1g within the frequency range of 5-30 Hz, and an acceleration of 3g within the frequency range of 30-500 Hz
- Mechanical Shock**
 - Designed to meet MIL-STD-810C, method 516.2, procedure I
 - Mechanical Shock of 30g half-sine wave, for 11 msec
- Electromagnetic Compatibility (EMC)**
 - Table 27

Table 27: Electromagnetic Compatibility (EMC)

| | Test Standard | Level Per |
|--|----------------------|------------------|
| Electrostatic Discharge ESD | IEC 61000-4-2 | IEC 61326-3 |
| Radiated EM Field | IEC 61000-4-3 | IEC 61326-3 |
| Electrical Fast Transients | IEC 61000-4-4 | IEC 61326-3 |
| Surge | IEC 61000-4-5 | IEC 61326-3 |
| Conducted Disturbances | IEC 61000-4-6 | IEC 61326-3 |
| Power Freq. Magnetic Field | IEC 61000-4-8 | IEC 61326-3 |
| Radiated Emission | IEC 61000-6-3 | EN 55022 |
| Conducted Emission | IEC 61000-6-3 | EN 55022 |
| Immunity to Main Supply Voltage Variations | MIL-STD-1275B | |

To fully comply with EMC directive and protect against interference caused by RFI and EMI, the cable to the detector must be shielded and the detector must be grounded. The shield should be grounded at the detector end.

B Wiring Instructions

Failure to review and understand these instructions could lead to improper wiring which could create an improperly functioning detector and may cause serious injury or death.

➤ In this appendix...

General Instructions for Electrical Wiring

Typical Wiring Configurations

B.1 General Instructions for Electrical Wiring

Follow the instructions detailed in this section for determining the correct wire gauge to be used for the installation.

Use Table 28 to determine the required wire gauge /size for general wiring, such as relay wiring. Calculate the permitted voltage drop with respect to load current, wire gauge and length of wires.

Table 28: Maximum DC resistance at 68°F (20°C) for copper wire

| AWG # | mm ² | Ohm per 100 ft. | Ohm per 100 m |
|-------|-----------------|-----------------|---------------|
| 26 | 0.12 - 0.15 | 4.32 | 14.15 |
| 24 | 0.16 - 0.24 | 3.42 | 11.22 |
| 22 | 0.30 - 0.38 | 1.71 | 5.60 |
| 20 | 0.51 - 0.61 | 1.07 | 3.50 |
| 18 | 0.81 - 0.96 | 0.67 | 2.20 |
| 16 | 1.22 - 1.43 | 0.43 | 1.40 |
| 14 | 1.94 - 2.28 | 0.27 | 0.88 |
| 12 | 3.09 - 3.40 | 0.17 | 0.55 |
| 10 | 4.56 - 6.64 | 0.11 | 0.35 |

Use Table 29 to select wire gauge for power supply wires. DO NOT connect any circuit or load to detectors' supply inputs.

- Select **Number of detectors** connected in one circuit.
- Select wiring **Length** per your installation requirements.
- Refer to **Power Supply Range** for voltage extreme applied.

Table 29: Wiring length in feet (meter)

| Number of Detectors | Recommended Wire Diameter (AWG) | | | | | Power Supply Range (VDC) |
|---|---------------------------------|--------------|--------------|--------------|--------------|--------------------------|
| | 18 | 16 | 14 | - | - | |
| 24 | 18 | 16 | 14 | - | - | 22-32 |
| 20 | 18 | 16 | 14 | - | - | 22-32 |
| 16 | 20 | 18 | 16 | 14 | - | 22-32 |
| 12 | 20 | 18 | 16 | 14 | - | 20-32 |
| 8 | 20 | 18 | 16 | 14 | - | 20-32 |
| 4 and less | 20 | 18 | 16 | 16 | 14 | 20-32 |
| Ft (m) | 164 (50) | 328 (100) | 492 (150) | 656 (200) | 820 (240) | |
| Max. Length from Power Supply to Last Detector | | | | | | |

Calculation Formula

Use the following formula to calculate minimum wire gauge per wire length between the power supply (controller) and the detector, considering the number of detectors on the same power line, where:

L = Actual wire length between the detector and the power supply.

N = Number of detectors per loop.

R = Resistance of wire per 100 m (see Table 28).

V = Voltage drop on the wire.

Calculate the voltage drop on the wire as follows:

$$V = \frac{2L \times R}{100} \times N \times 0.2A$$

20+V = Minimum required voltage of the power supply

0.2A is the maximum power consumption of the detector

For example,

If N=1 (1 detector in loop)

$$L=1000m$$

Wire size = 1.35mm² (see Table 29, the resistance per 100m for 1.35mm² is 1.4Ω)

You calculate the voltage drop in the wire as follows:

$$\frac{2 \times 1000 \times 1.4\Omega}{100} \times 1 \times 0.2A = 5.6V$$

The minimum voltage of the power supply should be 20V + 5.6V = 25.6V

B.2 Typical Wiring Configurations

This section describes examples of typical wiring configurations.

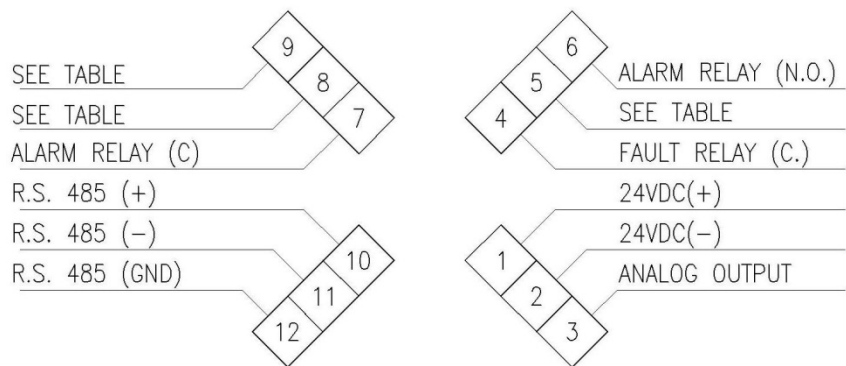

Figure 6: Wiring Terminals

Table 30: Wiring Connections

| Wiring Option | Terminals | | | |
|---------------|---------------|-------------------|-----------------------|----------------------|
| | 3 | 5 | 8 | 9 |
| 1 | Analog Output | Fault Relay (N.C) | 0-20mA (Sink) | 0-20mA (Sink) |
| 2 | Analog Output | Fault Relay (N.C) | Alarm Relay (N.C) | 0-20mA Source |
| 3 | Analog Output | Fault Relay (N.O) | Alarm Relay (N.C) | 0-20mA Source |
| 4 | Analog Output | Fault Relay (N.C) | Auxiliary Relay (N.O) | Auxiliary Relay N.O. |
| 5 | Analog Output | Fault Relay (N.O) | Auxiliary Relay (N.O) | Auxiliary Relay N.O. |

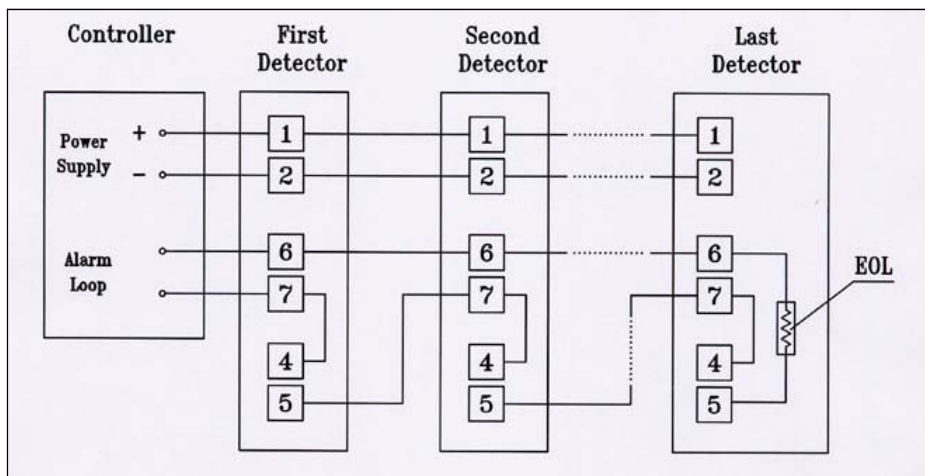

Figure 7: Typical Wiring for 4 Wire Controllers (Using Option 1 or 2 Wiring)

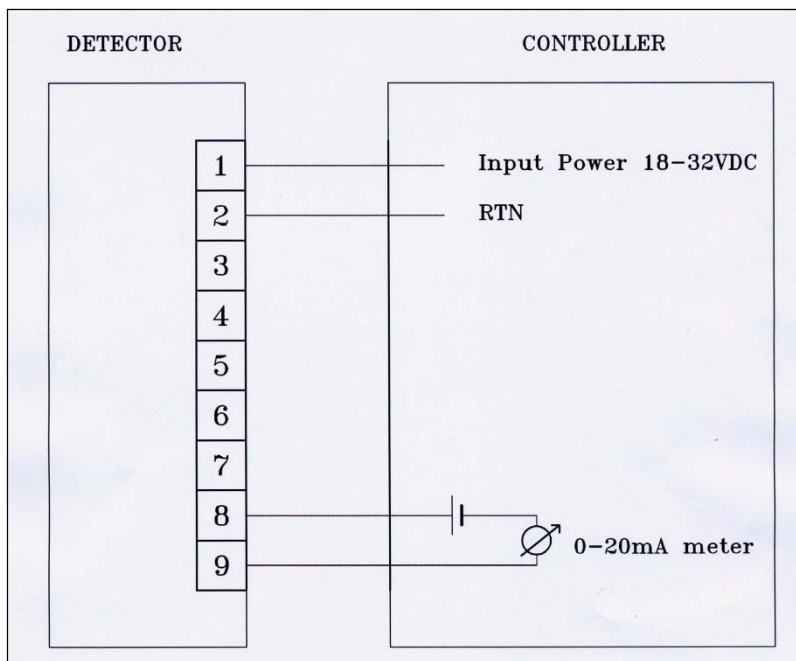

Figure 8: 0-20mA Wiring Option 1 (Sink 4-Wire) - Default

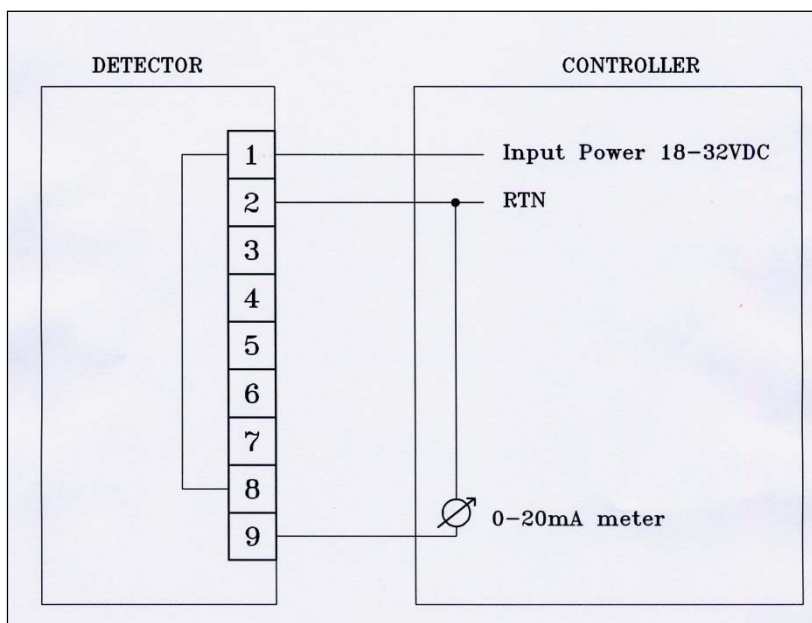

Figure 9: 0-20mA Wiring Option 1 (Converted to Source 3-Wire)

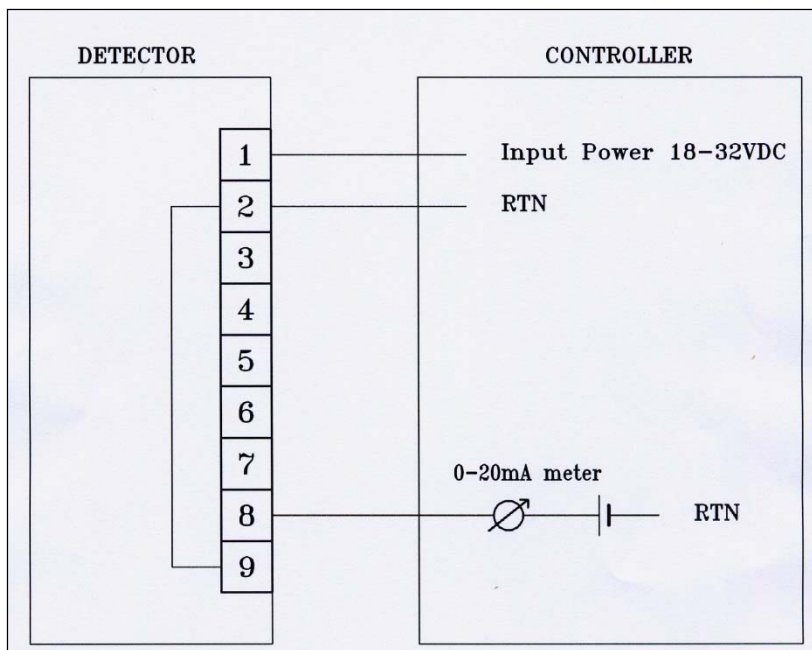

Figure 10: 0-20mA Wiring Option 1 (Non-isolated Sink 3-Wire)

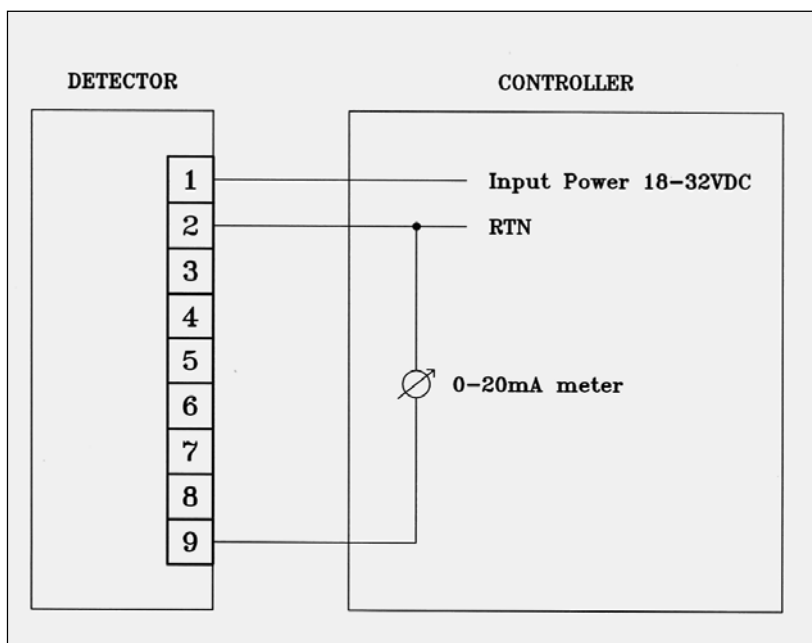

Figure 11: 0-20mA Wiring Option 2 and 3 (Source 3-Wire available with the HART Protocol)

Note: There are no 0-20mA outputs in wiring options 4 and 5.

C RS-485 Communication Network

➤ In this appendix...

RS-485 Overview

C.1 RS-485 Overview

By using the RS-485 network capability of the UV/IR detector and additional software, it is possible to connect up to 32 detectors in an addressable system with four (4) wires only (2 for power and 2 for communication). Using repeaters, the number of detectors can be much larger (32 detectors for each repeater) up to 247 on the same four (4) wires. When using the RS-485 network, it is possible to read each detector status (FAULT, WARNING, and ALARM) and to initiate a BIT to each detector individually.

For more details, consult Scott Safety.

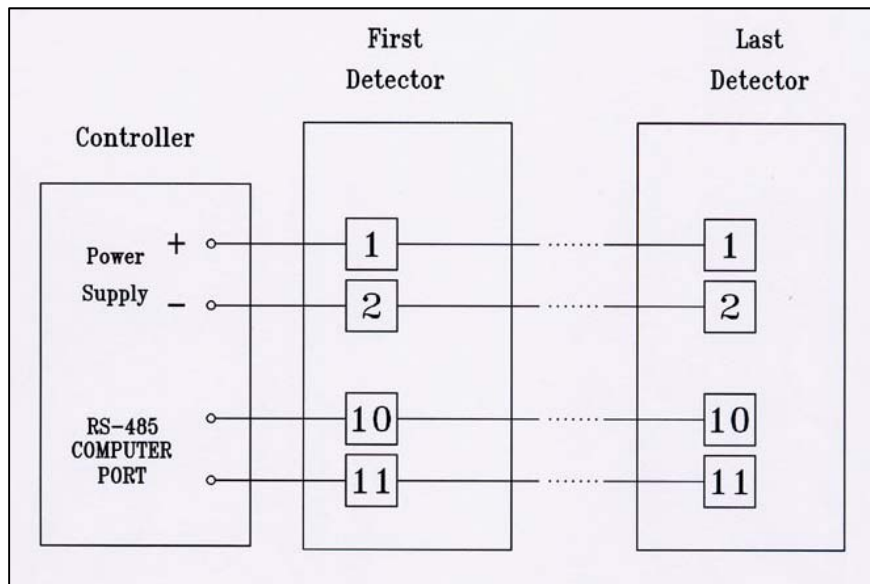

Figure 12: RS-485 Networking

D Accessories

If any accessories are used with the detector, follow these installation instructions. Failure to do so could lead to improperly installed accessories which could lead to serious injury or death.

➤ **In this appendix...**

Long Range Flame Simulator

Tilt Mount

Duct Mount

Weather Protection

Laser Detection Coverage Pointer

Air Shield

This appendix describes the accessories that can help you maximize fire detection with the MultiFlame UV/IR flame detector:

D.1 Long Range Flame Simulators

The MultiFlame Long Range Flame Simulator 380114-1 (IR3), 380114-2 (UV/IR), 380114-3 (IR) and 380114-4 (Multi IR) are designed specifically for use with MultiFlame flame detectors. Depending on the model of Flame Detector in your installation, choose the proper Flame Simulator for your application. The Flame Simulator emits radiation in a unique sequential pattern corresponding to and recognizable by the detector as fire. This allows the detectors to be tested under simulated fire conditions without the associated risks of an open flame.



Figure 13: Flame Simulator 380114-1

D.1.1 Unpacking

Verify that you have received the following contents:

- Delivery form
- Fire Simulator with integral batteries
- Battery charger
- User Manual and Tool keys
- Storage case

D.1.2 Operating Instructions



Warning: Do not open the Fire Simulator to charge the batteries or for any other reason in a hazardous area. **Failure to do so may result in serious injury or death.**

Caution: The following test simulates a real fire condition and may activate the extinguishing system or other alarms. If this is not desired, disconnect/inhibit them before the test and reconnect after the simulation.

➤ **To simulate a fire:**

- A. Verify you are at the correct distance from the detector according to the type of detector and the detector sensitivity. Aim the Flame Simulator at the Flame Detector using the aiming guides at the 12 o'clock position of the face of the flame detector you wish to test.
- B. Using the mechanical sight, aim the flame simulator toward the center of the detector.
- C. Push the activate button, and then use the laser spot for fine adjustment toward the center of the detector.
- D. Keep the simulator aimed at the detector for up to 50 seconds, until you trigger an alarm.
- E. Wait 20 seconds before repeating the test.

D.1.3 Range

Table 31: Sensitivity Ranges

| Sensitivity | Detection Range (ft. / m) | Standard Test Range (ft. / m) | Extended Test Range (ft. / m) |
|-------------|---------------------------|-------------------------------|-------------------------------|
| 1 (Low) | 50 / 15 | 3.8 / 1.2 | 7 / 2.2 |
| 2 | 100 / 30 | 7 / 2.2 | 14.5 / 4.5 |
| 3 | 150 / 45 | 10 / 3.2 | 22 / 7 |
| 4 (High) | 215 / 65 | 14.5 / 4.5 | 29 / 9 |

Notes:

- The minimum distance from the detector is 30 inches (75 cm).
At extreme temperatures, there is a 15% maximum reduction in the range.

Important: Keep the Fire Simulator in a safe place when not in use.

D.1.4 Charging the Battery

Failure to use properly charged batteries could lead to serious injury or death.

The Fire Simulator uses lithium-ion batteries as a rechargeable power source. When the batteries are fully charged, the simulator operates for at least 1000 times without recharging. The simulator will not operate when the voltage from the batteries is lower than the required operational level.

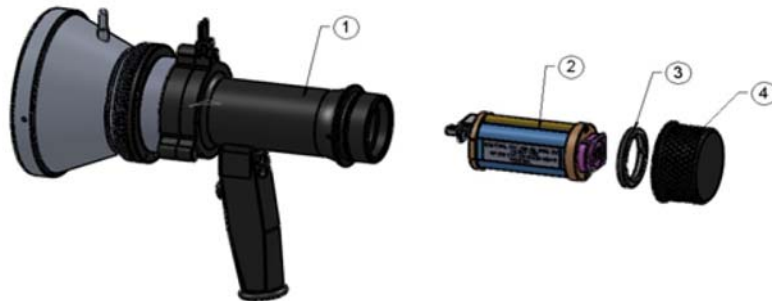

| | |
|---|--------------|
| 1 | Simulator |
| 2 | Battery Pack |
| 3 | Locking Disc |
| 4 | Back Cover |

Figure 14: Flame Simulator Battery Replacement

➤ **To charge the battery:**

- Place the Fire Simulator on a table in a safe area, not exceeding 104°F/40°C.
- Release the locking screw.
- Unscrew the battery back cover (Item 4) counter clockwise.
- Unscrew the locking disc (Item 3) clockwise.
- Pull out the battery from the Flame Simulator.
- Connect the battery charger. Verify that the charger is the one supplied with the flame simulator.
- Charge for a maximum of 2–3 hours.
- Disconnect the charger.
- Insert the battery into the flame simulator.

- J. Screw on the locking disc (Item 3).
- K. Screw on the back cover (Item 4).
- L. Lock the back cover with the locking screw.

D.1.5 Technical Specifications

- General**
 - Temperature Range: -4°F to +122°F / -20°C to +50°C
 - Vibration Protection: 1g (10-50Hz)
- Electrical**
 - Power: 14.8V (4 X 3.7V rechargeable lithium-ion battery)
 - Max. Current: 4A
 - Battery Capacity: 2.2AH
 - Charging Time: 2A at 2hr
- Physical**
 - Dimensions: 230 x 185 x 136 mm
 - Weight: 5.5lb/2.5kg
 - Enclosure: aluminum, heavy duty copper free, black zinc coating
 - Explosion proof enclosure:
- ATEX & IECEx**
 - Ex II 2 G D
 - Ex db ib op is IIB +H₂ T5 Gb
 - Ex ib op is tb IIIC T135°C Db
 - -4°F to +122°F / -20°C to +50°C
- EMI Compatibility [see table 32]

Table 32: EMI Compatibility

| Immunity Tests | | |
|--|----------------|---|
| Title | Basic Standard | Level to be tested |
| Electrostatic Discharge (ESD) | IEC 61000-4-2 | 6kV/8kV contact/air |
| Radiated Electromagnetic Field | IEC 61000-4-3 | 20V/m (80MHz-1GHz) 10V/m (1.4-2GHz) 3V/m (2.0-2.7GHz) |
| Conducted Disturbances | IEC 61000-4-6 | 10Vrms (150kHz-80MHz) |
| Immunity to Main Supply Voltage Variations | MIL-STD-1275B | |

| Emission Tests | | | |
|-------------------|----------------|---|--------------------------|
| Title | Basic Standard | Level to be Tested | Class |
| Radiated Emission | IEC 61000-6-3 | 40dbuv/m (30-230MHz), 47dbuv/m (230MHz-1GHz) | Like Class B of EN 55022 |

D.2 Tilt Mount

The Tilt mount P/N 093-0543 provides accurate directional selection for optimum area coverage.

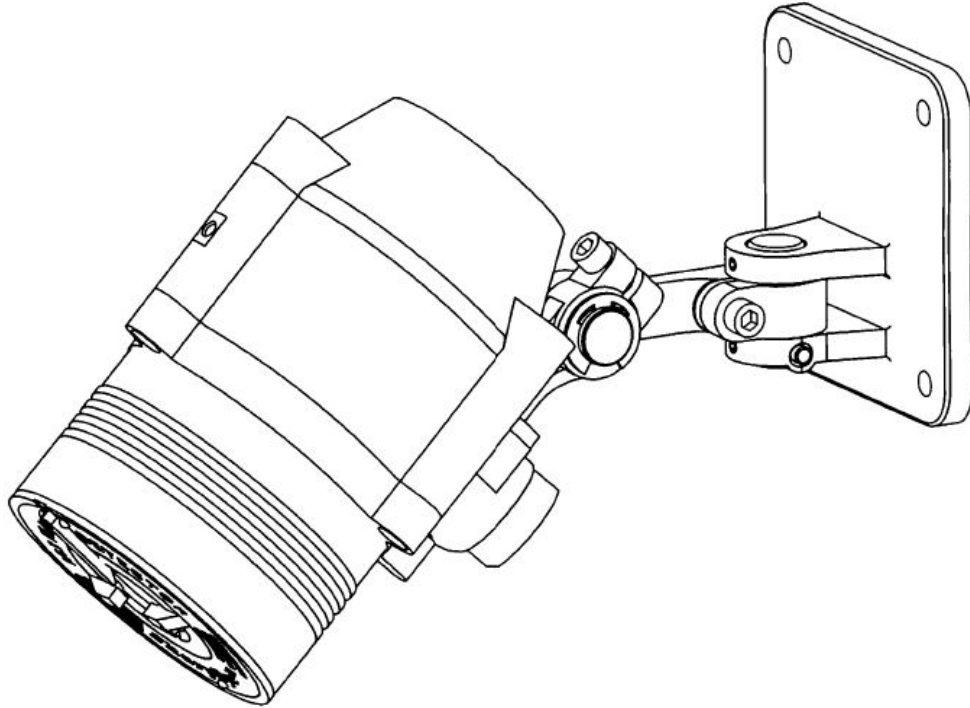

Figure 15: Tilt Mount

D.3 Duct Mount

The Duct Mount P/N 093-0612 enables flame detection in areas where high temperatures exist or where the detector cannot be installed inside the area. It comprises a special duct mount arrangement with a specific optical window to allow installation in high temperature duct applications. The mount can be used with all Scott Safety FV-40 Series flame detectors.

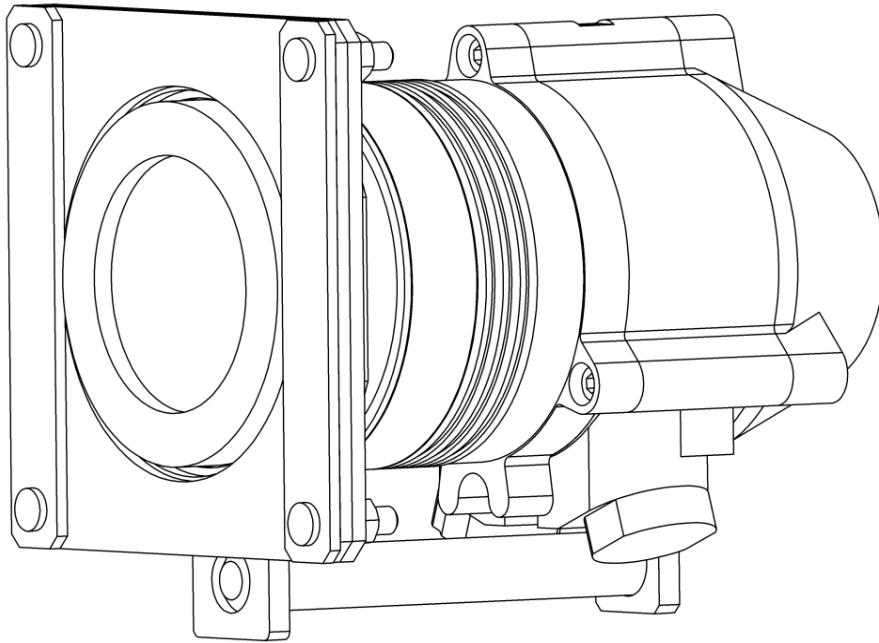

Figure 16: Duct Mount

D.4 Weather Protection

The weather protector P/N 093-0552 protects the detector from different weather conditions, such as snow and rain.

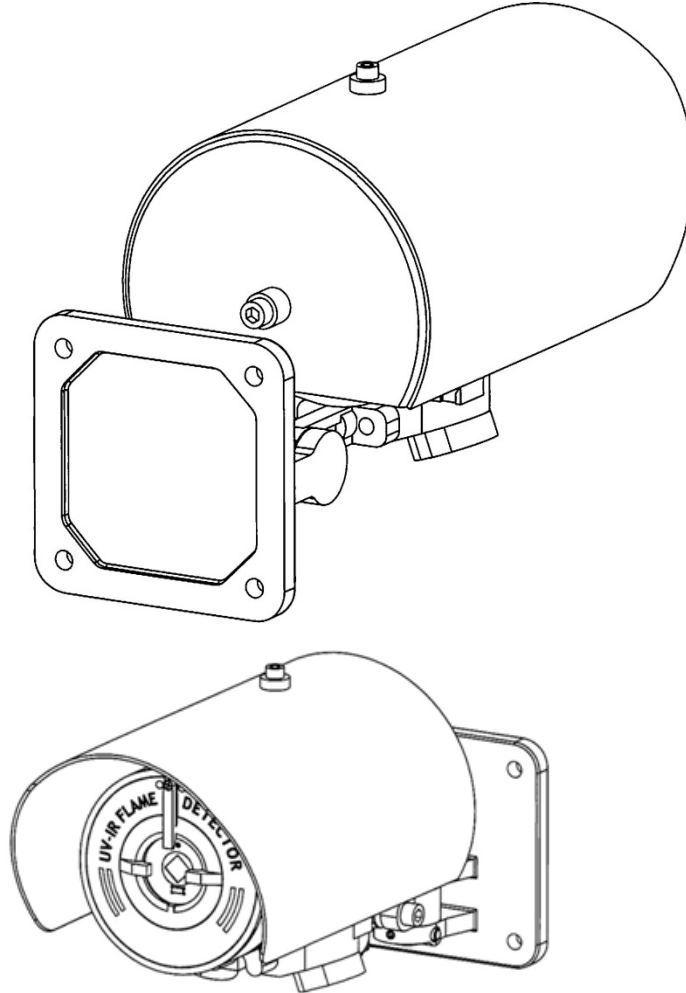

Figure 17: Weather Protection

D.5 Laser Detection Coverage Pointer

The Laser Detection Coverage Pointer P/N 093-0549 evaluates detector coverage on-site. The device is an add-on accessory that enables designers and installers to optimize detector location and assess the actual coverage of installed detectors.

The device is universal and can be used with all FV-40 MultiFlame Optical Flame Detectors.

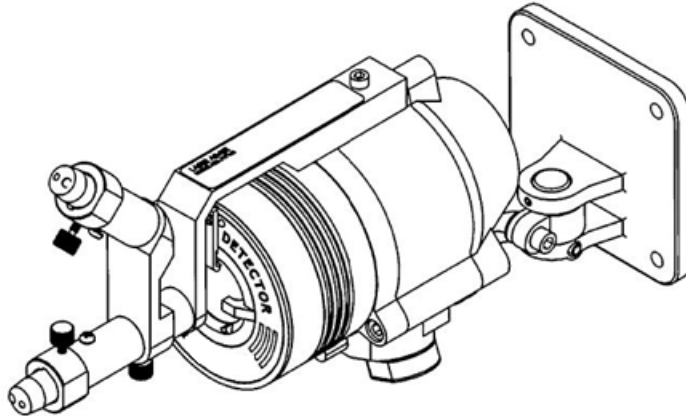

Figure 18: Laser Detection Coverage Pointer

D.6 Air Shield

The Air Shield P/N 093-0548 enables you to install the detector in dirty areas and using compressed air, keep the window clean. This prevents the accumulation of dirt on the window and enables the detector to continue to operate under harsh conditions.

When the air shield is fitted on the detector, it reduces the cone of vision of the detector by $\pm 5^\circ$ in each direction.

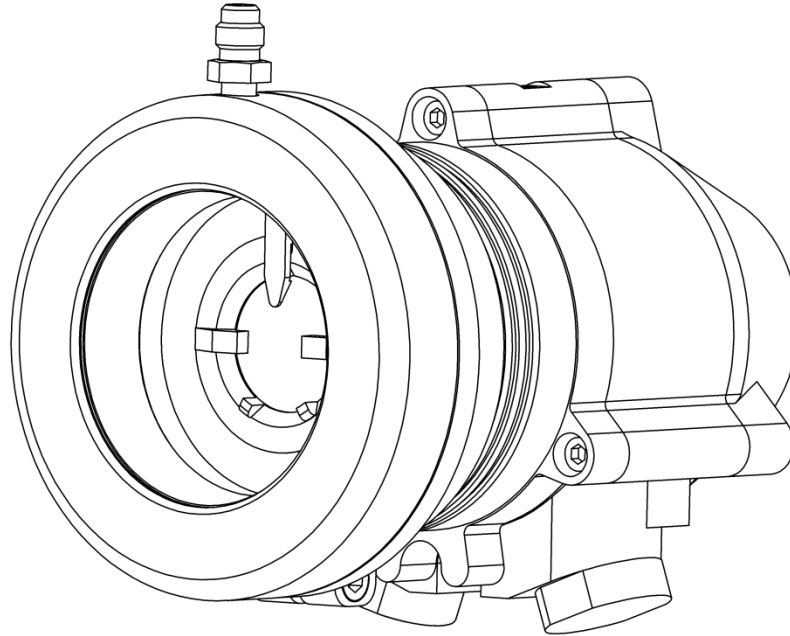

Figure 19: Air Shield

E SIL-2 Features

➤ In this appendix...

FV-40 Series Flame Detector

E.1 FV-40 Series Flame Detector

This appendix details the special conditions to comply with the requirements of EN 61508 for SIL 2. (Approval pending for some models).

The FV-40 Series Flame Detector can only be used in low or high demand mode applications, see IEC 61508.4, Chapter 3.5.12.

E.1.1 Safety Relevant Parameters

Perform the following functional checks of the detector:

- **Alternative 1:** Functional check of the detector every 180 days:
 - **HFT:** 0
 - **PFD:** 3.0×10^{-4} ($\approx 3\%$ of SIL-2) if only Alarm Relay is used for alerting.
 - **PFD:** 3.2×10^{-4} ($\approx 3.2\%$ of SIL-2) if 0-20mA – interface is used as alarm.
 - **PFH:** 1.5×10^{-7} 1/h ($\approx 14.9\%$ of SIL-2) for 0-20mA application.
 - **SFF:** 95% fulfills the conditions of EN 61508 for SIL2
- **Alternative 2:** Functional check of the detector every 365 days:
 - **HFT:** 0
 - **PFD:** 4.5×10^{-4} ($\approx 4.5\%$ of SIL-2) if only Alarm Relay is used for alerting.
 - **PFD:** 4.9×10^{-4} ($\approx 4.9\%$ of SIL-2) if 0-20mA – interface is used signal current as alarm.
 - **PFH:** 1.5×10^{-7} 1/h ($\approx 14.9\%$ of SIL-2) for 0-20mA application.
 - **SFF:** 95% fulfills the conditions of EN 61508 for SIL2

E.1.2 Guidelines for Configuring, Installing, Operating and Service

The alert conditions according to SIL 2 can be implemented by an:

- Alert signal via 20mA current loop
- or
- Alert signal via alarm relay and the fault relay

E.1.2.1 Conditions for Safe Operating

- A. The flame detector shall consist only of the approved hardware and software modules.
- B. The 24V power supply must fulfill the requirements for PELV / SELV of EN 60950.
- C. The automatic BIT (Built-In-Test) must be activated.
- D. The set-up parameters must be verified (as described in *Using the 0-20mA Interface for Alerting*, point 0 and in *Using the Alarm Relay Contact for Alerting*, point 0) and the function of the FV-40 Flame Detector (flame detection, function of the 0-20mA interface, relay functions) must be checked completely.

E.1.2.2 Using the 0-20mA Interface for Alerting

The following parameters shall be set:

- AUTOMATIC BIT test = on
- Connected to 0-20mA Terminals

The following allowed output current must be supervised with an accuracy of $\pm 5\%$:

- Normal State = 4mA
- Warning State = 16mA
- Alarm State = 20mA

The output current must be supervised regarding the over-and under run of the 0-20mA.

The 0-20mA can be used as low and high demand mode.

E.1.2.3 Using the Alarm Relay Contact for Alerting

The following parameters shall be set:

- AUTOMATIC BIT Test = on
- Connected to N.C contact of Alarm Relay Terminals
- Connected to Fault Relay Terminals

The relay contacts ("alarm" – and "faulty relay") must be protected with a fuse rated at 0.6 of the nominal specified relay contact current.

The maximum contact rating that is allowed per SIL-2 is 30VDC.

It is to be considered that the contact of the Alarm Relay opens if there is a fire alarm.

During the forwarding and evaluation of the alarm it must be noted that the relay contact opens.

The alarm relay can be used as low demand only.

E.1.2.4 Other

The complete function of the flame detector (flame detection, function of the 0-20mA interface, the relays) must be examined at least every six or twelve months (see *Safety Relevant Parameters*, when the flame detector must be switched OFF and ON.

The window of the sensor must be examined at appropriate time intervals for partial contamination.

The HART and the RS 485 interfaces must not be used for the transmission of the safety-related data.

F F Online FV-40 Configurator Part Code

When ordering online, the product configuration detail is included in the product part number (and on the sales order confirmation) and takes the form: F4-XX-X-X-X-XX-X-X-X-X, where XX-X-X-X-XX-X-X-X-X defines the model according to the Table 33 and Table 34.

To modify the default or pre-ordered configuration and perform maintenance tasks, please refer to the *HART Protocol 087-0057*, WinHost for FV-40 Flame Detectors *087-0058* or *087-0055*.

The Part Numbers are defined as:

Table 33: Part Number Configuration (Online Ordering)

| Series | Model | | Wiring | | Approvals/ Temp | | Housing | |
|--------|-------|-------------------------------|--------|--|--------------------|---|---------|-----------------|
| | | | | | | | | |
| F4- | IR | Single IR | 1- | RS485, 4-20mA as Sink, Fault relay NC, no Accessory relay, Alarm relay NO | F- | Factory Mutual, ¾ English thread and 75C | S- | Stainless Steel |
| | MM- | Multi IR | 2- | RS485, 4-20mA as Source, Fault relay NC, no Accessory relay, Alarm relay NO/NC | A- | Atex, M25 Thread, 75C | A- | Aluminum |
| | I3- | Triple Ir | 3- | RS485, 4-20mA as Source, Fault relay No, no Accessory relay, Alarm Relay NO/NC | C- | Atex, ¾ English Thread, 75C | | |
| | UV- | UV | 4- | RS485, no 4-20mA, Fault relay NC, Accessory relay No, Alarm relay NO | D- | Factory Mutual, M25 Metric Thread and 75C | | |
| | VB- | UV-B | 5- | RS485, no 4-20mA, Fault relay NO, Accessory relay NO, Alarm relay NO | | | | |
| | 2V- | UV/IR 2.5um wavelength | | | | | | |
| | 2B- | UV/IRB 2.5um wavelength | | | | | | |

| Series | Model | | Wiring | | Approvals/ Temp | | Housing | |
|--------|-------|-----------------------------|--------|--|--------------------|--|---------|--|
| | 4V- | UV/IR 4um wavelength | | | | | | |
| | 4B- | UV/IRB 4um wavelength | | | | | | |
| | UF- | Ultra Fast UV/IR | | | | | | |

Note: Highlighted area designate default settings.

Table 34: Configurable Options (Online Ordering)

| Alarm | | Heating | | Built in Test | | | Sensitivity | | |
|-------|------------|---------|---|---------------|--|---|--|------------------------|-----------|
| | | | Function | | Alarm/Automatic BIT | | Accessory relay | | |
| 00- | 0 Seconds | N- | None | 0- | none | 0- | none | 5 | 5m/15ft |
| 0A- | Anti Flare | O- | On | 1- | Alarm latching enabled | 1- | Activate accessory relay on Warning | 1 | 15m/50ft |
| 03- | 3 Seconds | A- | Automatic on temperature change. | 2- | Enable Automatic BIT | 2- | Activate Accessory Relay on successful manual BIT | 3 | 30m/100ft |
| 05- | 5 Seconds | | 20C is default. Need to enter value if other than 20 deg C. | 3- | Alarm latching enabled, | 3- | Activate accessory relay on Warning | 4 | 45m/150ft |
| 10- | 10 Seconds | | | | Enable Automatic BIT | | Activate Accessory Relay on successful manual BIT | 6 | 65m/215ft |
| 15- | 15 Seconds | | | | 4- | Activate Alarm on successful manual BIT | 4- | Accessory relay as EOL | |
| | | | | 5- | Activate Alarm on successful manual BIT Alarm latching enabled, | 5- | Accessory relay as EOL Activate accessory relay on Warning | | |
| | | | | 6- | Activate Alarm on successful manual BIT Enable Automatic BIT | 6- | Activate Accessory Relay on successful manual BIT Accessory relay as EOL | | |
| | | | | 7- | Activate Alarm on successful manual BIT Enable Automatic BIT Alarm latching enabled, | 7- | Activate accessory relay on Warning Activate Accessory Relay on successful manual BIT Accessory relay as EOL | | |

Highlighted area designates default settings

Note: Wiring Option 1- is default. The mA 'Sink' output can be altered to 'Source' type, with a link between terminals 1 and 8. No other wiring options can be changed on site.

Note: Check your specific part numbers against the information in *Checking the Product Type*.

Note: The Tilt Mount is automatically included in the order when the product is ordered through the online configurator.



Thank you for reading this data sheet.

For pricing or for further information, please contact us at our UK Office, using the details below.



UK Office

Keison Products,

P.O. Box 2124, Chelmsford, Essex, CM1 3UP, England.

Tel: +44 (0)330 088 0560

Fax: +44 (0)1245 808399

Email: sales@keison.co.uk

Please note - Product designs and specifications are subject to change without notice. The user is responsible for determining the suitability of this product.